

# RL01/RL02 Technical Manual

Volume II - Service Procedures

**digital**

# **RL01/RL02 Technical Manual**

**Volume II - Service Procedures**

Prepared by Educational Services  
of  
Digital Equipment Corporation

1st EDITION, AUGUST 1982

Copyright © 1982 by Digital Equipment Corporation

All Rights Reserved

The material in this manual is for informational purposes and is subject to change without notice.

Digital Equipment Corporation assumes no responsibility for any errors which may appear in this manual.

Printed in U.S.A.

This document was set on DIGITAL's DECset-8000 computerized typesetting system.

• **Class A Computing Devices:**

**Notice:** This equipment generates, uses, and may emit radio frequency energy. The equipment has been type tested and found to comply with the limits for a Class A computing device pursuant to Subpart J of Part 15 of FCC Rules, which are designed to provide reasonable protection against such radio frequency interference when operated in a commercial environment. Operation of this equipment in a residential area may cause interference in which case the user at his own expense may be required to take measures to correct the interference.

The following are trademarks of Digital Equipment Corporation, Maynard, Massachusetts:

DEC	DECnet	OMNIBUS
DECUS	DECsystem-10	OS/8
DIGITAL	DECSYSTEM-20	PDT
Digital Logo	DECwriter	RSTS
PDP	DIBOL	RSX
UNIBUS	EduSystem	VMS
VAX	IAS	VT
	MASSBUS	

## CONTENTS

	Page
<b>CHAPTER 1 INTRODUCTION</b>	
1.1 MAINTAINABILITY FEATURES .....	1-1
1.1.1 Hardware Maintenance Plan .....	1-1
1.1.2 Additional Documentation .....	1-1
1.1.3 Field Replaceable Units .....	1-1
1.1.4 Recommended Spare Parts List .....	1-4
1.2 SOFTWARE RESOURCES .....	1-5
1.2.1 Diagnostics .....	1-5
1.2.2 Diagnostic Supervisor .....	1-5
1.2.2.1 Hardcore Questions .....	1-5
1.2.2.2 Console Controls .....	1-8
1.2.2.3 Hardware Questions .....	1-8
1.2.2.4 Software Question .....	1-8
1.3 MAINTENANCE CONTROLS AND INDICATORS .....	1-8
1.3.1 Power ON/OFF Circuit Breaker .....	1-8
1.3.2 Power Terminal Block Assembly .....	1-8
1.3.3 Run/Stop Switch with LOAD Indicator .....	1-10
1.3.4 Unit Select (0, 1, 2, 3) Switch with READY Indicator .....	1-11
1.3.5 FAULT Indicator .....	1-11
1.3.6 WRITE PROTECT Switch and Indicator .....	1-11
<b>CHAPTER 2 REMOVAL AND REPLACEMENT PROCEDURES</b>	
2.1 INTRODUCTION .....	2-1
2.2 FRONT BEZEL AREA .....	2-1
2.2.1 Front Bezel .....	2-1
2.2.2 Prefilter .....	2-3
2.2.3 Absolute Filter .....	2-4
2.2.4 Front Panel Board .....	2-6
2.2.5 Slides .....	2-8
2.3 ACCESS COVERS .....	2-8
2.3.1 Field Service Access Cover .....	2-8
2.3.2 Cartridge Access Cover .....	2-11
2.4 BRUSH AREA .....	2-12
2.4.1 Brush Drive .....	2-12
2.4.2 Brush Tips .....	2-15
2.5 MODULES .....	2-17
2.5.1 AC Servo Module .....	2-17
2.5.2 DC Servo Module .....	2-17
2.5.3 Drive Logic Module .....	2-19

**CHAPTER 2 REMOVAL AND REPLACEMENT PROCEDURES (CONT)**

2.5.4	Read/Write Module .....	2-20
2.6	SPINDLE AREA .....	2-25
2.6.1	Belt From Spindle Pulley .....	2-25
2.6.2	Spindle Ground Button .....	2-25
2.6.3	Spindle .....	2-28
2.6.4	Sector Transducer .....	2-28
2.7	POSITIONER AREA .....	2-30
2.7.1	Positioner .....	2-30
2.7.1.1	Positioner in Early RL01 .....	2-30
2.7.1.2	Positioner in Newer RL01 and Any RL02 .....	2-32
2.7.1.3	New Head Cable Guide in Older RL01 .....	2-34
2.7.2	Read/Write Heads .....	2-36
2.8	REAR PANEL AREA .....	2-38
2.8.1	Power Supply .....	2-38
2.8.2	Spindle Drive Belt .....	2-41
2.8.3	Power Supply Fan .....	2-43
2.8.4	Circuit Breaker .....	2-44
2.8.5	Spindle Drive Motor .....	2-45

**CHAPTER 3 CHECKS, ADJUSTMENTS AND ALIGNMENTS**

3.1	INTRODUCTION .....	3-1
3.2	VOLTAGE CHECKS .....	3-4
3.3	SECTOR TRANSDUCER OUTPUT CHECK .....	3-4
3.4	SECTOR PULSE TIMING CHECK .....	3-5
3.5	READ SIGNAL AMPLITUDE ADJUSTMENT .....	3-6
3.6	POSITIONER RADIAL ALIGNMENT .....	3-10
3.7	HEAD ALIGNMENT .....	3-14
3.8	SPINDLE RUNOUT CHECK .....	3-17
3.9	POSITION SIGNAL GAIN CHECK .....	3-18
3.10	TACHOMETER AC NOISE PICK-UP CHECK .....	3-20
3.11	VELOCITY PROFILE CHECK .....	3-21
3.12	SERVO DRIVE MOTOR CURRENT CHECK .....	3-23
3.13	ACCESS TIME CHECK .....	3-24

**APPENDIX A REGISTER SUMMARY**

A.1	PROGRAM ACCESSIBLE REGISTERS FOR 11-FAMILY CONTROLLERS ...	A-1
A.1.1	Register Description .....	A-2
A.1.2	CSR Error Code Definitions .....	A-8
A.1.2.1	Operation Incomplete (OPI) .....	A-8
A.1.2.2	Data CRC (DCRC) or Write Check (WCE) .....	A-8
A.1.2.3	Header CRC (HCRC) .....	A-9
A.1.2.4	Data Late (DLT) .....	A-9
A.1.2.5	Header Not Found (HNF) .....	A-9
A.1.2.6	Non-Existant Memory (NXM) .....	A-9
A.1.2.7	Memory Parity Error (MPE) .....	A-9
A.1.3	Command Function Code Descriptions .....	A-9
A.1.3.1	Write Check - Function Code 1 .....	A-9

**APPENDIX A REGISTER SUMMARY (CONT)**

A.1.3.2	Get Status - Function Code 2 .....	A-10
A.1.3.3	Seek - Function Code 3 .....	A-10
A.1.3.4	Read Header - Function Code 4 .....	A-10
A.1.3.5	Write Data - Function Code 5 .....	A-10
A.1.3.6	Read Data - Function Code 6 .....	A-10
A.1.3.7	Read Data Without Header Check - Function Code 7 .....	A-11

**APPENDIX B INSTALLATION**

B.1	SITE PREPARATION AND PLANNING .....	B-1
B.1.1	Environmental Considerations .....	B-1
B.1.1.1	Cleanliness .....	B-1
B.1.1.2	Space Requirements .....	B-1
B.1.1.3	Floor Loading .....	B-1
B.1.1.4	Heat Dissipation .....	B-1
B.1.1.5	Acoustics .....	B-2
B.1.1.6	Temperature .....	B-2
B.1.1.7	Relative Humidity .....	B-2
B.1.1.8	Altitude .....	B-2
B.1.1.9	Power and Safety Precautions .....	B-2
B.1.1.10	Radiated Emissions .....	B-2
B.1.1.11	Attitude/Mechanical Shock .....	B-3
B.1.2	Options .....	B-3
B.1.3	AC Power Requirements .....	B-5
B.1.3.1	Standard Applications .....	B-5
B.1.3.2	Optional Applications .....	B-5
B.1.4	Grounding Requirements .....	B-7
B.1.5	Installation Constraints .....	B-8
B.2	AC CABLING .....	B-8
B.3	INSTALLATION - GENERAL .....	B-12
B.4	RL11 CONTROLLER INSTALLATION .....	B-12
B.5	RLVIII CONTROLLER INSTALLATION .....	B-17
B.5.1	Bus Interface Module .....	B-17
B.5.2	Drive Module .....	B-20
B.5.3	Module Slot Location .....	B-20
B.5.4	Module Installation .....	B-21
B.6	RLV12 CONTROLLER INSTALLATION .....	B-22
B.6.1	Introduction .....	B-22
B.6.2	Device Address Selection .....	B-22
B.6.3	Bus Selection .....	B-26
B.6.4	Interrupt Vector .....	B-26
B.6.5	Interrupt Request Level .....	B-26
B.6.6	Memory Parity Error Abort Feature .....	B-26
B.6.7	Other Jumpers .....	B-27
B.6.8	Installation .....	B-27
B.6.9	Acceptance Testing .....	B-28
B.7	RL8A CONTROLLER INSTALLATION .....	B-28
B.7.1	Introduction .....	B-28

**APPENDIX B INSTALLATION (CONT)**

B.7.2	Module Slot Location .....	B-28
B.7.3	Module Installation .....	B-28
B.8	RL01/RL02 DISK DRIVE INSTALLATION .....	B-30
B.8.1	Unpacking and Inspection .....	B-30
B.8.2	RL01/RL02 Disk Drive Unit Mounting .....	B-31
B.8.3	Drive Prestart-up Inspection .....	B-37
B.8.4	Drive Start-up Operation Check .....	B-39
B.9	CONFIDENCE TESTING .....	B-39
B.9.1	RL11-Based Diagnostics .....	B-40
B.9.2	RLV11/RLV12-Based Diagnostics .....	B-42
B.9.3	RL8A-Based Diagnostics .....	B-43
B.10	USE OF THE M9312 BOOTSTRAP WITH AN RL11 SUBSYSTEM .....	B-44

**APPENDIX C TOGGLE-IN PROGRAMS**

C.1	HEAD SELECTION PROGRAM FOR RL11/RLV11/RLV12 .....	C-1
C.2	HEAD SELECTION PROGRAM FOR RL8A .....	C-2
C.3	GET STATUS (WITH OR WITHOUT RESET) ON AN RL11/RLV11/RLV12 SUBSYSTEM .....	C-3
C.4	GET STATUS ON AN RL8A SUBSYSTEM .....	C-4
C.5	OSCILLATING SEEK FOR RL11/RLV11/RLV12 .....	C-5
C.6	OSCILLATING SEEK FOR RL8A .....	C-6

**APPENDIX D RL11 CONFIGURATION AND INSTALLATION CONSIDERATIONS**

D.1	SPC CONSIDERATIONS .....	D-1
D.2	CONFIGURATION CONSIDERATIONS .....	D-2

**FIGURES**

1-1	RL01/RL02 Disk Drive Controls and Indicators (Front Panel) .....	1-9
1-2	RL01/RL02 Disk Drive Controls and Indicators (Rear Panel) .....	1-10
2-1	Removal and Replacement Sequence Flowchart .....	2-2
2-2	Front Bezel .....	2-3
2-3	Absolute Filter Access .....	2-4
2-4	Absolute Filter .....	2-5
2-5	Front Panel Printed Circuit Board .....	2-7
2-6	Slide Rails .....	2-9
2-7	Field Service Access Cover .....	2-10
2-8	Module Location .....	2-11
2-9	DC Servo Module .....	2-13
2-10	Exposed Drive Baseplate .....	2-14
2-11	Exposed Brush Drive Assembly .....	2-16
2-12	AC Servo Module .....	2-18
2-13	Drive Logic Module W 1 Location .....	2-19
2-14a	Read/Write Module (Upright) Old Style .....	2-21
2-14b	Read/Write Module (Upright) New Style .....	2-22

## FIGURES (CONT)

2-15	Read/Write Module Box Disassembly .....	2-24
2-16	Spindle Access Cover .....	2-26
2-17	Spindle Ground Button .....	2-27
2-18	Sector Transducer Mounting .....	2-29
2-19	Positioner Assembly .....	2-31
2-20	Head Cable Guide .....	2-33
2-21	Location of Plastic Insulating Sticker .....	2-35
2-22	Read/Write Heads .....	2-37
2-23	Rear View of Drive .....	2-39
2-24	Rear Panel Assembly .....	2-40
2-25	Drive Motor Mounting .....	2-42
2-26	Drive Belt Tension .....	2-43
2-27	Circuit Breaker .....	2-44
2-28	Drive Motor Assembly Technique .....	2-45
3-1	Drive Logic Module Layout .....	3--1
3-2	Sector Transducer Output .....	3-5
3-3	Sector Pulse Timing .....	3-6
3-4	Positioner and Read/Write Module Box Assembly .....	3-7
3-5	Servo Bursts and Sector Pulse .....	3-8
3-6	Amplitude Adjustments POT Locations .....	3-9
3-7	Positioner Assembly .....	3-13
3-8	Position Signal .....	3-18
3-9	Position Signal Gain Check Waveforms .....	3-19
3-10	Summing Amplifier Output .....	3-21
3-11	Tachometer Output Velocity Signal .....	3-22
3-12	Positioner Motor Current Check .....	3-24
3-13	Access Time Check (One Track Seek) .....	3-25
3-14	Access Time Check (85 Track Seek) .....	3-25
3-15	Access Time Check (255 Track Seek) .....	3-26
B-1	RL01/RL02 Disk Drive — Rear View .....	B-5
B-2	Approved Electrical Plugs and Receptacles .....	B-6
B-3	Power Panel Grounded to Building Frame .....	B-7
B-4	Power Panel Grounded to Metal Plate .....	B-8
B-5	Typical 60 Hz Power System .....	B-9
B-6	Typical 50 Hz Power System .....	B-11
B-7	Split Phase (2-Phase) Power System .....	B-10
B-8	Three Phase Y Power System .....	B-10
B-9	RL11 Component Layout .....	B-12
B-10	RL11 Base and Vector Address Jumper Configurations .....	B-14
B-11	RL11 Priority Jumper Assembly Connections .....	B-15
B-12	RL11 Controller Installation .....	B-16
B-13	RLV11 Bus Interface Module (M8014) (Component Side) .....	B-18
B-14	RLV11 Base Address Switch Settings .....	B-19
B-15	RLV11 Vector Address Switch Settings .....	B-19
B-16	RLV11 Drive Module (M8013) .....	B-20
B-17	H9273 Backplane Grant Priority Structure .....	B-21
B-18	RLV12 Jumper Locations .....	B-24
B-19	RLV12 Device Address Format .....	B-25
B-20	RLV12 Format Interrupt Vector .....	B-26



## FIGURES (CONT)

B-21	RL8A Jumpers .....	B-29
B-22	H950 Shipping Package .....	B-30
B-23a	RL01/RL02 Cabinet Installation .....	B-32
B-23b	RL01/RL02 Cabinet Installation .....	B-33
B-24	RL01/RL02 Disk Drive - Exposed Drive Logic Module .....	B-34
B-25	RL01/RL02 - Covers Removed .....	B-35
B-26	RL01/RL02 Disk Drive - Rear View .....	B-36
B-27	RL01/RL02 Disk Drive - Front View .....	B-37

## TABLES

1-1	RL01/RL02 .....	1-2
1-2	FRU Part Numbers and Interchangeability .....	1-2
1-3	Recommended Spare Parts List .....	1-4
1-4	Diagnostic Supervisor Commands .....	1-6
1-5	Command Parameters .....	1-7
3-1	Service Jumpers for Drive Logic Module .....	3-3
3-2	Methods for Selecting Heads .....	3-3
A-1	Subsystem Registers Overview .....	A-1
A-2	Control Status Register Bit Description .....	A-2
A-3	Bus Address Register Bit Description .....	A-4
A-4	Disk Address Register Bit Description for Seek Commands .....	A-4
A-5	Disk Address Register Bit Description for Data Transfer Commands .....	A-5
A-6	Disk Address Register Bit Description for Get Status Commands .....	A-5
A-7	MP Register Bit Description for Get Status Commands .....	A-5
A-8	MP Register Bit Description for Read Header Commands .....	A-7
A-9	MP Register Bit Description for Data Transfer Commands .....	A-8
A-10	RL8A Instruction Set .....	A-11
A-11	Command Register A During a Seek Command .....	A-12
A-12	Command Register A During Read or Write Data Command .....	A-13
A-13	Command Register B .....	A-14
A-14	Break Memory Address Register .....	A-15
A-15	Word Count Register .....	A-15
A-16	Sector Address Register .....	A-15
A-17	Error Register .....	A-16
A-18	Silo Buffer Word 1 of a Get Status Command .....	A-17
A-19	Silo Buffer Word 2 of a Get Status Command .....	A-18
A-20	Silo Data Buffer Contents Following a Read Header Command .....	A-19
B-1	Saleable RL01/RL02 Subsystem Options .....	B-3
B-2	Saleable Cabinet Options: (Includes Skins, Doors, Covers, Trim, and Power Controllers) .....	B-4
B-3	Address Selection .....	B-23
B-4	Diagnostic Catalogs and Indexes .....	B-40
B-5	RL11 Based Diagnostics .....	B-40
B-6	RL11 Diagnostic Kit Numbers .....	B-40

**TABLES (CONT)**

B-6	RL11 Diagnostic Components .....	B-41
B-8	User Documents .....	B-42
B-9	RLV11/RLV12 Diagnostic Kit Designations .....	B-42
B-10	RL8/RL01 Diagnostic Components .....	B-43
B-11	RL8/RL01 Diagnostic Kits .....	B-44
B-12	RL8A Diagnostic Kits .....	B-44
B-13	RL8/RL02 Diagnostic Components .....	B-45

# CHAPTER 1

## INTRODUCTION

This chapter defines the maintenance philosophy and acquaints the reader with the structure of this portion of the manual. It defines the required resources available to correctly maintain the RL01/RL02 disk subsystem. The maintenance controls and indicators are also discussed here.

### 1.1 MAINTAINABILITY FEATURES

The following paragraphs summarize the RL01 and RL02 hardware maintenance plans. The manual organization is outlined and an overview of the various troubleshooting techniques is discussed. A listing of Field Replaceable Units (FRUs) is also given.

#### 1.1.1 Hardware Maintenance Plan

Serviceability has been a major consideration in the design of the RL01/RL02 disk subsystem. A large portion of the drive electronics has been incorporated on one logic module, the drive logic board. The remaining electronics exist on the read/write module, dc servo module, ac servo module, and the front panel.

The removal/replacement capability is accomplished without the aid of special alignment fixtures or tools. These designed-in features readily permit a maintenance philosophy of module or subassembly replacement. Therefore, the troubleshooting strategy is to isolate the failing module or subassembly and replace it.

#### 1.1.2 Additional Documentation

Table 1-1 lists the hardware documentation that is available to support the RL01/02 Disk Subsystem.

#### 1.1.3 Field Replaceable Units

Table 1-2 is a list of RL01/RL02 Field Replaceable Units (FRUs). Some of the FRUs contain components that are easily checked and replaced. In these cases, an FRU may be repaired instead of replaced. For example, a lamp may be replaced on the front panel or a pico fuse replaced on the DC Servo module. The decision to replace or repair an FRU should be based on such local considerations as part availability, etc.

Some of the FRUs are interchangeable between the RL01 and RL02 and some are not. The interchangeability is indicated in Table 1-2.

**Table 1-1 RL01/02 Documentation**

<b>Name</b>	<b>Microfiche Number</b>	<b>Hard Copy Number</b>
RL11 Controller Technical Description Manual	EP-ORL11-TD	EK-ORL11-TD
RLV11 Controller Technical Manual	EP-RLV11-TD	EK-RLV11-TD
RL8A Omnibus Controller Technical Manual	EP-ORL8A-TM	EK-ORL8A-TM
RL01 Disk Drive Illustrated Parts Breakdown	EP-00016-IP	EK-ORL01-IP
RL02 Disk Drive Illustrated Parts Breakdown	EP-00016-IP	EK-ORL02-IP
RL01/RL02 Preventive Maintenance Procedures	EP-00008-PM	EK-RL012-PM
RL01/RL02 Pocket Service Guide	N/A	EK-RLTER-PS
RL01/RL02 Disk Subsystem User's Guide	N/A	EK-RL012-UG
RLV12 Disk Controller User's Guide	N/A	EK-RLV12-UG
RLV12 Controller Technical Description Manual	EP-RLV12-TD	EK-RLV12-TD

**Table 1-2 FRU Part Numbers and Interchangeability**

<b>FRU</b>	<b>RL01 Part Number</b>	<b>RL02 Part Number</b>
Read/Write Module	54-11844	54-13536
DC Servo Module	54-11850	54-13534
Template for DC Servo	74-18588	74-20826
Drive Logic Module (DLM)	54-12175 (early)	54-13531 (early)
	54-12175 Rev K①	54-14025 (later)
		54-14025 Rev L①

**Table 1-2 FRU Part Numbers and Interchangeability (Cont)**

FRU	RL01/02 Part Number	
Spindle	70-15116	
5 amp fuse (DC Servo)	12-05747-00	
AC Servo Module	54-11848	
Front Panel	54-11846	
Front Panel Lamp (GE 73)	12-12716-01	
Sector Transducer	70-12137	
Positioner	70-12117	
Brush Drive Assembly	70-12112	
Brush Assembly	70-16726	
Spindle/Blower Motor	70-12114	
Spindle Drive Belt	12-13369	
Spindle Ground Brush	74-15294	
Coarse Filter	74-15297	
Absolute Filter	12-13097-00	
I/O Terminator	70-12293-00	
Cartridge Access Cover Roller Guides	74-21977	
Cover Switch Assembly 1	70-16991	
Head Cable Guide	70-16983	
Insulating Sticker	74-22834	
Power Panel	70-12130	
• Cooling fan	12-09403-01	
• Transition Connector	12-11591-35	
<b>FRU</b>	<b>RL01 Part Number</b>	<b>RL02 Part Number</b>
Upper Head	74-17178-01	70-15637-01
Lower Head	74-17178-00	70-15637-00

**NOTE**

All part numbers denoted with a ① represents those FRUs that must be used in RL01s or RL02s that do not have cleaning brushes.

### 1.1.4 Recommended Spare Parts List

Table 1-3 shows the Recommended Spare Parts List.

**Table 1-3 Recommended Spare Parts List**

<b>Part Number</b>	<b>Description</b>	<b>Branch Stocked</b>	<b>Spare Kit</b>
70-12130	Power Panel	Y	N
54-11844	Read/Write Module (RL01 only)	Y	Y
54-12526	Read/Write Module (RL01, RL02)	Y	Y
54-11846	Front Panel Board	Y	Y
54-11848	AC Servo Module	Y	Y
54-11850	DC Servo Module (RL01 only)	Y	Y
54-13534	DC Servo Module (RL01, RL02)	Y	Y
54-12175	Drive Logic Module (RL01 only)	Y	Y
54-14025	Drive Logic Module (RL01, RL02)	Y	Y
70-12107	Front Panel Cable	N	N
70-12108	Harness Power Panel	N	N
70-12109	Line Cable	Y	N
70-12110	Cooling Fan Cable	N	N
70-12112	Brush Drive Assembly	Y	Y
70-12114	Disk Motor Assembly	Y	N
70-12117	Positioner Assembly	Y	N
70-12119	Rear Cover	N	N
70-12120	Spindle Assembly (RL01 only)	Y	N
70-15116	Spindle Assembly (RL01, RL02)	Y	N
70-16991	Cover Switch Assembly (RL01, RL02, DRIVES without brushes)	Y	N
70-12123	Cable Logic	N	N
70-12126	Brush/Door Harness	N	N
70-16852-01A	Terminal Block Assembly	Y	N
70-12136	Positioner Harness	N	N
70-12137	Transducer Assembly	Y	Y

**Table 1-3 Recommended Spare Parts List (Cont)**

<b>Part Number</b>	<b>Description</b>	<b>Branch Stocked</b>	<b>Spare Kit</b>
70-12139-01	Read/Write Cable	N	N
70-12139-02	AC Servo Cable	N	N
70-12140	DC Power Harness	N	N
70-12142	Power Harness	N	N
12-13369	Drive Belt	Y	Y
74-15297	Prefilter	Y	N
12-13097-03	Absolute Filter	Y	N
74-17178-00	Head "A" Up (RL01)	Y	Y
74-17178-01	Head "A" Down (RL01)	Y	Y
70-15637	Head "A" Up (RL02)	Y	Y
70-15638	Head "A" Down (RL02)	Y	Y
RL01K-DC	Cartridge (RL01)	Y	N
RL02K-DC	Cartridge (RL02)	Y	N
70-12293	Terminator	Y	N
70-12139-0D	DC Servo Cable	N	N
74-15231	Gasket, Blower	Y	N
12-09403-01	Fan	Y	N
12-14360-02	Circuit Breaker	N	N

## 1.2 SOFTWARE RESOURCES

### 1.2.1 Diagnostics

The various diagnostics available for RL8A, RL11, RLV12, and RLV11-based subsystems are described in Appendix B, Paragraph B.9, "Confidence Testing".

### 1.2.2 Diagnostic Supervisor

All of the diagnostics are run under the Diagnostic Supervisor. When one of the diagnostics is called up, the Supervisor asks a series of questions that enables the operator to set various parameters governing the specific diagnostic. The various commands the Supervisor will accept are summarized in the following paragraphs. (Questions whose answers are self-evident are not explained here.)

**1.2.2.1 Hardcore Questions** – Several of the questions that the Supervisor will ask do not have simple yes or no answers. These include the questions explained below.

The Supervisor will display the statement "TYPE TWO CHARACTERS FOUR SECONDS APART" when no clock is on the system. The system will then subdivide the spacing for use as a clock. The four second interval should be as accurate as possible.

The prompt "DS-C>" is requesting one of eleven supervisor "commands" listed in Table 1-4.

**Table 1-4 Diagnostic Supervisor Commands**

---

<b>Command</b>	<b>Description</b>
<b>STA</b>	<b>ST</b> Art diagnostic and then produce questions for generation of the diagnostic parameter tables (“P” tables).
<b>RES</b>	<b>RE</b> Start diagnostic at the point following the hardware questions. The “P” tables set up by the STA command will be used.
<b>CON</b>	<b>CON</b> tinue the diagnostic at the beginning of the subroutine that was being executed when the diagnostic was halted by an error or control “C”.
<b>PRO</b>	<b>PRO</b> ceed testing with the diagnostic at the starting address of the subroutine following the one that caused the error report.
<b>DIS</b>	<b>DIS</b> play the hardware “P” tables for all the drives under test.
<b>DRO</b>	<b>DRO</b> p the desired units from being tested. “UNITS”, in this case, refers to the “P” table units, not necessarily the device unit numbers. The DIS command will give the operator the drive unit number.
<b>ADD</b>	<b>ADD</b> units back into the testing sequence after they had been dropped by the DRO command.
<b>PRI</b>	<b>PRI</b> nt any performance or statistical tables accumulated by the diagnostic.
<b>FLA</b>	<b>FLA</b> gs command – The current setting of all the flags set up under the STA command are printed out for inspection.
<b>ZFL</b>	<b>Zer</b> o <b>FLA</b> gs command – All current flags set by the STA command are cleared by this command.
<b>CCI</b>	<b>Cr</b> eat <b>E</b> <b>Co</b> re <b>I</b> mage command – This command enables a BIC file to be created on these diagnostics to be run under the XXDP media. (See listing for directions.)

---

**NOTE**

The last character in the prompt (in this example a “C”) reflects the revision level of the diagnostic supervisor. The example in this text is DS-C>. Diagnostic Supervisor revision “C”.

Program Parameter Changes – Type in any combination of the parameters listed in Table 1-5 to affect the indicated commands.



**Table 1-5 Command Parameters**

---

<b>Command</b>	<b>Parameter</b>
<b>STA</b>	<p>DS-C&gt;STA/TESTS: (insert test numbers desired from the test lists in the individual diagnostic listings; e.g. 1:2 means tests 1 and 2, or 1-5:8-10 means tests 1 through 5 and 8 through 10.)</p> <p>DS-C&gt;STA/TESTS:6/PASS: (insert the number of passes the diagnostic should take before halting)</p> <p>DS-C&gt;STA/TESTS:6/PASS:2/FLAGS: (insert any of these mnemonic(s) representing a program flag(s)):</p> <ul style="list-style-type: none"><li>HOE – Halt On Error</li><li>LOE – Loop On Error</li><li>IER – Inhibit Error Report</li><li>IBE – Inhibit Basic Error reporting</li><li>IXE – Inhibit eXtended Error reporting</li><li>PRI – PRInt messages on line printer</li><li>PNT – PriNt Test numbers as they are being executed</li><li>BOE – Bell On Error</li><li>UAM – Bypass manual intervention tests</li><li>ISR – Inhibit Statistical Reports</li><li>IDR – Inhibit DRopping of units</li></ul> <p>DS-C&gt;STA/TESTS:6/PASS:2/FLAGS:IER:PNT:BOE:IDR/EOP: (insert a number equaling the pass intervals at which the End Of Pass message will be printed; e.g. every other pass, every third pass, etc.)</p> <p>For example, utilizing all the possible parameter changes, the STA command would look like this:</p> <p>DS-C&gt;STA/TESTS:6/PASS:2/FLAGS:IER: PNT:BOE:IDR/EOP:3</p>
<b>RES</b>	Use TESTS, PASS, FLAGS and/or UNITS to be tested; e.g. DS-C>RES/TESTS:6/UNITS:1 (this will run only test 6 on the device specified in “P” table 1)
<b>CON</b>	Use PASS or FLAGS only
<b>PRO</b>	Use FLAGS only
<b>DRO</b>	Use UNITS only
<b>DIS</b>	Use UNITS only
<b>ADD</b>	Use UNITS only

---

**Table 1-5 Command Parameters (Cont)**

---

<b>Command</b>	<b>Parameter</b>
<b>PRI</b>	No variations
<b>FLA</b>	No variations
<b>ZFL</b>	No variations
<b>CCI</b>	Use TESTS, PASS or FLAGS

---

**1.2.2.2 Console Controls** – There are three console controls that can be used to affect a running diagnostic. They are all typed by holding down the “CONTROL” key while typing the specific letter.

Control “C” causes testing to cease and a return to the start (DS-C>).

Control “Z” causes default values to be taken in any of the three operator dialogues.

Control “O” causes a suppression of typeouts for the remainder of the diagnostic or until another control “O” is typed.

**1.2.2.3 Hardware Questions** – It is during the hardware question portion of the Supervisor that the “P” (parameter) tables are built. There is one “P” table for every unit to be tested. Also, “UNITS” pertains to the “P” table number, not the device unit number. If there is doubt as to which unit number has been assigned to which drive, the DIS command (see Table 1-4) will supply the necessary information.

**1.2.2.4 Software Question** – The question “CHANGE SW(L)?” asks if any of the software parameters are to be changed. A “Y” will cause the program to ask various questions. For more detail refer to the individual program document.

### **1.3 MAINTENANCE CONTROLS AND INDICATORS**

Figures 1-1 and 1-2 show all RL01/RL02 Disk Drive controls and indicators.

#### **1.3.1 Power ON/OFF Circuit Breaker**

When the ac power plug is inserted into a 115/230 Vac, 50/60 Hz outlet, ac power is applied to the rear panel circuit breaker on the drive. When the circuit breaker is turned on, ac power is applied to the drive and the blower motor is energized.

#### **1.3.2 Power Terminal Block Assembly**

The RL01/RL02 Disk Drive operates within two ac line voltage ranges at either 50 or 60 Hz:

- 90 – 128 Vac
- 180 – 256 Vac

These voltage ranges may be manually selected by changing the position of the terminal block assembly covers located at the rear of the drive. Refer to Figure 1-2.

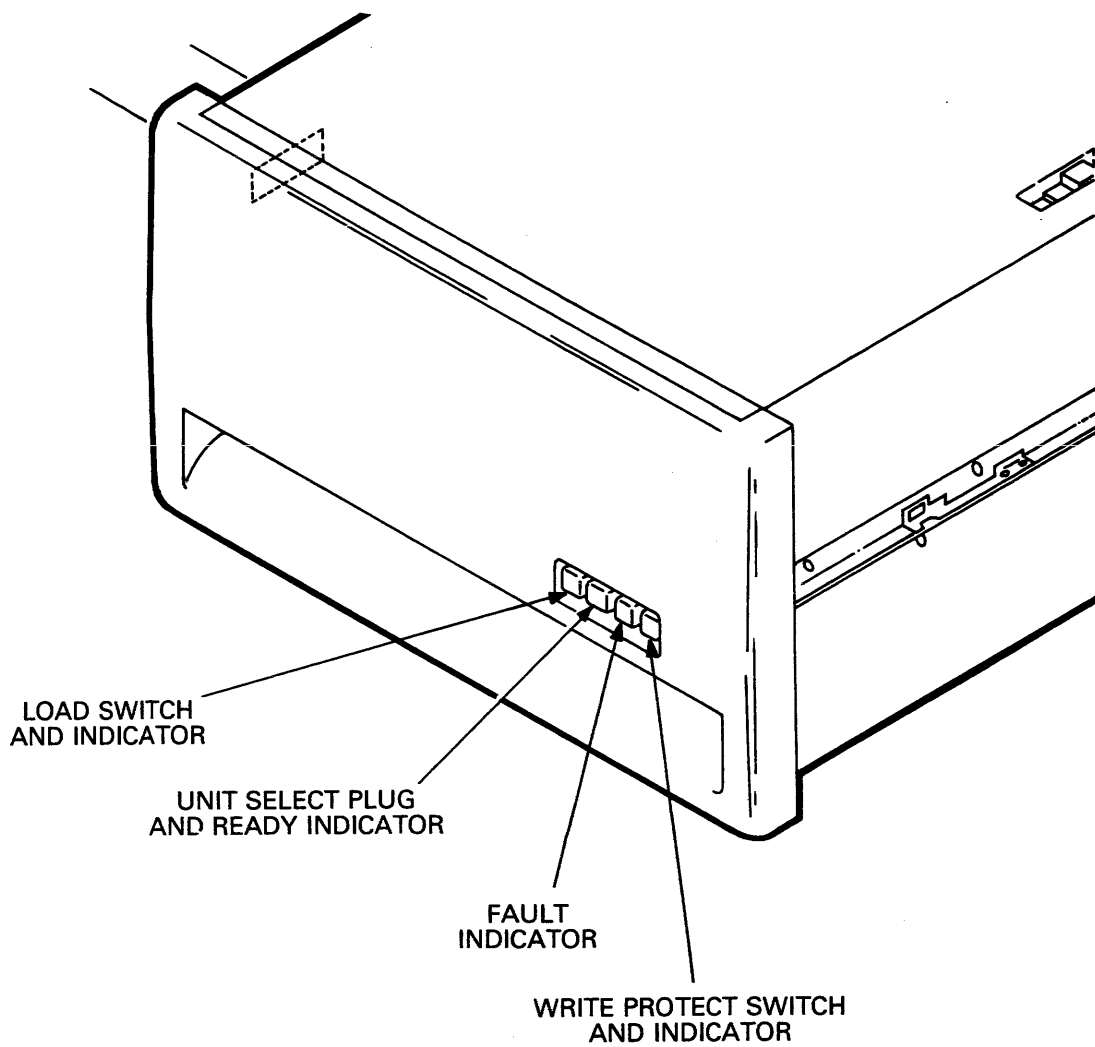

CZ-1005

Figure 1-1 RL01/RL02 Disk Drive Controls and Indicators (Front Panel)

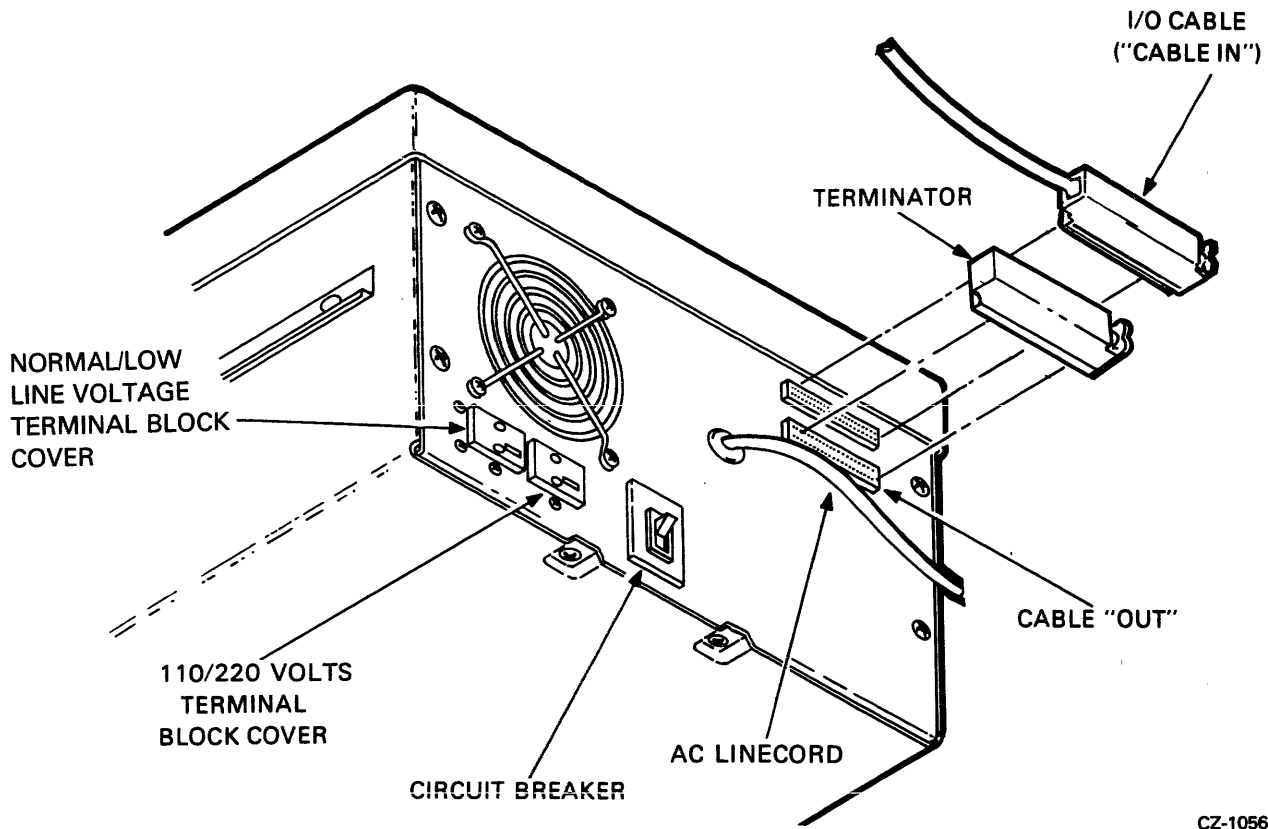

Figure 1-2 RL01/RL02 Disk Drive Controls and Indicators (Rear Panel)

### 1.3.3 Run/Stop Switch with LOAD Indicator

This push on/push off switch, when depressed, energizes the spindle motor providing all of the following conditions have been met.

- The disk cartridge has been installed
- The cartridge protective cover is in place and the cartridge access door is closed
- All ac and dc voltages are within specifications
- The read/write heads are home (retracted)
- The brushes are home (on those drives that have brushes)

When the run/stop switch is released, the spindle drive motor is de-energized if the read/write heads are not loaded. If the heads are loaded, they are immediately retracted and the spindle drive motor is then de-energized.

#### NOTE

**In the event of a Seek Time-out error (SKTO) the heads do not retract and the disk remains spinning.**

In the event of a main power interrupt and subsequent power restoration, the drive will recycle up if the switch is in the depressed state since it contains mechanical memory.

The LOAD enable indicator is illuminated whenever all of these conditions have been met.

- The spindle is stopped
- The read/write heads are home
- The brushes are home (on those drives that have brushes)

#### **1.3.4 Unit Select (0, 1, 2, 3) Switch with READY Indicator**

The unit select switch is a cam operated switch which is actuated by inserting a numbered, cammed button. The switch contacts are binary encoded so the drive interface logic recognizes the matching controller generated drive address code and the corresponding unit select number (0, 1, 2, or 3).

The numbered indicator, when lit, indicates a drive READY condition. Drive READY exists when both of the following conditions are met.

- The read/write heads are loaded
- The heads are detented on a specific track

#### **1.3.5 FAULT Indicator**

The FAULT indicator is lit whenever any of the following fault or error conditions develop in the disk drive.

- Drive select error
- Seek time out error
- Write current in heads during sector time error
- Loss of system clock
- Write protect error
- Write data error
- Spin error

#### **1.3.6 WRITE PROTECT Switch and Indicator**

When this switch is pushed in, it will lock in the depressed position and the drive will be write protected. If the drive is writing as the switch is pushed in, FAULT will light. When the switch is pushed again, releasing it from the depressed state, the drive will no longer be write protected.

## CHAPTER 2

# REMOVAL AND REPLACEMENT PROCEDURES

### 2.1 INTRODUCTION

This chapter describes the removal and replacement procedures for the various Field Replaceable Units (FRUs) in the RL01 and RL02 Disk Drives. The flow chart in Figure 2-1 illustrates the sequence of FRU removal. For example, to remove the spindle, the cartridge access cover must be removed. This is followed by the field service access cover, the spindle access cover and the belt from the spindle pulley. The FRUs are generally replaced in reverse order of removal.

The number in each oval of Figure 2-1 is the paragraph that describes the removal and replacement for that particular FRU.

Most of the removal and replacement procedures in this chapter contain references to earlier paragraphs. This drive is simple enough that the FE should not have to refer back to these other paragraphs once he has had some experience on the drive. The flow chart can serve as a quick reminder, if necessary.

### 2.2 FRONT BEZEL AREA

#### 2.2.1 Front Bezel

To remove the front bezel:

1. Turn CB1 (rear panel) off and extend drive from cabinet.
2. Locate and remove the four Phillips head screws as shown in Figure 2-2.

#### CAUTION

**When removing the last screw, hold the front bezel so that the bezel will not strain the front panel switch cable.**

3. Disconnect the front panel board cable. Note the orientation of the colored stripe on the cable.

To replace the front bezel:

1. Connect the front panel board cable.
2. Locate the top mounting holes in the front bezel and align them with the top mounting holes in the drive frame (Figure 2-2).
3. Secure the front bezel with the Phillips head screws, finger-tight only.

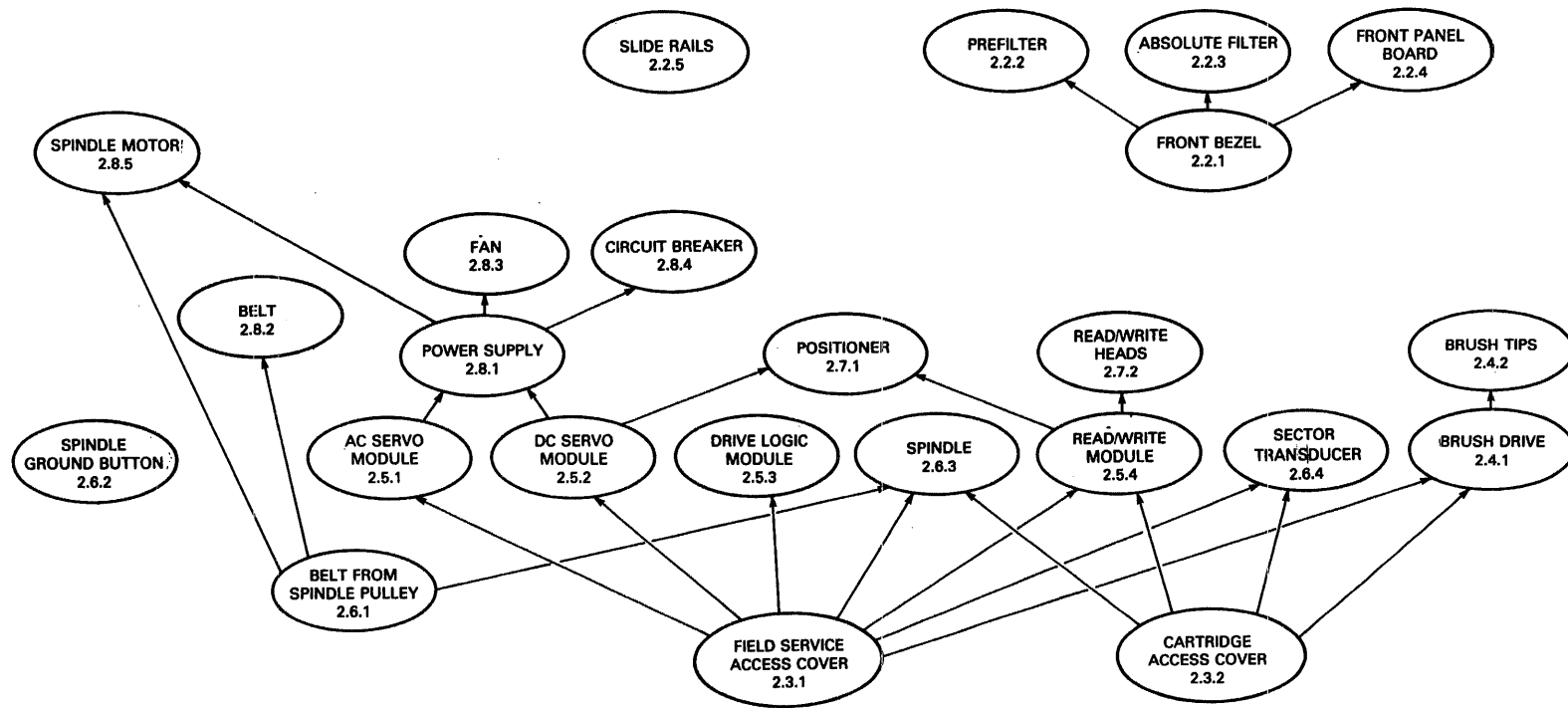
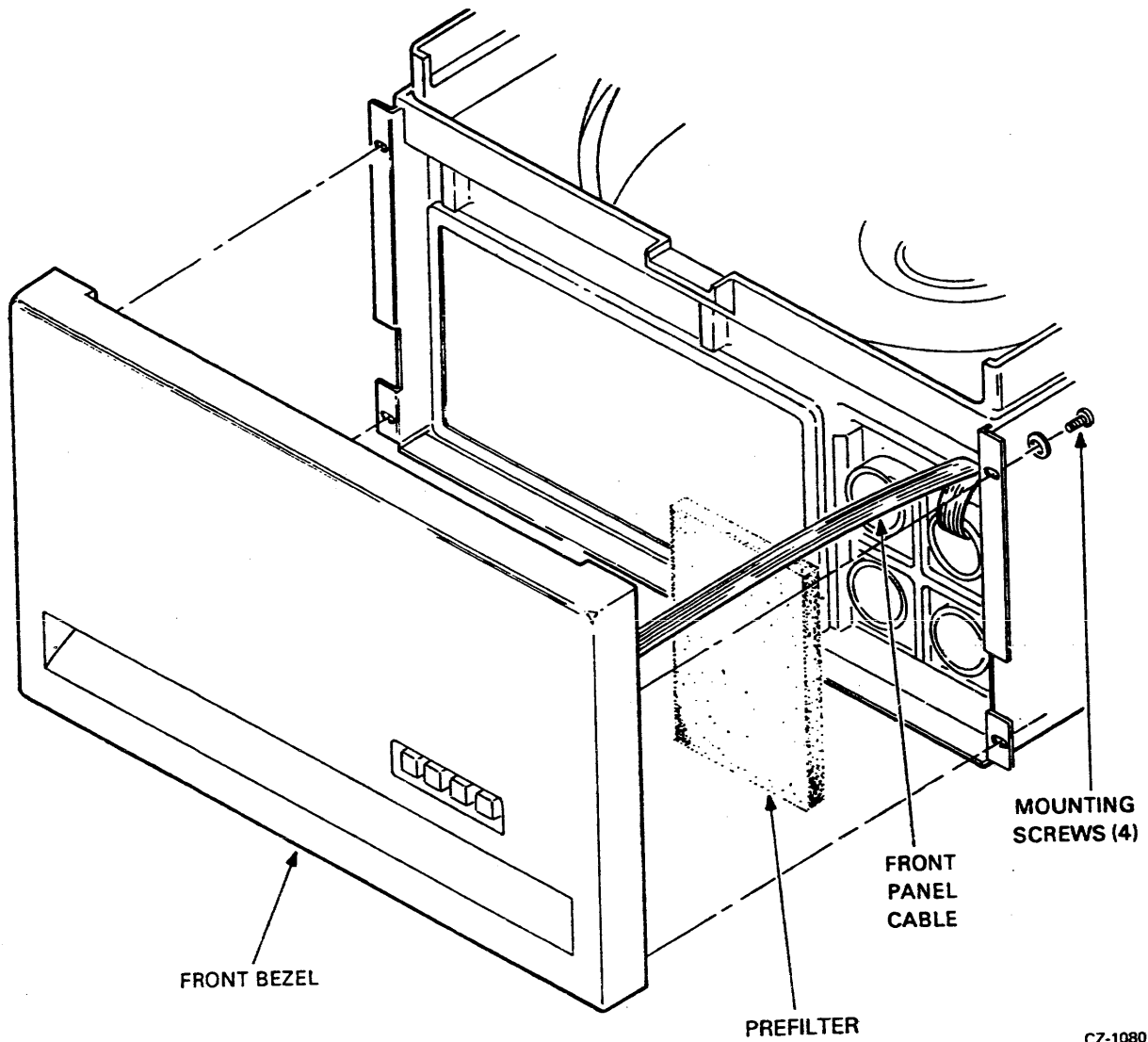

Figure 2-1 Removal and Replacement Sequence Flow Chart



CZ-1080

Figure 2-2 Front Bezel

4. Slide the drive into the cabinet and align the front bezel for correct side-to-side clearance.
5. Extend the drive from the cabinet and tighten the Phillips head screws securely.
6. Slide the drive back into the cabinet.

### 2.2.2 Prefilter

To remove the prefilter:

1. Remove the front bezel (Paragraph 2.2.1).
2. Remove the prefilter located on the right front side of the drive (Figure 2-2).



To replace the prefilter:

1. Install the prefilter in the recess located on the right front side of the drive, directly over the four air chamber tubes (Figure 2-2).
2. Replace the front bezel (Paragraph 2.2.1).

### 2.2.3 Absolute Filter

To remove the absolute filter:

1. Remove the front bezel (Paragraph 2.2.1).
2. Locate the two plenum springs and two plenum cover latches as shown in Figure 2-3.

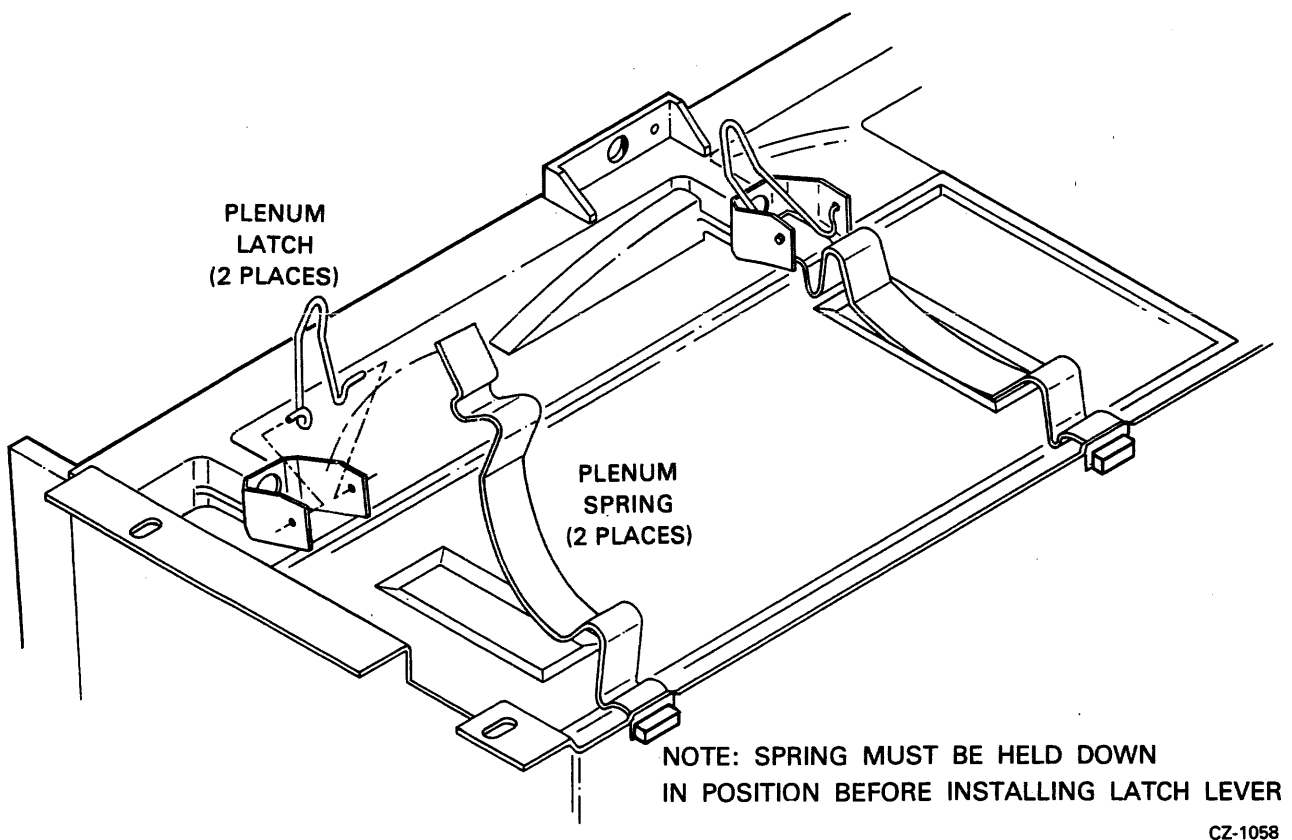

CZ-1058

Figure 2-3 Absolute Filter Access

3. Lift one of the plenum latches. While holding plenum spring, squeeze the latch and remove latch from bracket.
4. Remove plenum spring.
5. Repeat for the other plenum latch and spring.

6. The plenum cover may now be removed by pulling the cover forward. This allows access to the filter (Figure 2-4).
7. Use a screwdriver (or one of the plenum springs) to pry the left side of the filter out slightly **before** moving the right side. The filter can then be removed by rocking it from side to side until it slides free.

**NOTE**

**Never reinstall a used absolute filter.**

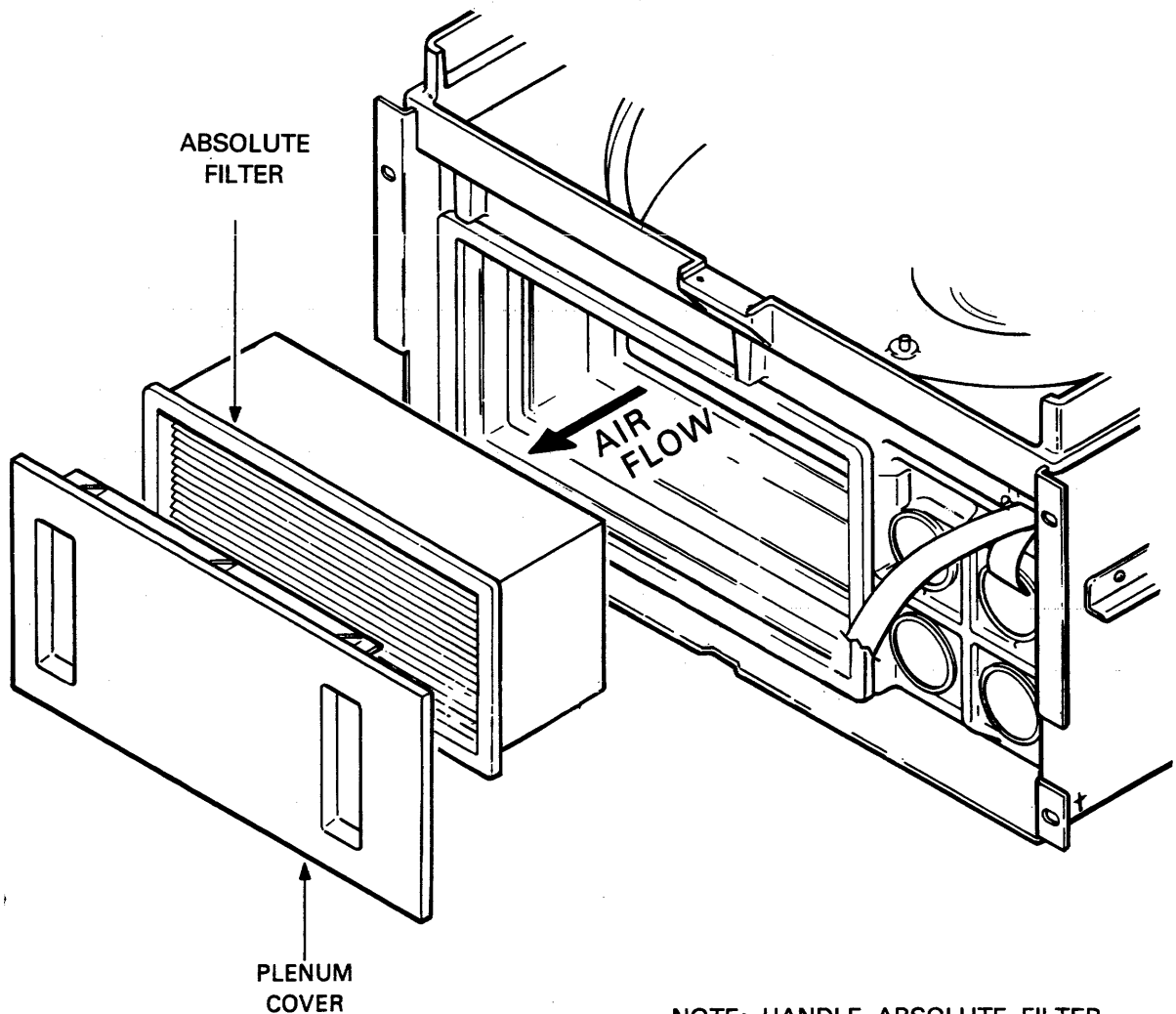

**NOTE: HANDLE ABSOLUTE FILTER  
BY ITS OUTSIDE HOUSING ONLY**

CZ-1059

Figure 2-4 Absolute Filter

To replace the absolute filter:

1. Insert a new absolute filter into the air duct cavity located on the left front side of the drive. Be sure the filter is firmly seated against its gasket. It may be necessary to use a plenum spring to pry the filter into place.
2. Place clear plastic plenum cover over the absolute filter such that the cover seats on the gasket.
3. Install a plenum spring by inserting its bottom tang into the slot provided and rotating the spring such that it fits inside the plenum spring latch bracket (Figure 2-3).
4. While pressing the plenum spring firmly against the plenum cover, insert the plenum latch by squeezing the latch and placing the latch into the holes of the plenum latch bracket. See Figure 2-3.
5. Push the plenum latch into the "locked" position.
6. Repeat the process for the other plenum spring and latch.
7. Replace the front bezel (Paragraph 2.2.1).

#### **2.2.4 Front Panel Board**

To remove the front panel board:

1. Remove the front bezel (Paragraph 2.2.1).
2. Locate the screws holding the front panel board to the front bezel (Figure 2-5) and remove them.

To replace the front panel board:

1. Secure the front panel board to the front bezel (Figure 2-5).
2. Replace the front bezel (Paragraph 2.2.1).

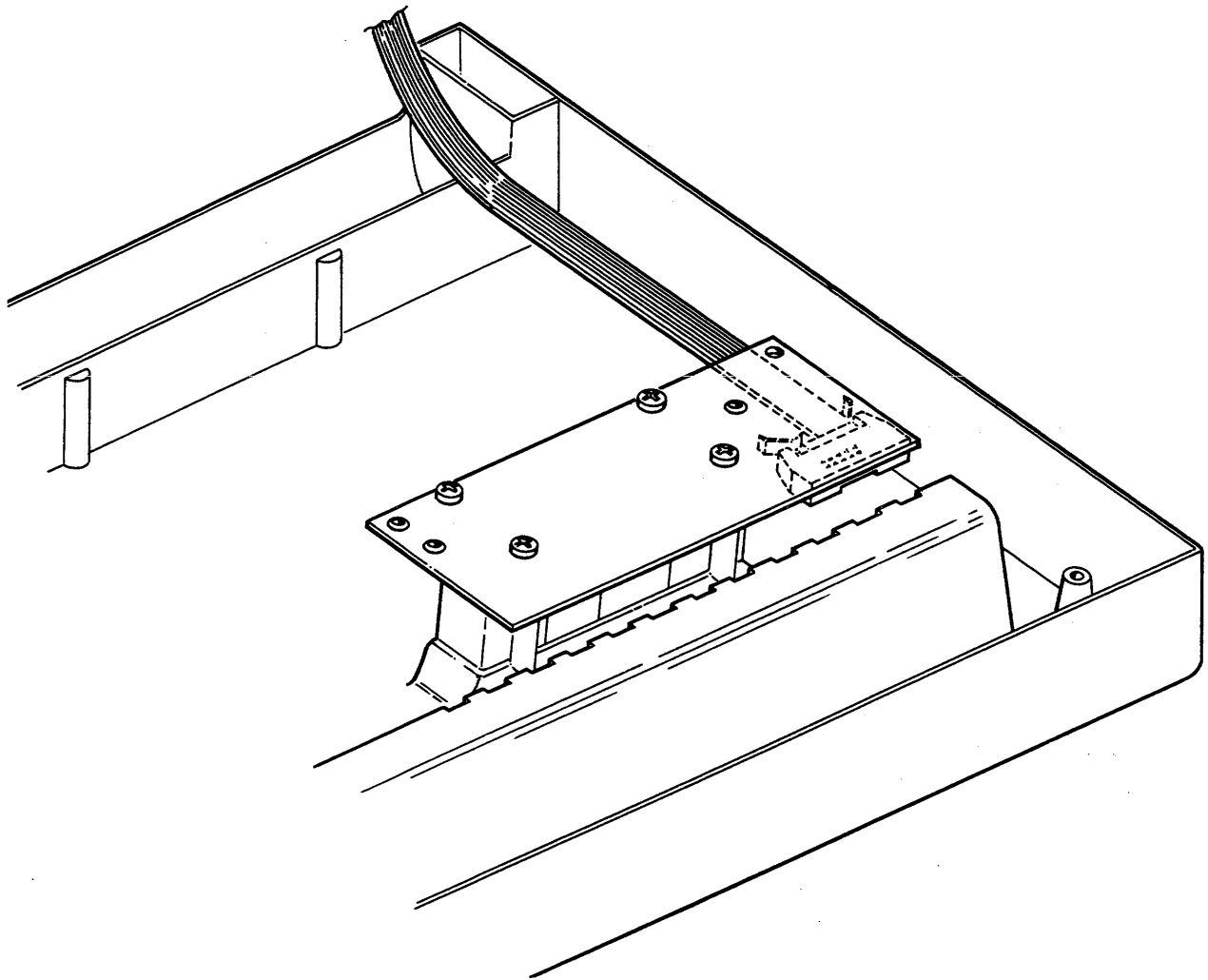

CZ-0008

Figure 2-5 Front Panel Printed Circuit Board

### **2.2.5 Slides**

To remove the drive from the slides:

1. Turn CB1 off (rear panel) and extend the drive to its second set of stops by releasing the slide extension release catches on both slides. See Figure 2-6. Remove the I/O cables and unplug the ac line cord.
2. Locate and remove the two front screws securing the drive to each slide as shown in Figure 2-6 (detail).
3. Locate the locking latch on each drive rail. (See Figure 2-6.) Actuate them by pulling each latch away from the drive and lifting at the same time to remove the drive from the slides.

#### **WARNING**

**The drive weighs 34 kg (75 lb). Use care when lifting the drive.**

To replace the drive on the slides:

1. Extend both slides fully and place the drive onto the slides. Ensure the locking latch engages the front of each side (Figure 2-6) and that the rear locking tab engages each slide rail.
2. Secure the front slide screws first, then adjust the slide position to gain access to the rear screws. See Figure 2-6.
3. Push the drive into the cabinet and reconnect the ac line cord and I/O cables. Turn CB1 back on.

## **2.3 ACCESS COVERS**

### **2.3.1 Field Service Access Cover**

To open the field service access cover:

1. Turn CB1 off (rear panel) and extend the drive from the cabinet.
2. Locate and remove the captive screws in the cover as shown in Figure 2-7.
3. Lift the cover up slightly and rotate backward. Rest the cover on the rear flange of the base-plate, using the holding bracket (Figure 2-7).

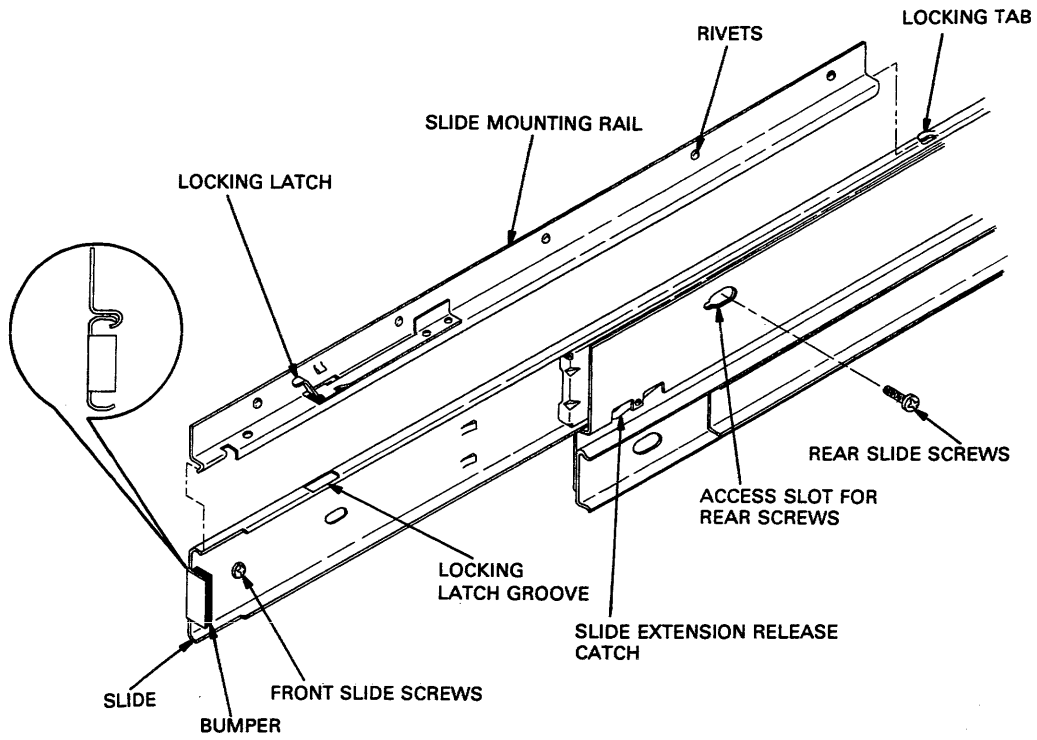

CZ-0503

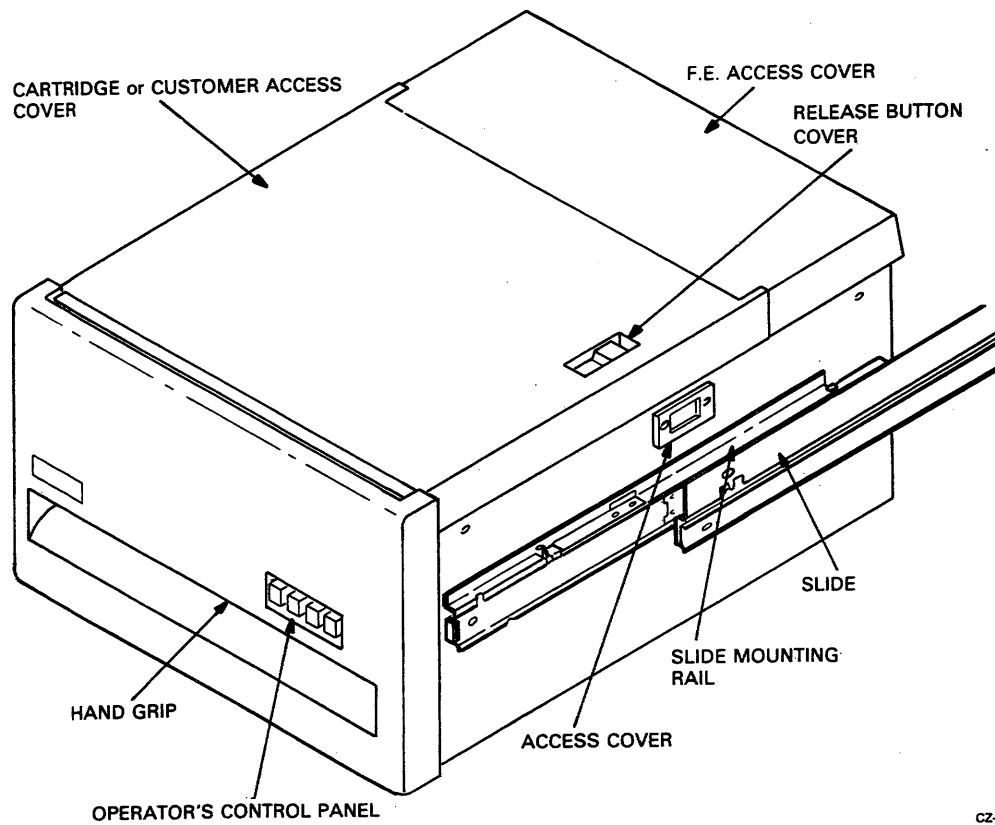

CZ-0502

Figure 2-6 Slide Rails

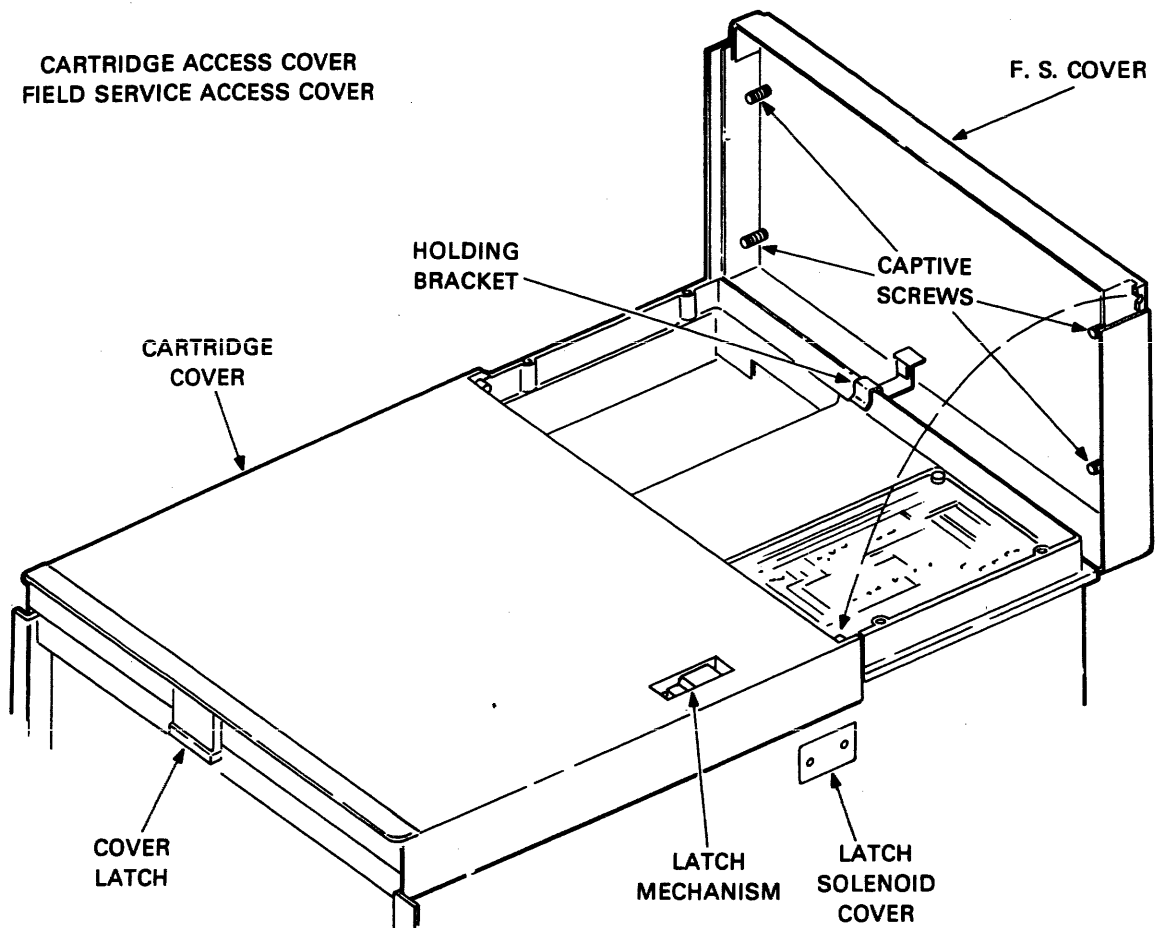

CZ-0010

Figure 2-7 Field Service Access Cover

To remove the field service access cover:

1. Remove all cables connected to the drive logic module (Figure 2-8) noting the orientation of the colored stripe on each cable.
2. Lift cover off the holding bracket and set aside.

To replace the field service access cover:

1. Place the cover on the rear flange of the baseplate (Figure 2-7).
2. Reconnect all cables to the drive logic module.

3. Lift the cover slightly, rotate it forward and place it into position. The cartridge access cover is held in place by the front edge of the field service access cover.
4. Tighten the captive screws.
5. Turn CB1 on and slide the drive back into the cabinet.

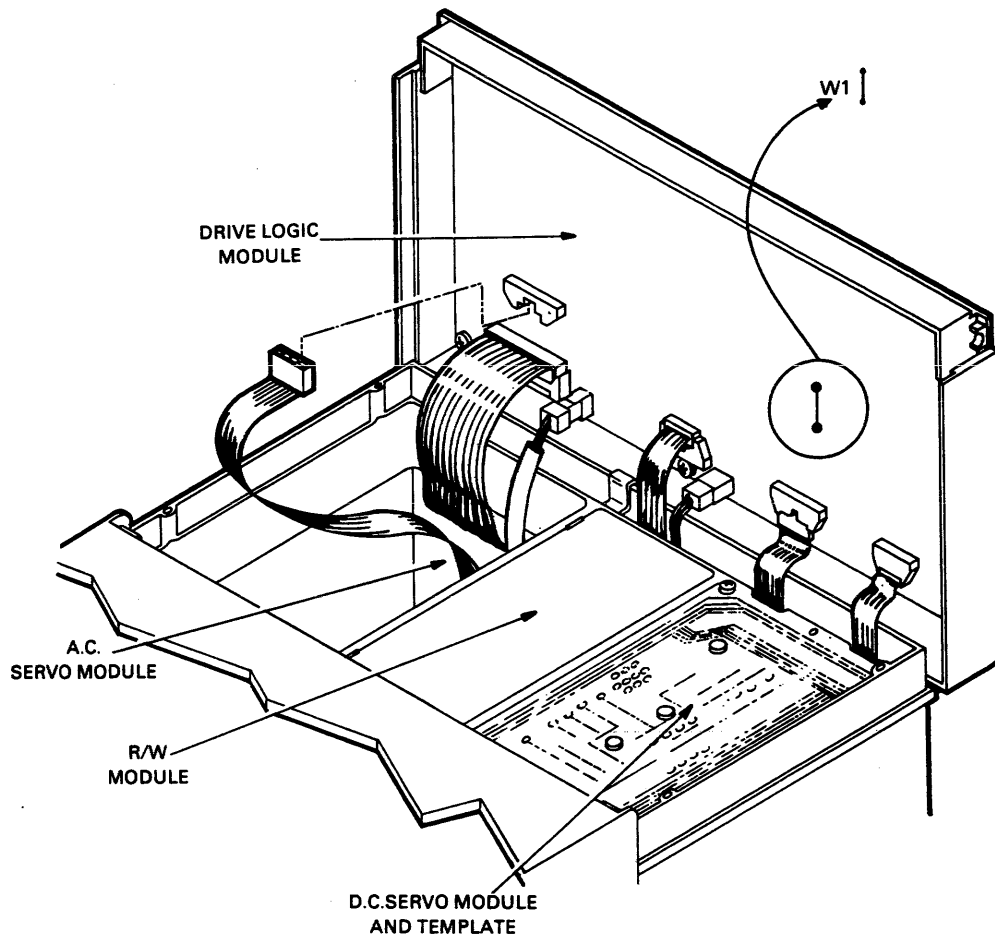

CZ-0011

Figure 2-8 Module Location

### 2.3.2 Cartridge Access Cover

To remove the cartridge access cover:

1. Open the field service access cover (paragraph 2.3.1).
2. Lift the rear part of the cartridge access cover (Figure 2-7) approximately two inches.
3. Push backwards on the cover latch mechanism. The cover will pop up in front.
4. Lift cover straight up off the baseplate. The spring-loaded cover arms will snap to the rearward position.



To replace the cartridge access cover:

1. Pull the spring-loaded cover arms forward so that they are parallel to the cover.
2. Guide the cover arms in the rollers provided on the casting.
3. Position the cover over the drive baseplate and lower the front edge until it engages the latch at the top front lip of the drive baseplate.
4. Lower rear edge to the baseplate.
5. Close the field service access cover (Paragraph 2.3.1).

## **2.4 BRUSH AREA**

### **2.4.1 Brush Drive**

To remove the brush drive:

1. Remove the field service access cover (Paragraph 2.3.1).
2. Remove the cartridge access cover (Paragraph 2.3.2).
3. Locate the dc servo module (see Figure 2-8 for location).
4. Remove the four screws securing the plastic template and module to the baseplate.
5. Lift the module straight up and place it in the baseplate slots (Figure 2-9).
6. Locate the brush motor assembly (see Figure 2-10) and remove the Phillips head screws located at the three corners of the assembly.
7. Detach the brush motor drive cable connector (Figure 2-9).
8. Lift the brush motor assembly straight up.

To replace the brush drive:

1. Place the brush motor assembly over its mounting surface and plug in the keyed cable connector.
2. Insert the brush motor assembly into cavity and secure with three Phillips head screws.
3. Replace the dc servo module.
4. Replace the cartridge access cover (Paragraph 2.3.2).
5. Replace the field service access cover (Paragraph 2.3.1).

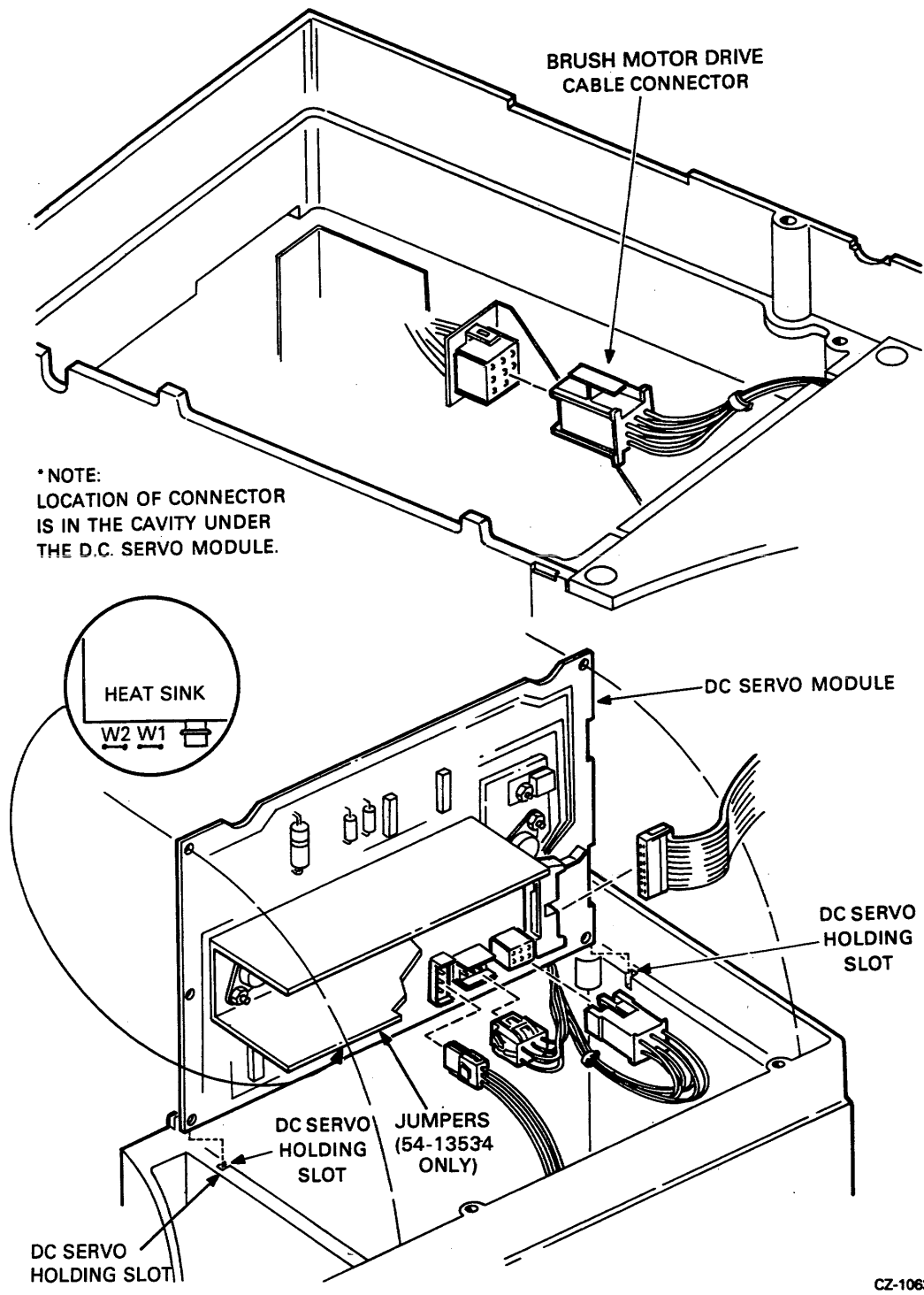

CZ-1063

Figure 2-9 DC Servo Module

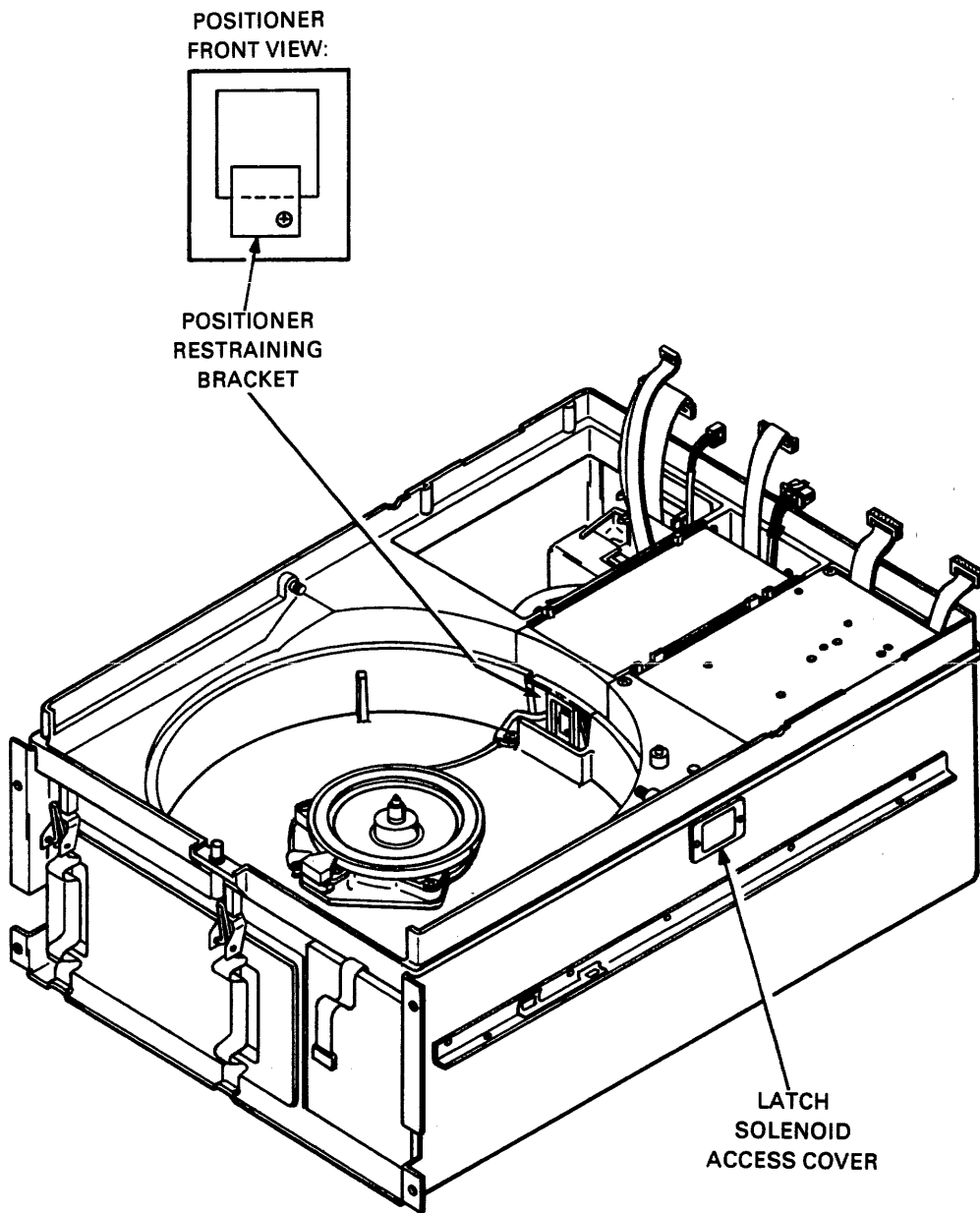

CZ-2003

Figure 2-10 Exposed Drive Baseplate

### **2.4.2 Brush Tips**

The brush tips and brush holder arms are replaced as one unit. To remove the arms (and tips):

1. Remove the brush drive assembly (Paragraph 2.4.2).
2. Invert brush motor assembly and place on work surface. Remove retaining ring and flat-washer (Figure 2-11).
3. Carefully lift on brush drive link assembly at end connecting brush holder assembly, then pivot link assembly out of the way.

#### **CAUTION**

**Too much force may break the plastic locating dowels.**

4. Slide brush holder off mounting shaft.

To replace the brush arms (and tips):

1. Slide new brush holder arms onto mounting shaft (Figure 2-11).
2. Install flatwasher and retaining ring as shown in Figure 2-11.
3. Replace brush drive link assembly onto brush holder dowel as shown in Figure 2-11.
4. Replace the brush drive (Paragraph 2.4.1).

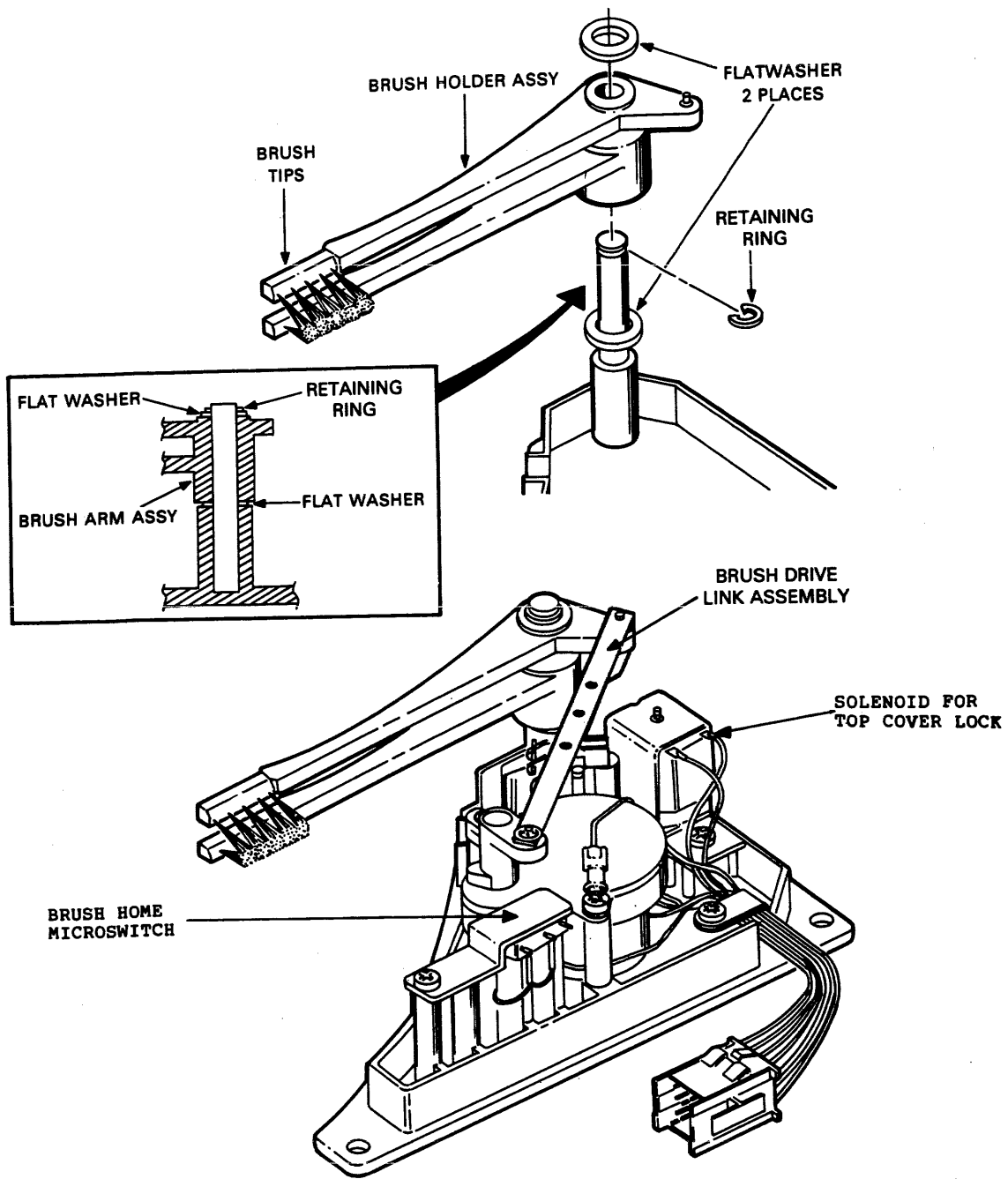

CZ-0013

Figure 2-11 Exposed Brush Drive Assembly

## 2.5 MODULES

### 2.5.1 AC Servo Module

To remove the ac servo module:

1. Unplug the ac power cord.
2. Open the field service access cover (Paragraph 2.3.1).
3. Locate the ac servo module (Figure 2-8). Remove the cover (Figure 2-12) and disconnect all the cables.

#### NOTE

**The cover holddown tabs may have to be bent out of the way in order to lift the module cover.**

4. Unplug all the cables and lift the module out of the drive.

To replace the ac servo module:

1. Slide the module into place.
2. Connect all the cables and replace the cover.
3. Replace the field service access cover (Paragraph 2.3.1).
4. Replace the ac power cord.

### 2.5.2 DC Servo Module

To remove the dc servo module:

1. Unplug the ac power cord.
2. Open the field service access cover (Paragraph 2.3.1).
3. Locate the dc servo module (Figure 2-8).
4. Remove the four screws securing the plastic template and module to the baseplate.
5. Lift the module and disconnect all the cables.

To replace the dc servo module:

1. If the module is Part No. 54-13534, check the jumper configuration (Figure 2-9). For an RL01 drive, both jumpers should be in. For an RL02, W1 should be out. W2 is always in place. If the module is Part No. 54-11850, it only works on an RL01 and has no jumpers. In this case, go directly to Step 2.
2. Connect all cables to the module.
3. Place the module back into the baseplate.
4. Lay the plastic template into position on top of the module and secure it with the four screws.

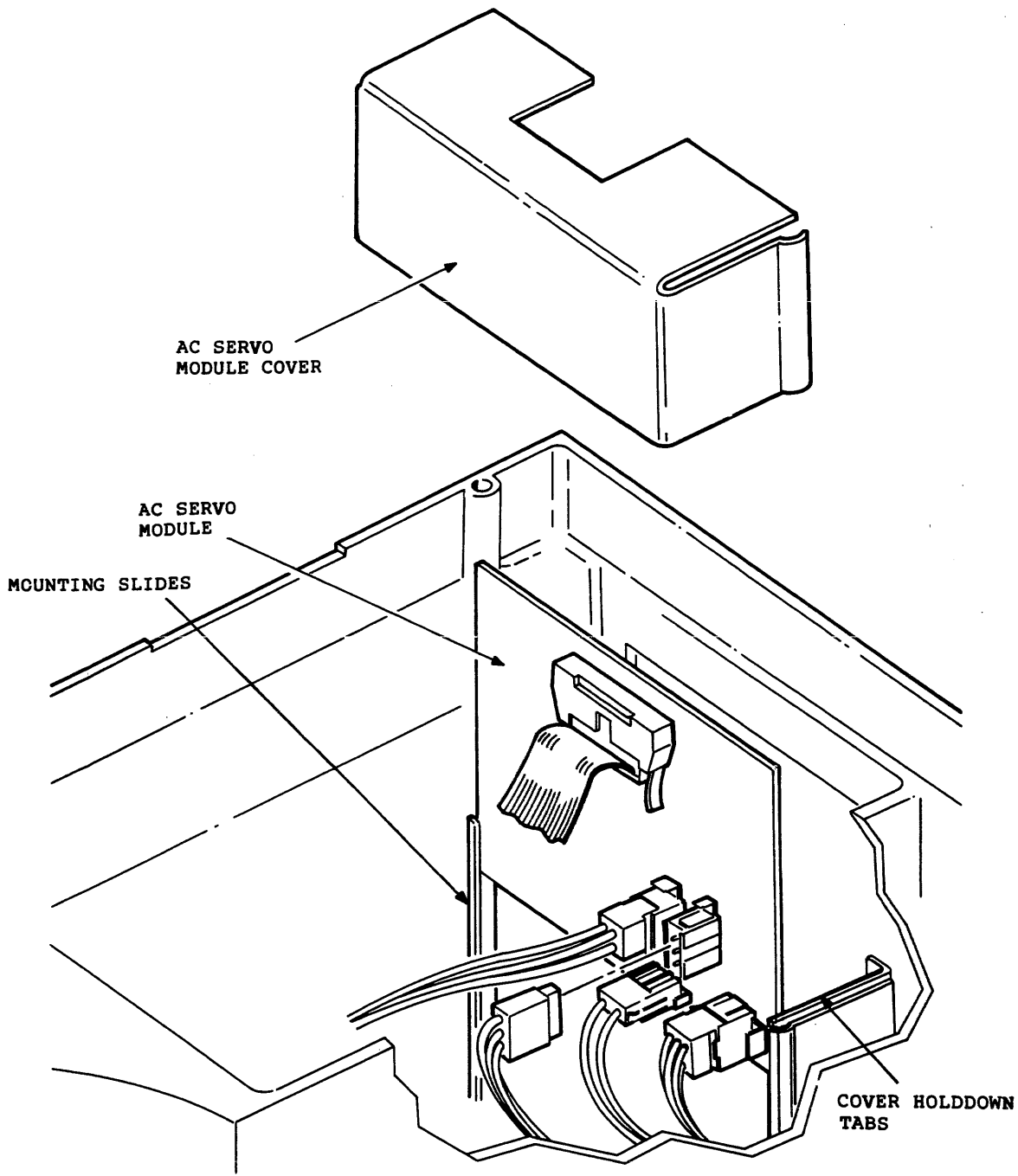

CZ-0014

Figure 2-12 AC Servo Module

### NOTE

If the dc servo module being replaced is the "old" module (Part No. 54-11850), use the "old" template (Part No. 74-18588). If the module being replaced is a "new" module (Part No. 54-13534), it must be covered with a different template (Part No. 70-20826).

5. Replace the field service access cover (Paragraph 2.3.1).
6. Replace the ac power cord.

### 2.5.3 Drive Logic Module

To remove the drive logic module:

1. Open the field service access cover (Paragraph 2.3.1).
2. Remove all cables connected to the drive logic module (Figure 2-8). Be sure to note the orientation of the stripe on each cable.
3. Remove the Phillips head screws holding the module to the cover, and lift out the module.

To replace the drive logic module:

1. If the module is Part No. 54-12175, it works on an RL01 only. Go directly to Step 2. If the module is Part No. 54-13531 or 54-14025, check for jumper W1 (Figure 2-13). For an RL01 drive, the jumper should be in place. For an RL02, it should be out.

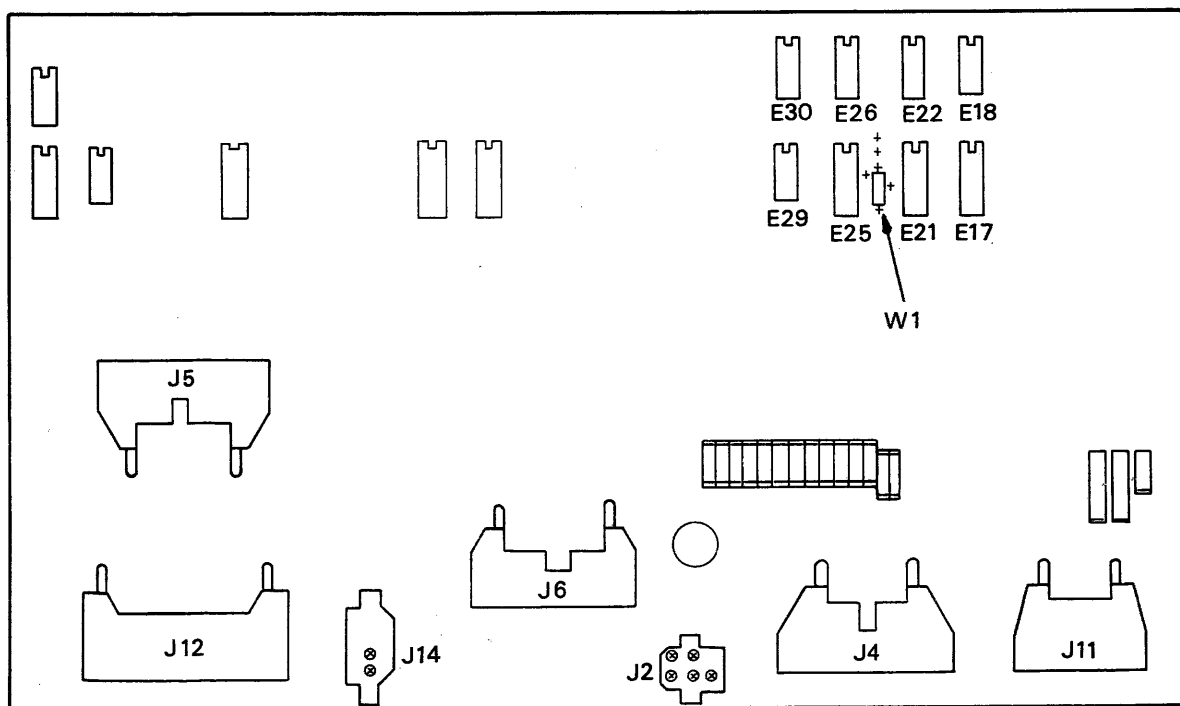

CZ-0701

Figure 2-13 Drive Logic Module W 1 Location



2. Replace the module inside the field service access cover and secure the module with the Phillips head screws.
3. Reconnect the cables to the module.
4. Close the field service access cover (Paragraph 2.3.1).

#### **2.5.4 Read/Write Module**

To remove the read/write module:

1. Remove the disk cartridge (if one is in place).

#### **NOTE**

**The read/write "Assembly" consists of the read/write module and several parts surrounding the module. Only the module itself should be replaced. If the module is ordered by Part No. 54-11844 (RL01) or Part No. 54-13536 (RL01 or RL02), the assembly will not come with it.**

2. Remove the field service access cover (Paragraph 2.3.1).
3. Remove the cartridge access cover (Paragraph 2.3.2).
4. Locate the read/write module assembly (Figure 2-8). If there is a grounding wire connected to the rear of the assembly, disconnect it.
5. Lift the assembly up, rotate it toward the dc servo module and rest it on the baseplate locating pins (Figure 2-14).
6. Disconnect the r/w head cables from the assembly.

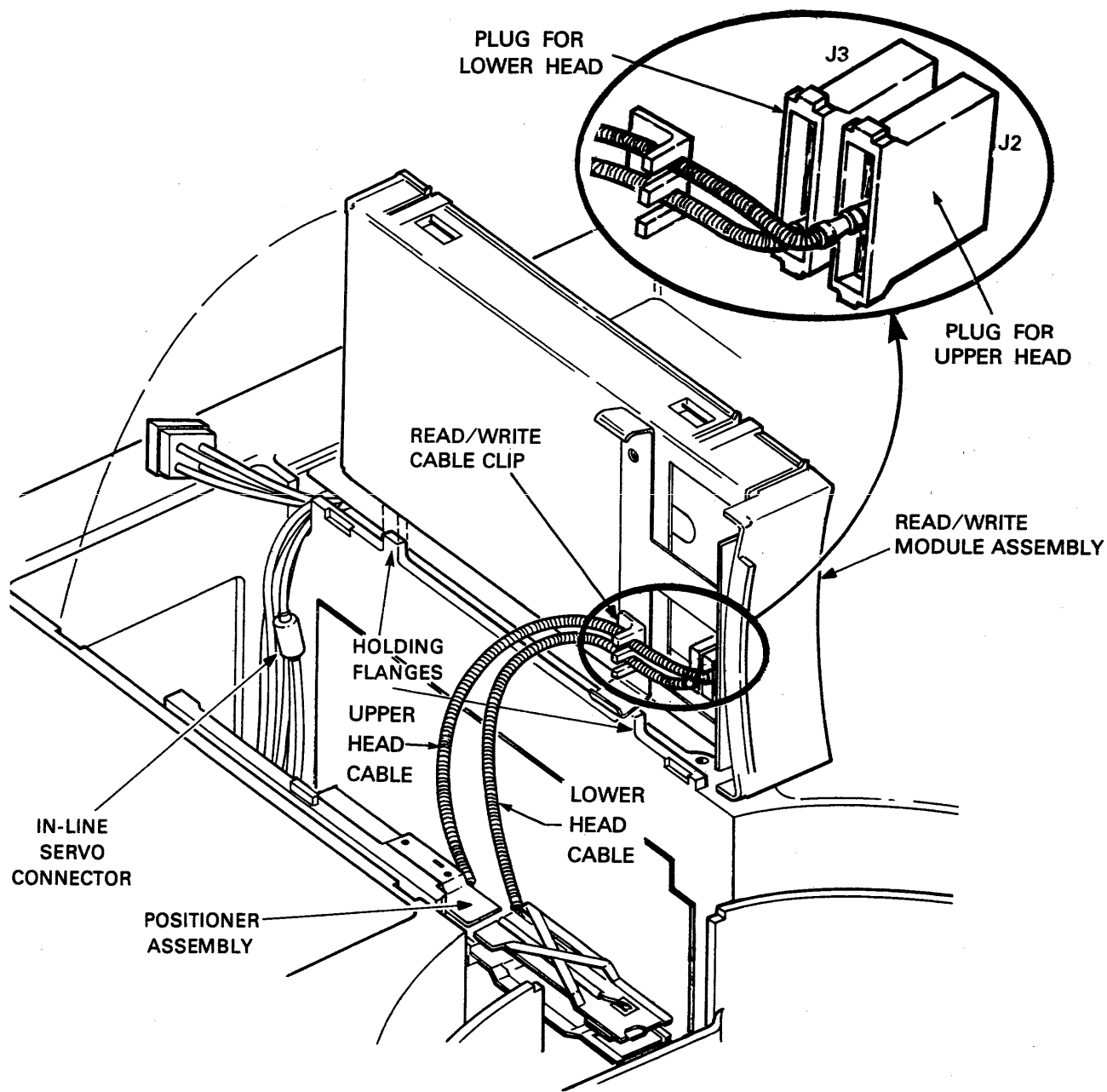

(A) OLDER RL01

CZ-2054

Figure 2-14a Read/Write Module (Upright)  
Old Style

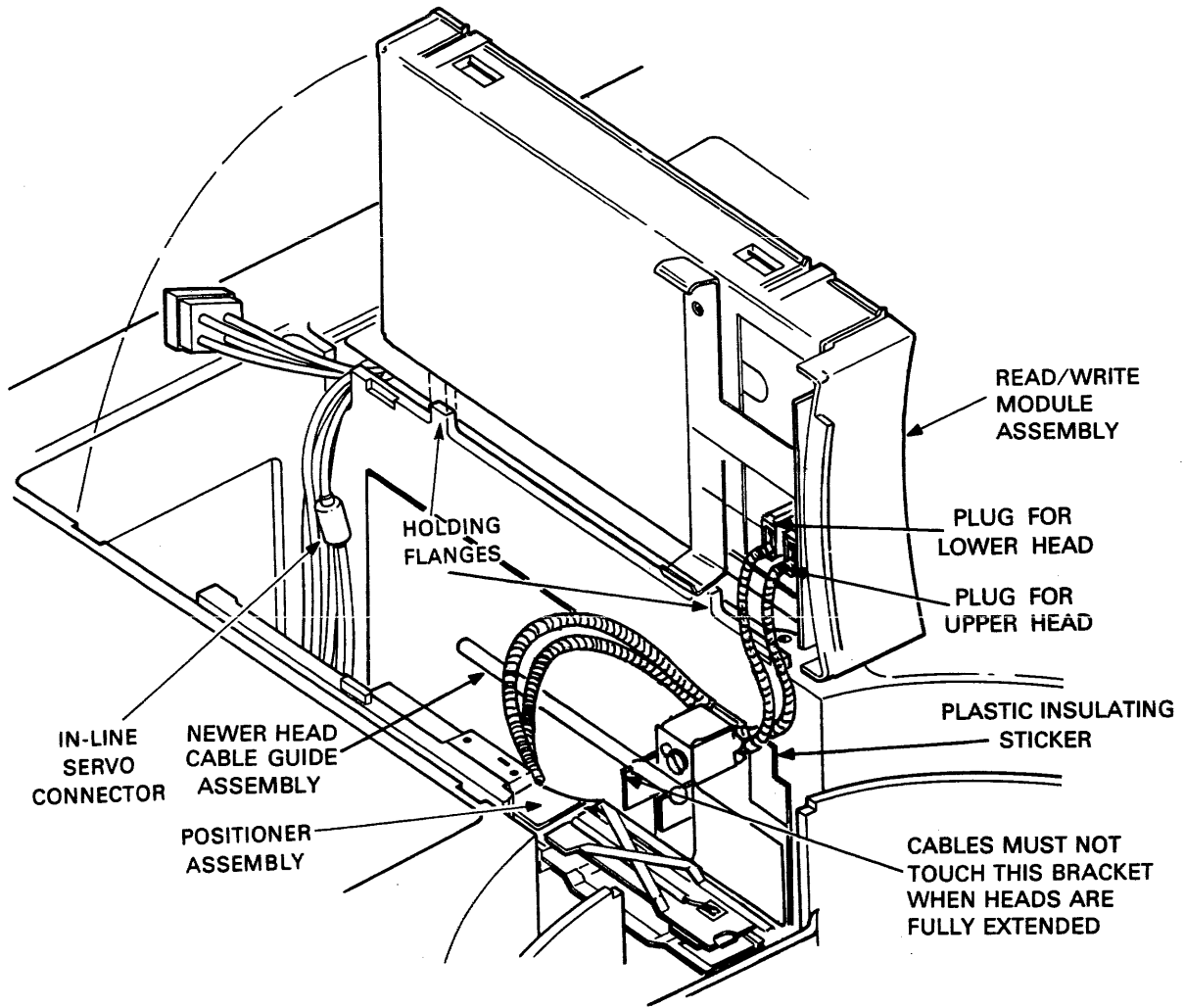

(B) NEWER RL01 AND ANY RL02

CZ-0136

Figure 2-14b Read/Write Module (Upright)  
New Style

7. Remove the top cover of the assembly (Figure 2-15) by carefully prying back the four plastic locking tabs and lifting the cover. This is easily accomplished by prying one tab at a time and lifting the cover slightly at each corner.
8. Remove the front piece of the assembly (Figure 2-15).
9. Remove the module cable.
10. Slide the module out of the pan (Figure 2-15).

To replace the read/write module:

1. If the drive is an RL01, cut jumper W2 but leave in W1. If the drive is an RL02, cut W1 and leave in W2. See Figure 2-15.

**NOTE**

**If the read/write module is Part. No. 54-11844, it will not have the jumper. However, it can only be used on an RL01.**

2. Slide the module into the pan (Figure 2-15).
3. Reconnect the cable to the read/write module.
4. Replace the front piece of the assembly.
5. Replace the top cover of the assembly by pushing down on the cover until the four plastic tabs secure the cover.
6. Reconnect the cables to the assembly (Figure 2-14).
7. Place the assembly back into the baseplate. If there was a grounding wire connected to the rear of the assembly, reconnect it.
8. Replace the cartridge access cover (Paragraph 2.3.2).
9. Replace the field service access cover (Paragraph 2.3.1).

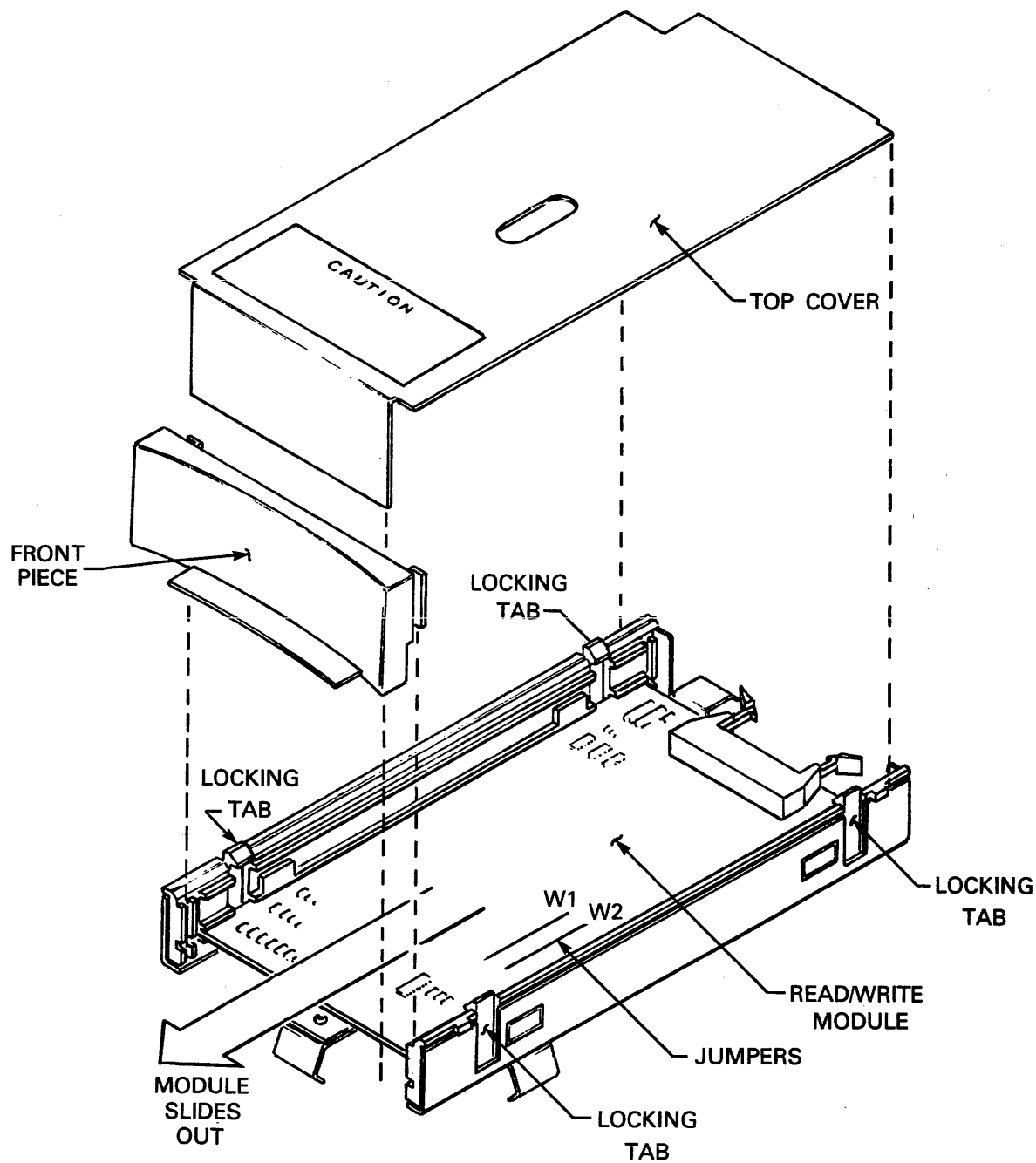

CZ-2055

Figure 2-15 Read/Write Module Box Disassembly

## **2.6 SPINDLE AREA**

### **2.6.1 Belt From Spindle Pulley**

To remove the belt from the spindle pulley:

1. Remove the spindle access cover (see Figure 2-16).
2. Slip belt off the spindle pulley.

To replace the belt on the spindle pulley:

1. Slide the drive belt on the pulley and rotate the spindle so that the pulley will drag the belt onto itself.
2. Replace the spindle access cover.

### **2.6.2 Spindle Ground Button**

To remove the spindle ground button:

1. Remove the spindle access cover (see Figure 2-16).
2. Using Figure 2-17 as a guide, pull down on the ground brush strap enough to allow the ground brush to drop.

To replace the spindle ground button:

1. Pull down on the ground brush spring just enough to insert the ground brush (Figure 2-17).
2. Rotate the spindle several times to ensure firm seating and to check that the spindle does not bind.
3. Replace the spindle access cover (see Figure 2-16).

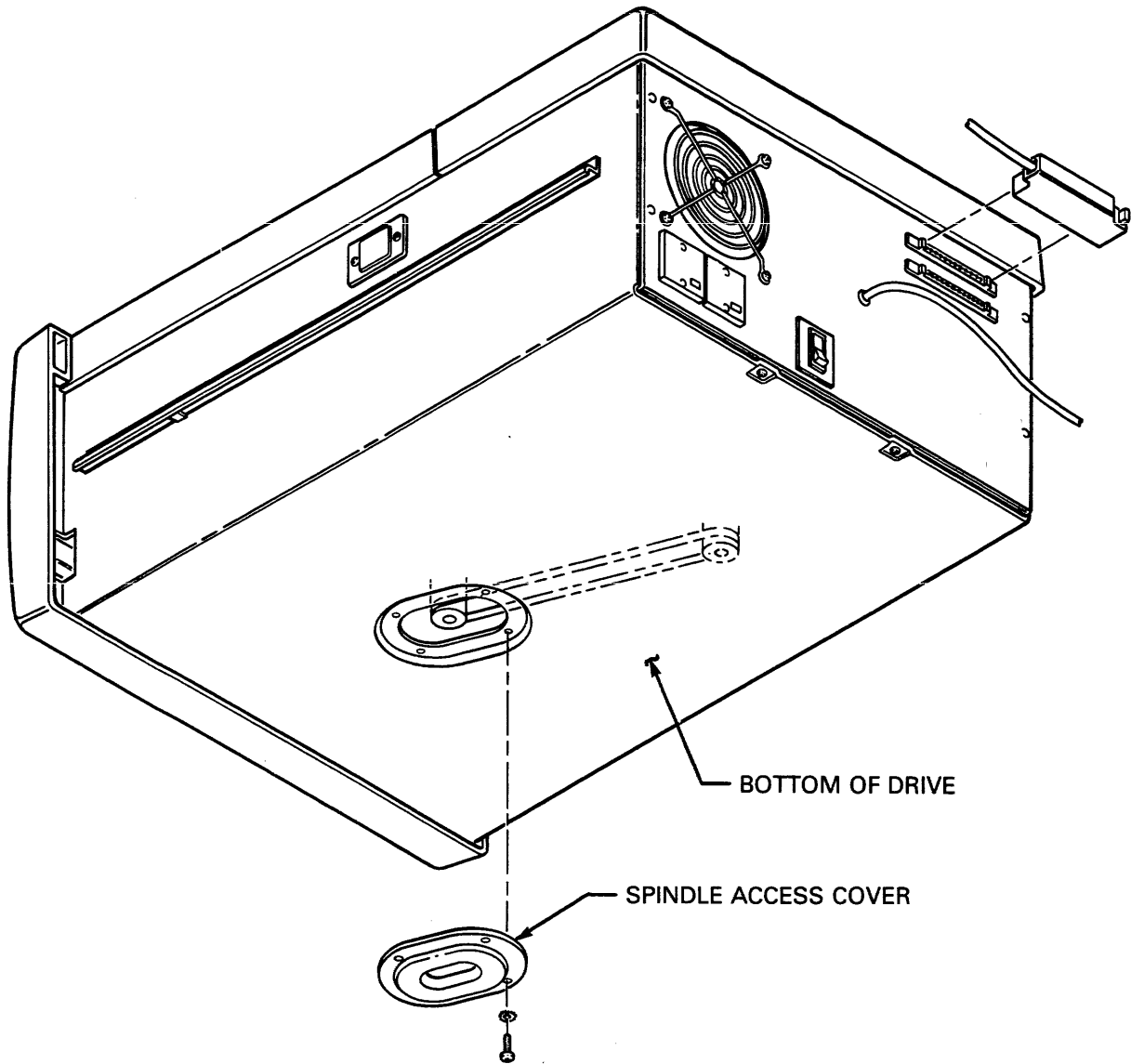
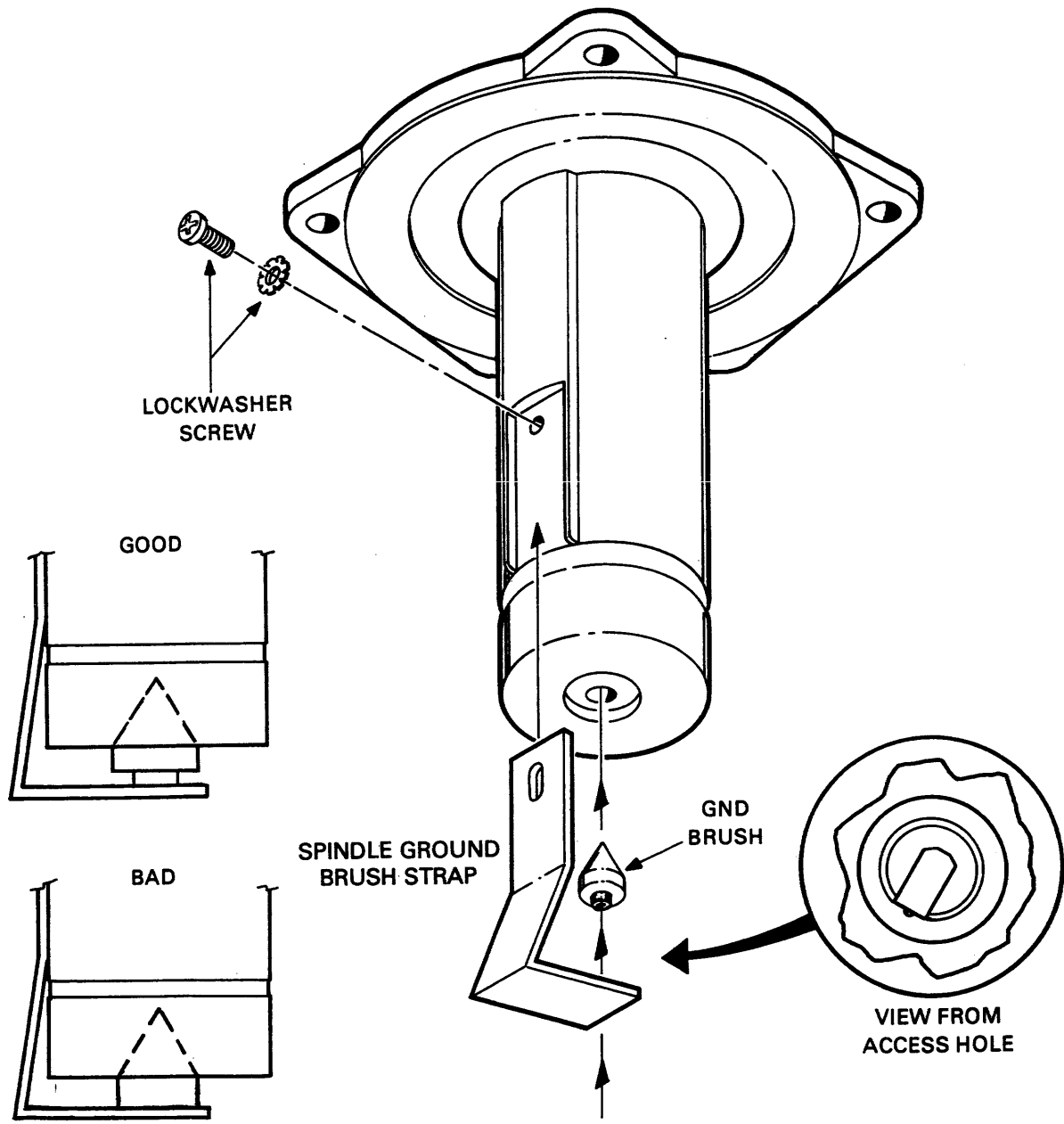

Figure 2-16 Spindle Access Cover

CZ-1060



CZ-2029

Figure 2-17 Spindle Ground Button



### **2.6.3 Spindle**

To remove the spindle:

1. Remove the field service access cover (Paragraph 2.3.1).
2. Remove the cartridge access cover (Paragraph 2.3.2).
3. Remove the belt from the spindle pulley (Paragraph 2.6.1).
4. Remove the two screws holding the sector transducer to the spindle (Figure 2-18).
5. Remove the cable clamp (one screw) holding the sector transducer cable to the spindle (Figure 2-18).
6. Lift the spindle straight up out of the baseplate.

To replace the spindle:

1. Insert the spindle into the baseplate. Position the spindle so that the locating pin fits into the recess in the spindle assembly.
2. Secure the spindle to the baseplate with three Phillips head screws.
3. Replace the belt on the pulley (Paragraph 2.6.1).
4. Replace the cartridge access cover (Paragraph 2.3.2).
5. Replace the field service access cover (Paragraph 2.3.1).

### **2.6.4 Sector Transducer**

To remove the sector transducer:

1. Remove the field service access cover (Paragraph 2.2.1).
2. Remove the cartridge access cover (Paragraph 2.3.2).
3. Remove the two screws holding the transducer to the spindle (Figure 2-18).
4. Remove the screw holding the transducer cable clamp to the spindle (Figure 2-18).
5. Remove the screw holding the transducer ground lug to the baseplate.
6. Remove the three other cable clamp screws.
7. Unplug the cable from the drive logic module, noting the orientation of the stripe on the cable.
8. Remove the transducer cable, noting the path of cable routing.

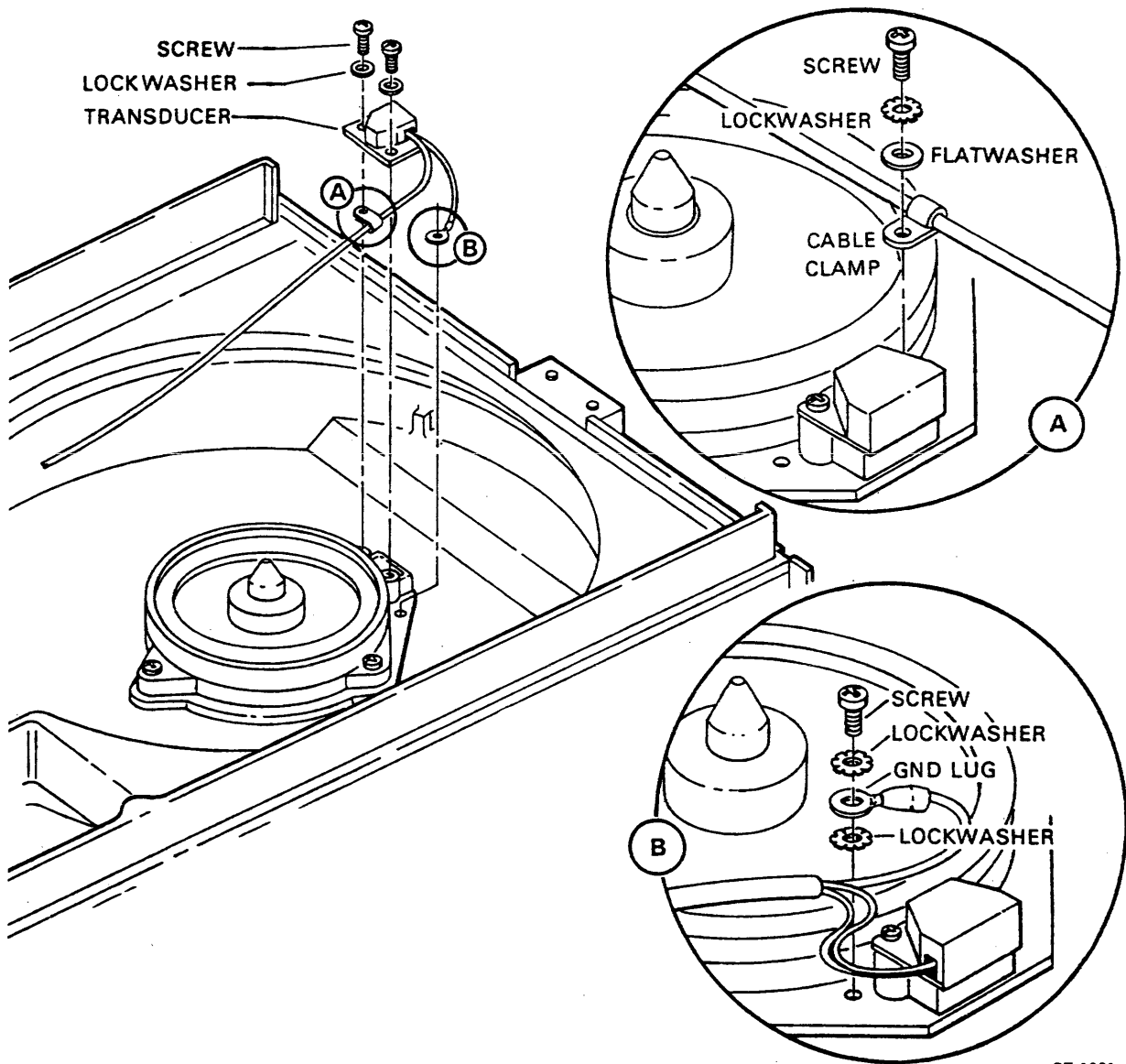

CZ-1061

Figure 2-18 Sector Transducer Mounting

To replace the sector transducer:

1. Route the transducer cable in the drive, following the path of removal.
2. Replace the three screws in the cable clamps and reinstall into the baseplate.
3. Replace the screw holding the transducer ground lug to the baseplate (Figure 2-18).
4. Replace the screw holding the transducer cable clamp to the spindle (Figure 2-18).
5. Replace the two screws holding the transducer to the spindle (Figure 2-18).
6. Replace the cartridge access cover (Paragraph 2.3.2).
7. Replace the field service access cover (Paragraph 2.3.1).

## 2.7 POSITIONER AREA

### 2.7.1 Positioner

There are two different types of read/write head cable guides. The older one, as shown in Figure 2-14a, is only on “early” RL01 drives. The newer one, shown in Figure 2-14b, is on all RL02 and “later” RL01 drives.

#### NOTE

To determine whether an RL01 is an “early” or “later” drive, look at the positioner assembly. If there is no head cable guide on the positioner (Figure 2-14a), it is an older drive. If the head cable guide is there, it is a newer drive.

If the positioner is being replaced in an early RL01, follow the procedure in Paragraph 2.7.1.1. If the positioner is being replaced in a later RL01 or an RL02, follow the procedure in Paragraph 2.7.1.2. If an early RL01 is having intermittent read check errors, the old cable guide (on the read/write module assembly) may be removed and the new one installed, as described in Paragraph 2.7.1.3. The part number for the kit containing the new cable guide is given in Field Change Order CX-0035.

#### NOTE

When the positioner (70-12117) is ordered, it will NOT come with the new head cable guide kit. This must be ordered separately.

#### 2.7.1.1 Positioner in Early RL01

To remove the positioner:

1. Remove the field service access cover (Paragraph 2.3.1).
2. Remove the cartridge access cover (Paragraph 2.3.2).
3. Remove the dc servo module (removal Steps 1 through 4, Paragraph 2.5.2).
4. Disconnect positioner cable and place the module back into the baseplate.

5. Lift up the read/write module assembly, rotate it toward the dc servo module and remove the head cables from the module assembly (Figure 2-14a).
6. Remove the six screws holding the positioner to the baseplate (Figure 2-19).
7. Lift the positioner up and out of the drive area.
8. Remove the read/write heads from the positioner (Paragraph 2.7.2).

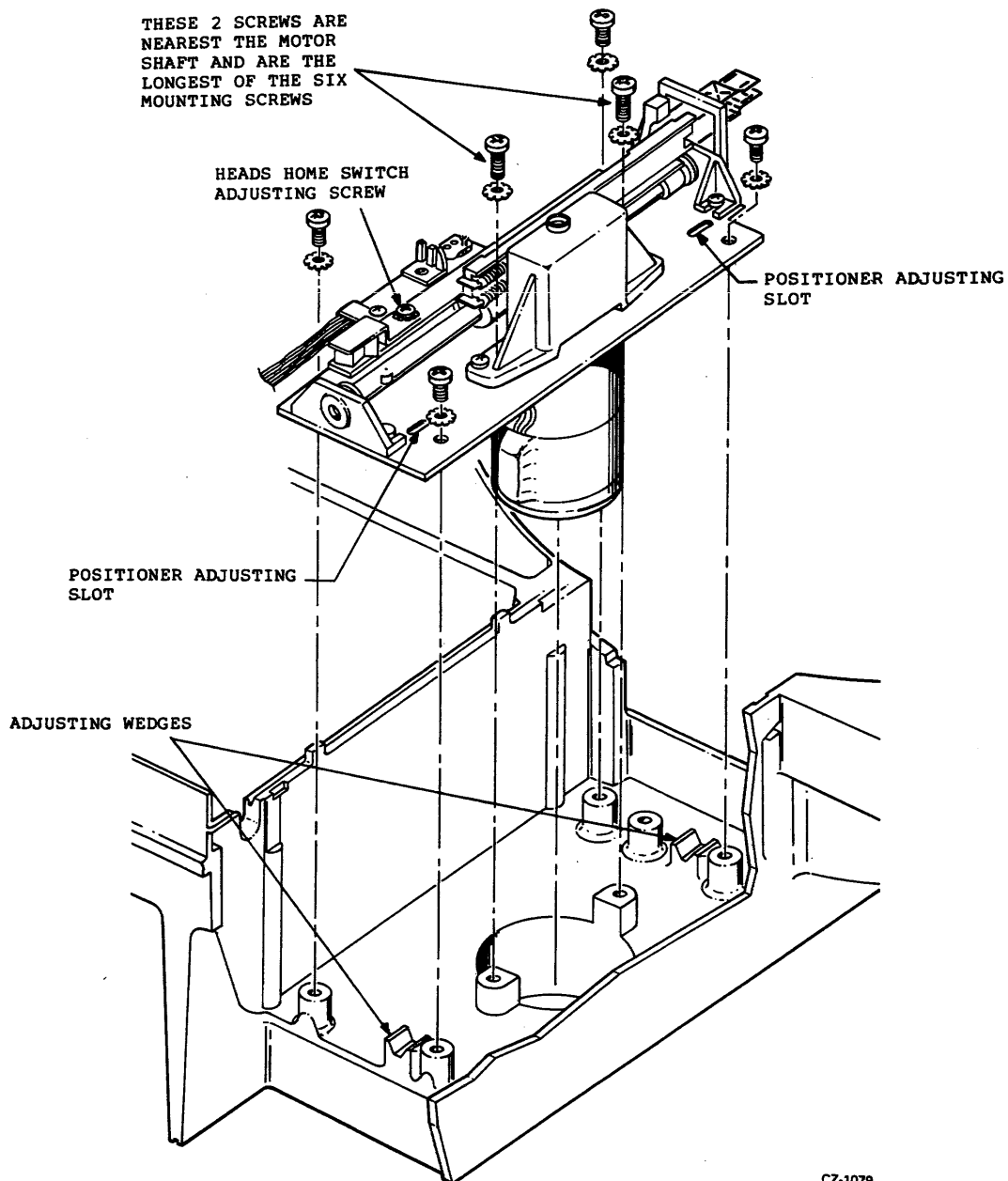

Figure 2-19 Positioner Assembly

To replace the positioner:

1. Replace the read/write heads on the positioner (Paragraph 2.7.2).
2. Place the positioner back into the baseplate of the drive.

**NOTE**

**The positioner is fragile. Do not drop it into place.  
Lower it gently.**

3. Secure the positioner to the baseplate with the six Phillips head screws (Figure 2-19).
4. Place the head cables back into the module assembly (Figure 2-14a).
5. Replace positioner plug onto dc servo module.
6. Place the read/write module assembly into the baseplate.
7. Replace the cartridge access cover (Paragraph 2.3.2).
8. Replace the field service access cover (Paragraph 2.3.1).
9. Perform the positioner radial alignment (Chapter 3, Paragraph 3.6) and the head alignment (Chapter 3, Paragraph 3.7).

**2.7.1.2 Positioner in Newer RL01 and Any RL02**

To remove the positioner:

1. Remove the field service access cover (Paragraph 2.3.1).
2. Remove the cartridge access cover (Paragraph 2.3.2).
3. Remove the dc servo module (removal procedure Steps 1 through 4, Paragraph 2.5.2).
4. Disconnect positioner cable and place the module back into the baseplate.
5. Lift up the read/write module assembly, rotate it toward the dc servo module and remove the head cables from the module assembly (Figure 2-14b).
6. Place the read/write module assembly on the baseplate locating flanges.
7. Remove the six screws holding the positioner to the baseplate (Figure 2-19).
8. Lift the positioner up and out of the drive area.
9. Remove the head cables from the cable guide assembly.
10. Remove the read/write heads from the positioner (Paragraph 2.7.2).
11. Loosen the screw holding the cable guide to the tachometer guide rod and remove the cable guide assembly (Figure 2-20).

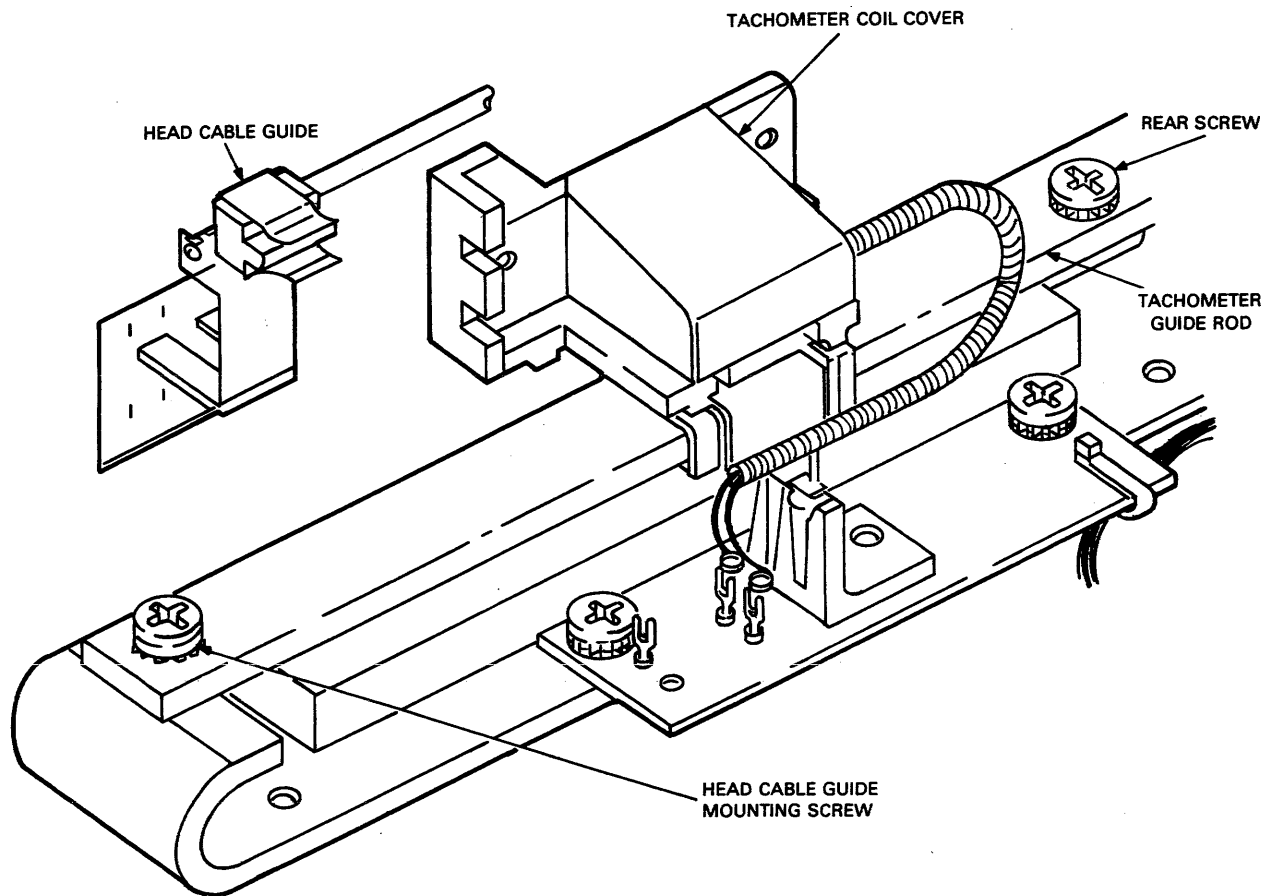

CZ-0133

Figure 2-20 Head Cable Guide

To replace the positioner:

1. Ensure that the rear screw on the tachometer guide rod is tight (see Figure 2-20).
2. Replace the head cable guide assembly (Figure 2-14b).
3. Upon installation of the head cable guide assembly, ensure that the guide rod does not touch the tachometer coil cover. If the rod does touch the cover, adjust the cable guide assembly. Check through the full range of carriage travel (Figure 2-20).
4. Replace the read/write heads on the positioner (Paragraph 2.7.2).
5. Place the positioner back into the baseplate of the drive.

**NOTE**

**The positioner is fragile. Do not drop it into place.  
Lower it gently.**

6. Secure the positioner to the baseplate with the six Phillips head screws (Figure 2-19).

7. Replace positioner plug onto dc servo module.
8. Replace dc servo module (Paragraph 2.5.2).
9. Place the head cable plugs into the read/write module assembly (Figure 2-14b).
10. Power up the drive, install a pack in the drive, and load the heads.
11. Manually move the heads toward the spindle, as far as they will go.
12. Mount the head cables into the clips on the cable guide. The cable for the lower head should go into the lower clip (Figure 2-14b).
13. Ensure that the cables do not touch the corner of the cable guide bracket (as shown in Figure 2-14b). If they do, readjust the cables in the clip so that they do not touch the corner of the bracket.

**NOTE**

**The positioner MUST be fully extended when performing this check.**

**NOTE**

**The read/write module assembly will have to be removed from the baseplate holding flanges and held in one hand to readjust the cables, as the cables are not long enough to reach.**

14. Retract the heads, power down the drive, and remove the pack.
15. Place the read/write module assembly into the baseplate.
16. Replace the cartridge access cover (Paragraph 2.3.2).
17. Replace the field service access cover (Paragraph 2.3.1).
18. Perform the Positioner Radial Alignment (Chapter 3, Paragraph 3.6) and the Head Alignment (Chapter 3, Paragraph 3.7).

### **2.7.1.3 New Head Cable Guide in Older RL01**

To install a new head cable guide:

1. Remove the field service access cover (Paragraph 2.3.1).
2. Remove the cartridge access cover (Paragraph 2.3.2).
3. Disassemble the read/write module assembly (Paragraph 2.5.4).
4. Mount the plastic insulating sticker on the drive (Figures 2-14b and 2-21).
5. Remove the read/write cable clip from the read/write module assembly by removing the screw. Discard both the screw and the cable clip.

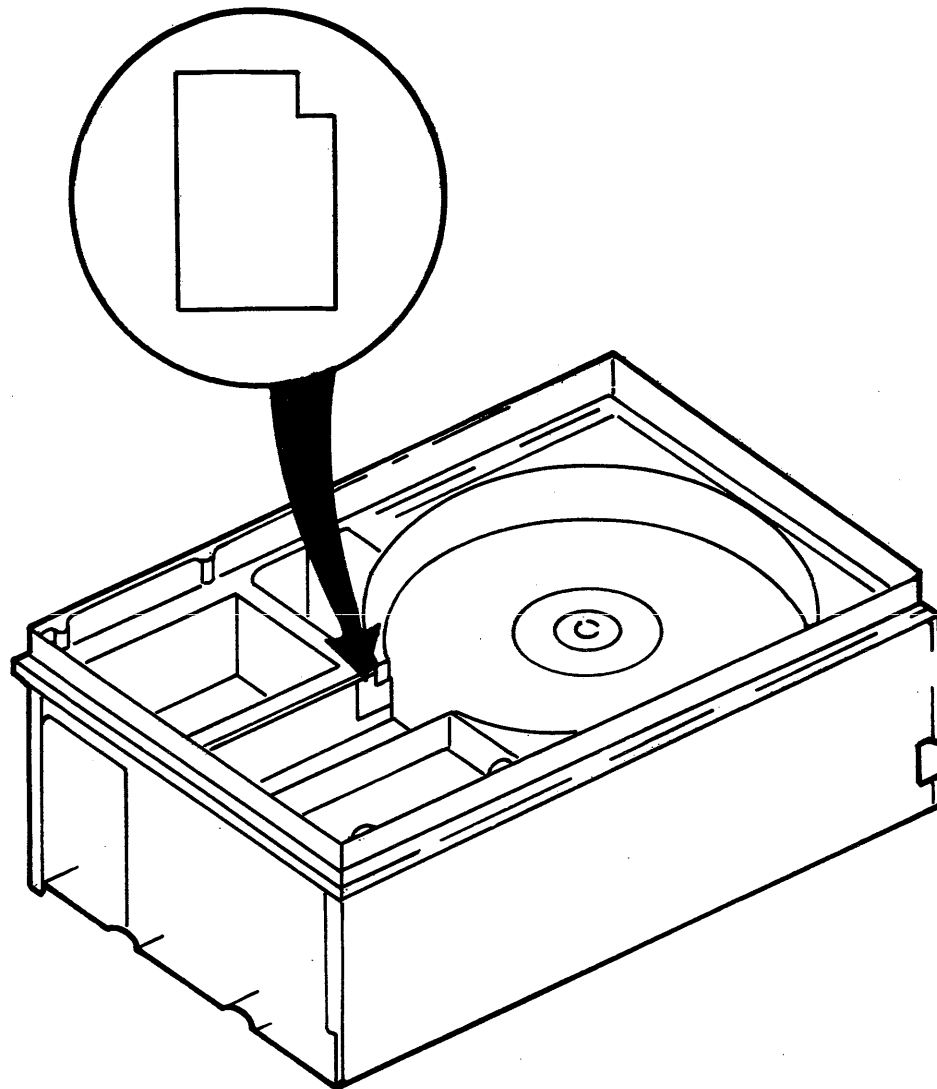

CZ-0134

Figure 2-21 Location of Plastic Insulating Sticker

6. Reassemble the read/write module assembly (Paragraph 2.5.4, replacement Steps 1 through 5).
7. Power up the drive, install a pack in the drive, and load the heads.
8. Manually move the heads out toward the spindle, as far as they will go.
9. Tighten rear screw, loosen front screw (Figure 2-20).
10. Attach the new head cable guide, with the rod pointing toward the rear of the drive (Figures 2-14b and 2-20).
11. Ensure that the rod does not touch the tachometer coil cover. If it does, adjust the cable guide. Check through full range of carriage travel.



12. Manually move the heads toward the spindle, as far as they will go.
13. Mount the head cables into the clips on the cable guide. The cable for the lower head should go into the lower clip (Figure 2-14b).
14. Ensure that the cables do not touch the corner of the cable guide bracket (as shown in Figure 2-14b). If they do, readjust the cables in the clip so that they do not touch the corner of the bracket.

**NOTE**

**The positioner MUST be fully extended when performing this check.**

**NOTE**

**The read/write module assembly will have to be removed from the baseplate holding flanges and held in one hand to readjust the cables, as the cables are not long enough to reach.**

15. Retract the heads, power down the drive, and remove the pack.
16. Place the read/write module assembly into the baseplate.
17. Replace the cartridge access cover (Paragraph 2.3.2).
18. Replace the field service access cover (Paragraph 2.3.1).

### **2.7.2 Read/Write Heads**

To remove the read/write heads:

1. Remove the field service access cover (Paragraph 2.3.1).
2. Remove the cartridge access cover (Paragraph 2.3.2).
3. Remove the read/write module assembly (Paragraph 2.5.4).
4. Disconnect the head cables from the module assembly (Figure 2-14).
5. Use a 3/32" Allen wrench to loosen the captive head retaining screw and carefully slide the head forward, out of the positioner assembly (Figure 2-22).

**CAUTION**

**Do not allow the head being removed to bump or drag on the other head during the procedure.**

6. Repeat for the other head.

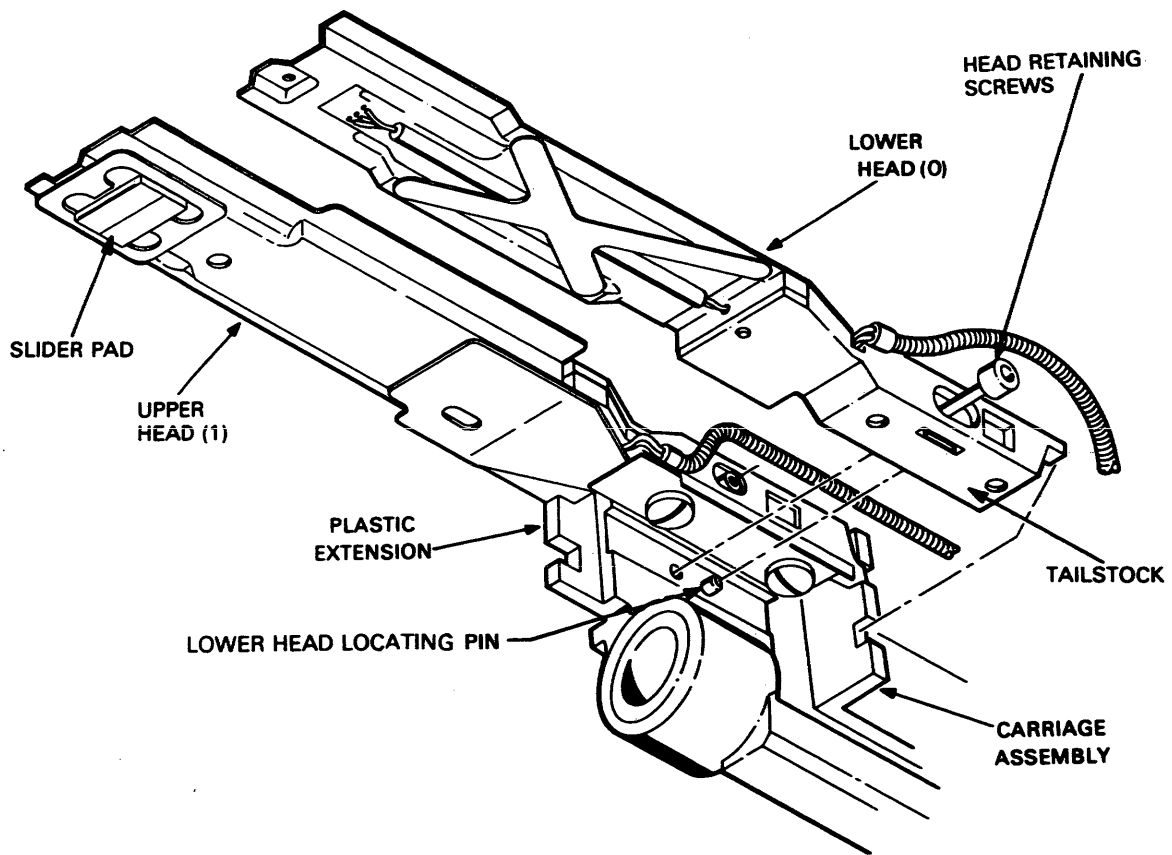

CZ-0728

Figure 2-22 Read/Write Heads

To replace the read/write heads:

1. Insert the lower head into the positioner frame such that:
  - The locating pin (Figure 2-22) is in the recess of the tailstock of the head
  - The tailstock fits into the carriage assembly
  - The corner of the head fits into the plastic extension
2. Slide the head to the rear of the drive so that the head is up against the locating pin.
3. Using the 3/32" Allen wrench, snug the holddown screw to secure the head in place.

**CAUTION**

**The screw is being tightened into an aluminum casting. Do not overtighten this screw so no damage will occur to the threads in the casting.**

4. Insert the upper head into the positioner frame, being careful not to strike the lower head.
5. Secure with the holddown screw.
6. Reconnect the head cables into the read/write module connectors (Figure 2-14). The lower head cable (J3) is inserted into the connector to the left of the upper head cable connector. The J3 connector is the one closer to the rear of the drive.
7. Replace the read/write module assembly (Paragraph 2.5.4).
8. Replace the cartridge access cover (Paragraph 2.3.2).
9. Replace the field service access cover (Paragraph 2.3.1).
10. Perform the read/write head alignment (Paragraph 3.7).

## **2.8 REAR PANEL AREA**

### **2.8.1 Power Supply**

To remove the power supply:

1. Remove the drive from the slide rails (Paragraph 2.2.5, Steps 1 through 3).
2. Remove the field service access cover (Paragraph 2.3.1).
3. Remove the cartridge access cover (Paragraph 2.3.2).
4. Remove the ac servo module (Paragraph 2.5.1).
5. Remove the dc servo module (Paragraph 2.5.2, Steps 1 through 4).
6. Place the dc servo module on its edge in the mounting slots provided (Figure 2-9) and disconnect cable J1.

7. Disconnect brush motor drive cable from its connector (Figure 2-19).
8. At the rear of the drive, remove the six mounting screws (Figure 2-23).

**CAUTION**

The power panel assembly will swing out away from the drive after the last screw is removed. Therefore, the power supply panel should be held firmly in place until the last screw is removed.

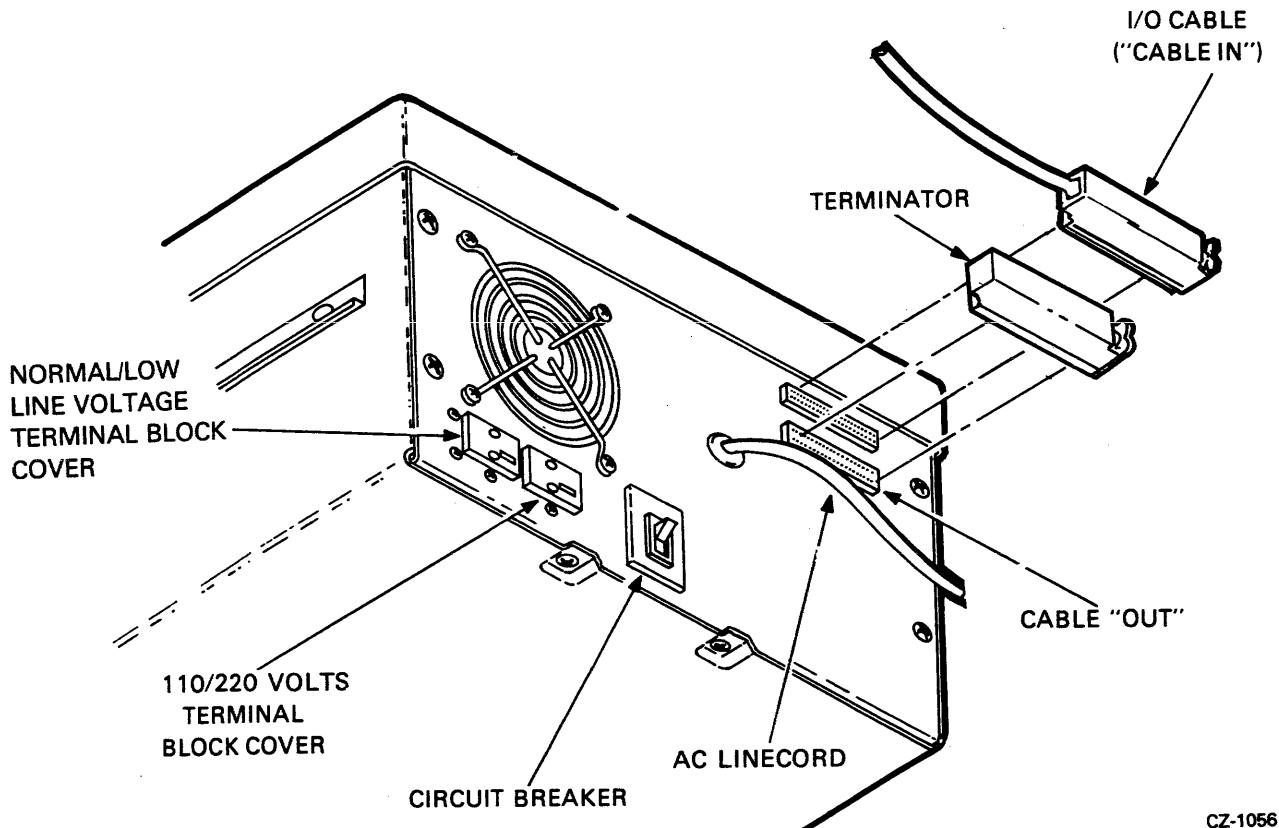
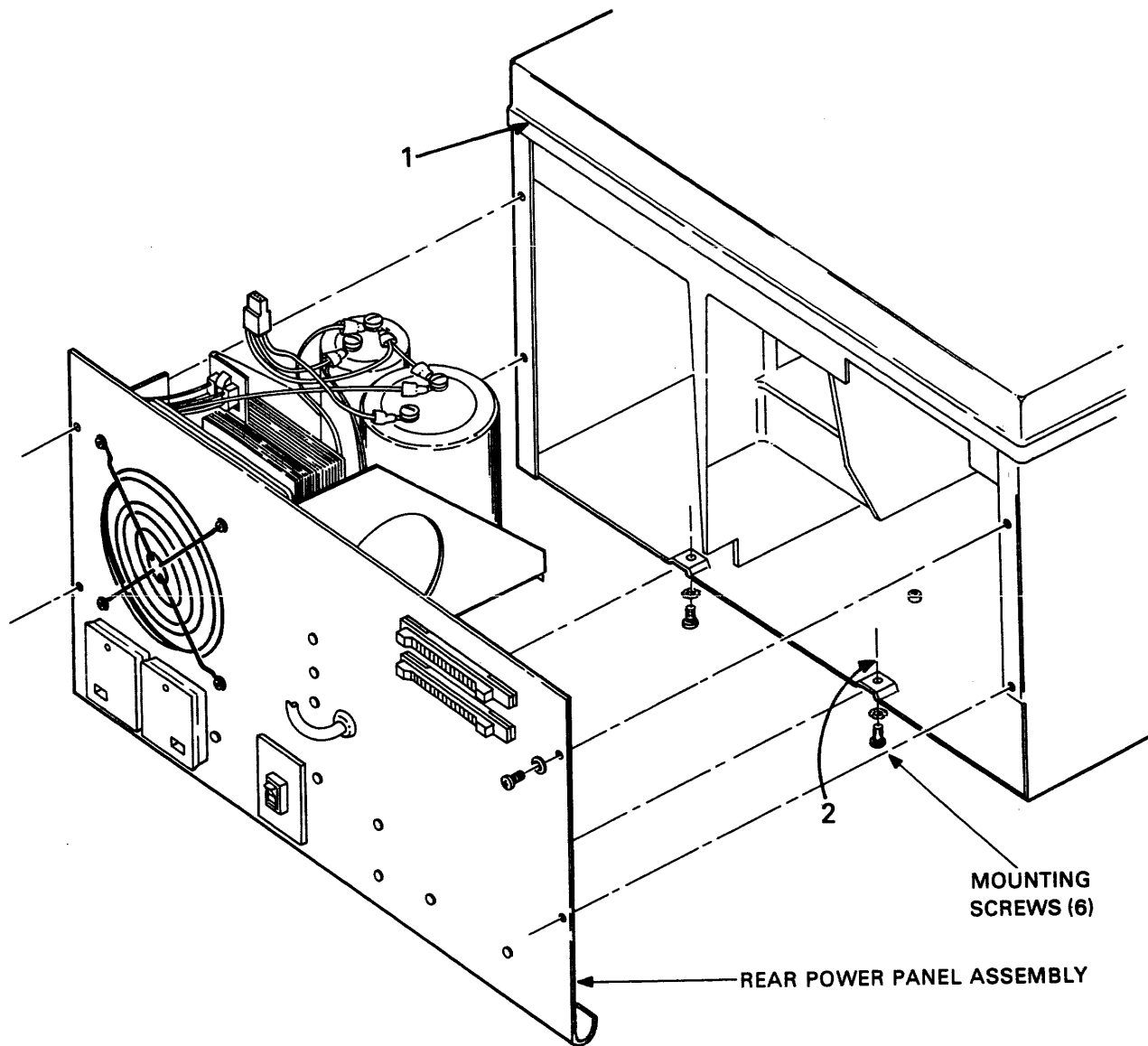

Figure 2-23 Rear View of Drive

To replace the power panel assembly:

1. Slide the rear panel assembly into the rear of the drive, ensuring that:
  - The top edge of the panel fits *under* the rear casting flange (see Figure 2-24, callout #1)
  - The bottom edge of the panel fits *over* the bottom pan of the drive (see Figure 2-24, callout #2)
2. While holding the panel firmly, start the two bottom screws so that the panel will be held in place for the remaining four screws.



CZ-0015

Figure 2-24 Rear Panel Assembly

3. Reconnect J1 of the dc servo module.
4. Reconnect the brush motor drive cable (Figure 2-9).
5. Replace the dc servo module (Paragraph 2.5.2).
6. Replace the ac servo module (Paragraph 2.5.1).
7. Replace the cartridge access cover (Paragraph 2.3.2).
8. Replace the field service access cover (Paragraph 2.3.1).
9. Replace the drive into the cabinet (Paragraph 2.2.5).

### **2.8.2 Spindle Drive Belt**

To remove the spindle drive belt:

1. Remove the power supply (Paragraph 2.8.1).
2. Remove the belt from the spindle pulley (Figure 2-15).
3. Remove the drive motor tension spring from the motor housing (Figure 2-25).
4. Pull belt out through the back of the drive.

To replace the spindle drive belt:

1. Ensure the drive motor housing is as far forward in the drive as it will go.
2. Slip belt under housing (around the drive motor pulley) and slide the belt in the direction of the spindle pulley.
3. From the access in the bottom of the drive, slip the belt onto the spindle pulley.
4. Ensure the belt is still on the motor housing pulley.
5. Slide drive motor housing as far to the rear of the drive as it will go, and reinstall the tension spring.
6. Rotate the spindle several times to position the belt on the self-centering pulleys and check for binding and/or twists in the belt.
7. The belt should have proper tension as applied by the tension spring. Figure 2-26 illustrates the proper belt tension.
8. Reinstall the power supply panel (Paragraph 2.8.1).

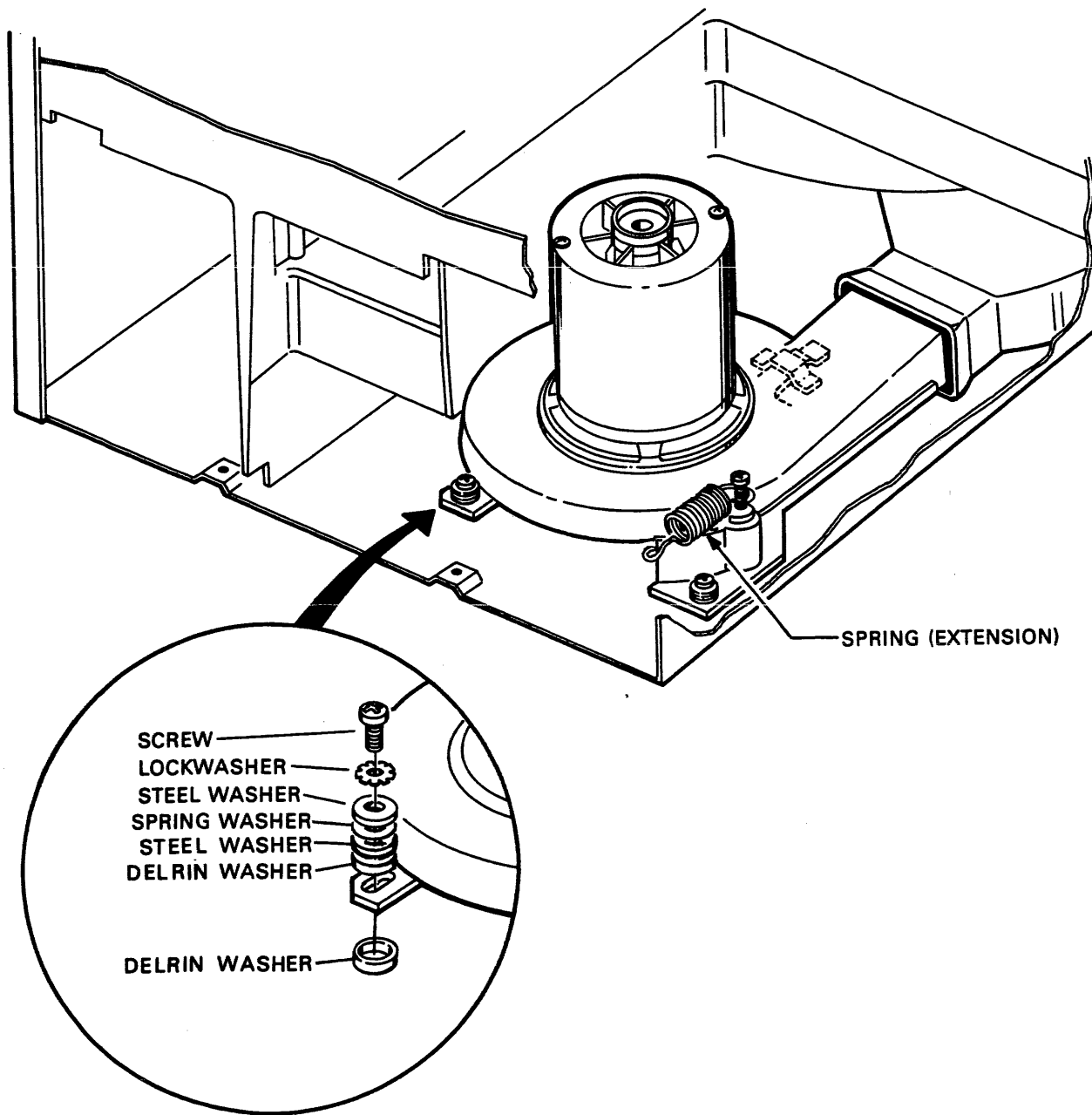

CZ-1062

Figure 2-25 Drive Motor Mounting

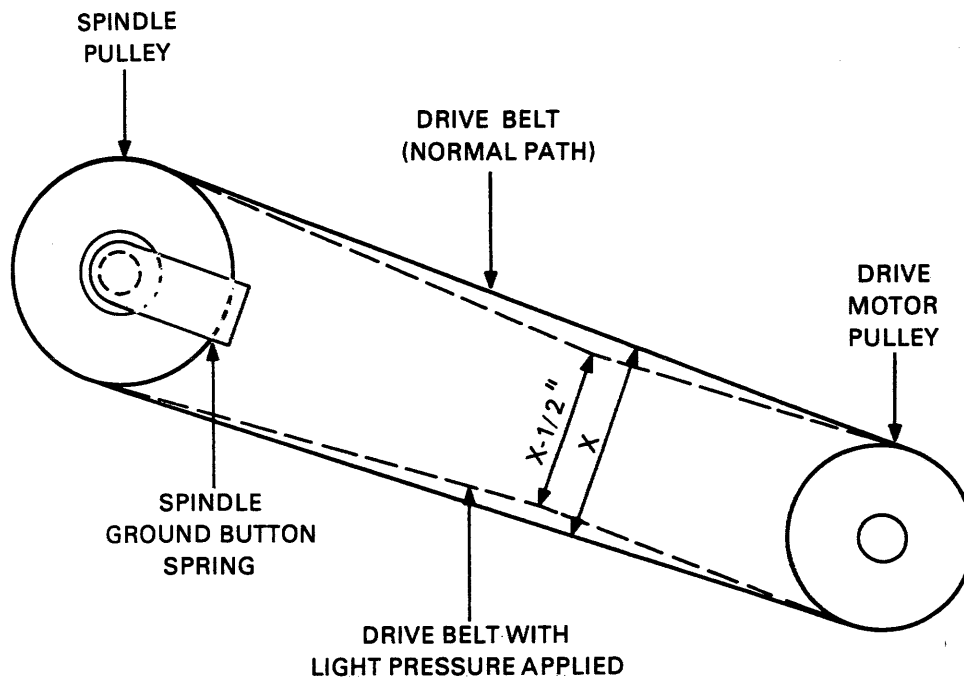

CZ-0016

Figure 2-26 Drive Belt Tension

### 2.8.3 Power Supply Fan

To remove the power supply fan:

1. Remove the power supply (Paragraph 2.8.1).
2. Disconnect the ac plug to the fan.
3. Remove the four screws and nuts holding the fan in place (Figure 2-27). The bottom two nuts can be accessed with an open-end wrench or a pair of long-nosed pliers.

To replace the power supply fan:

1. Place the fan in place with the ac socket located on the top and the airflow direction arrow pointing to the rear of the assembly.
2. Reinstall the four screws securing the fan and finger guard.
3. Reinstall the power supply (Paragraph 2.8.1).



## 2.8.4 Circuit Breaker

To remove the circuit breaker:

1. Remove the power supply (Paragraph 2.8.1).
2. Locate the circuit breaker (Figure 2-27) and mark the wires going to the four breaker terminals.
3. Remove the four wires on the breaker assembly.
4. Squeeze on the four plastic holding tabs (two on the top of the breaker and two on the bottom) to release the breaker from the panel (Figure 2-27).
5. Slide the breaker out the panel, toward the rear.

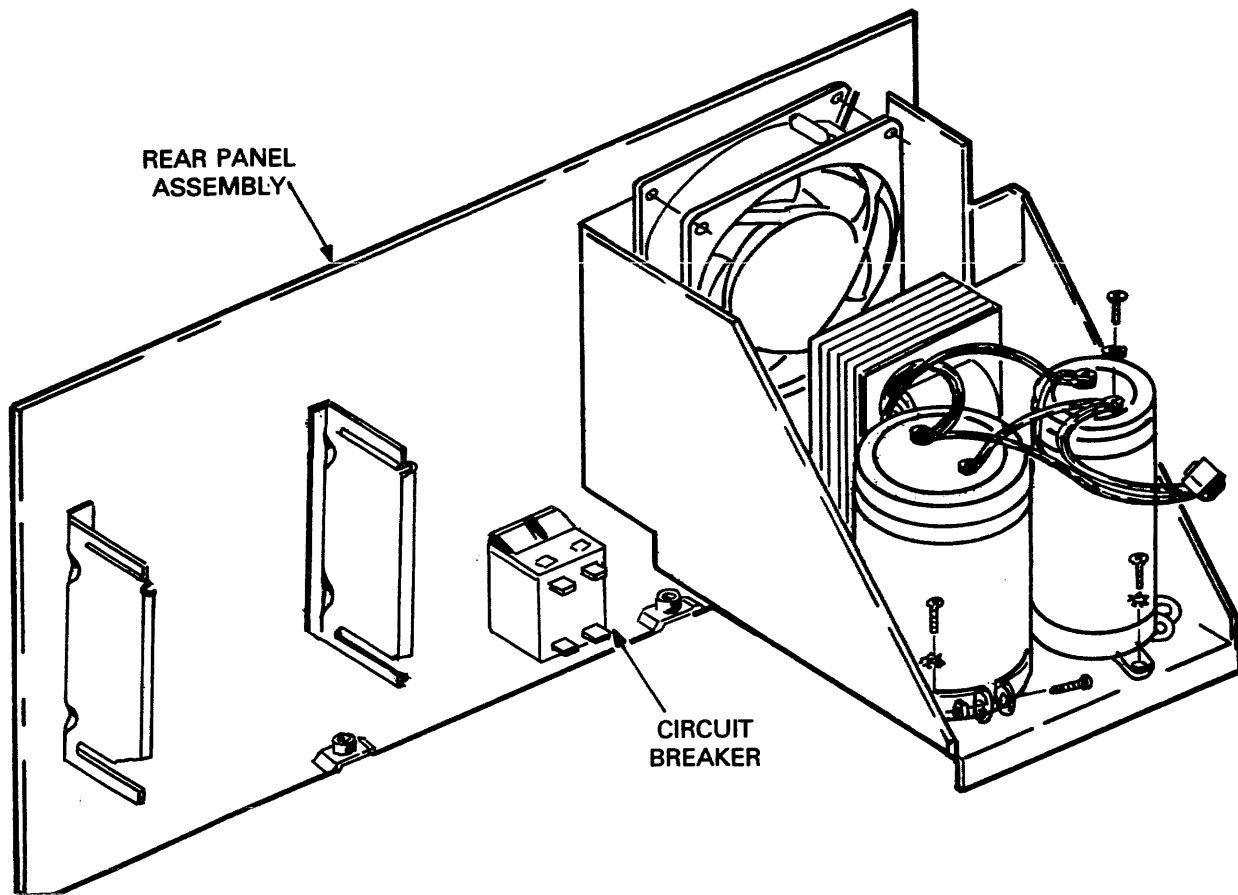

CZ-0017

Figure 2-27 Circuit Breaker

To replace the circuit breaker:

1. Slide the breaker into the power supply panel, ensuring that the "OFF" position is down.
2. Reconnect the wires going to the breaker, as marked when removed.
3. Reinstall the power supply panel (Paragraph 2.8.1).

### 2.8.5 Spindle Drive Motor

To remove the spindle drive motor:

1. Remove the power supply (Paragraph 2.8.1).
2. Remove the drive motor tension spring from the motor housing (Figure 2-25).
3. Remove the two drive motor mounting screws from the standoffs (Figure 2-28).

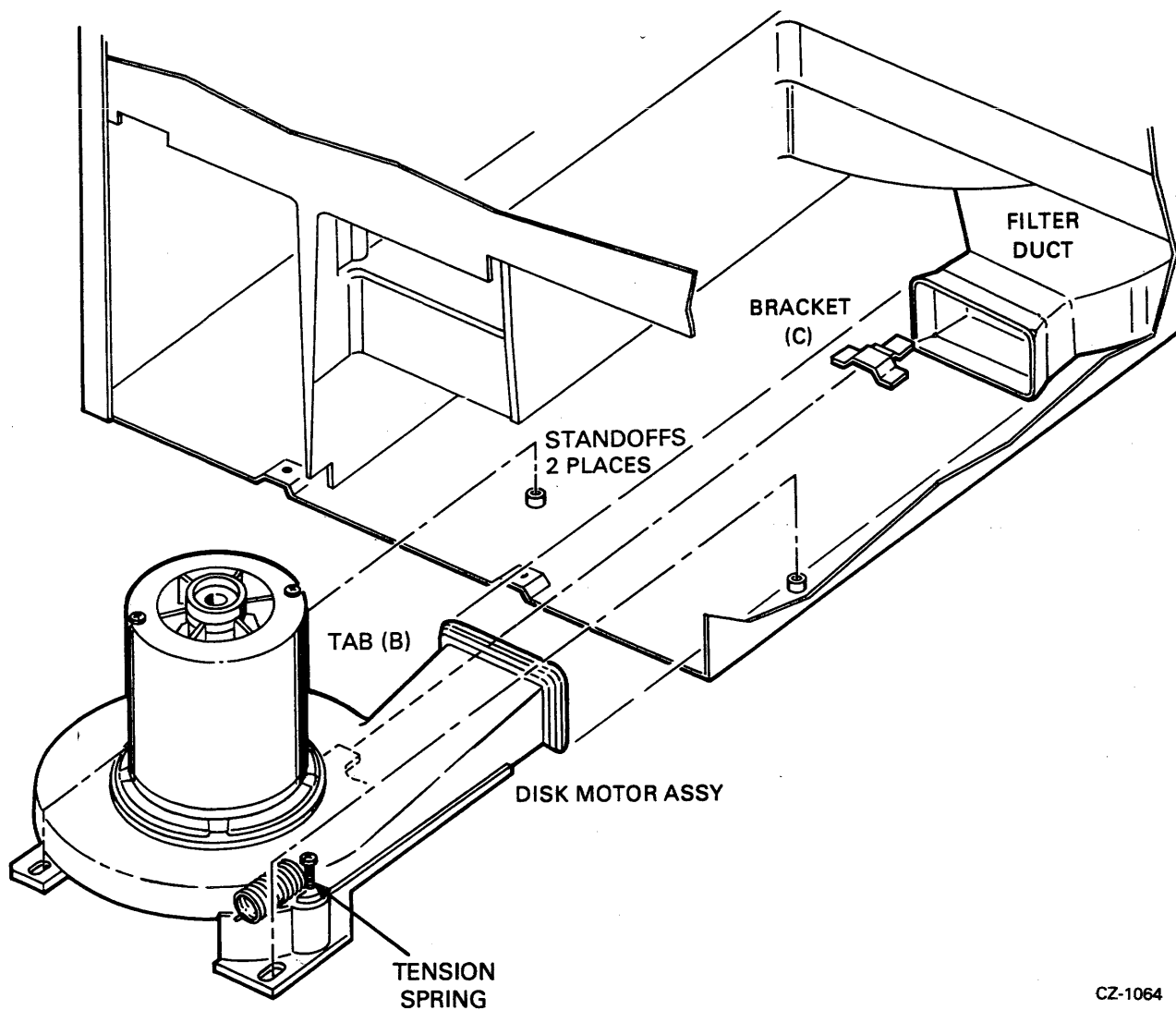

CZ-1064

Figure 2-28 Drive Motor Assembly Technique

4. Slide the drive motor housing forward slightly and lift the assembly up approximately one-half inch.
5. Drive belt should have fallen off; if not, remove it.
6. Slide drive motor out of the drive.

To replace the spindle drive motor:

1. Check to see if the drive belt is still on the spindle pulley. If not, replace it.
2. From the back of the drive, pull on the belt to take away the slack.
3. Slip the belt onto the drive motor pulley.
4. Using Figure 2-28, reinstall drive motor into the rear of the drive. Note the items listed below.
  - Tab (B) fits under bracket (C)
  - Blower housing mounting pads fit over the standoffs
  - Delrin spacers are still on the standoffs
5. Check that belt did not come off the motor pulley.
6. If the belt is still on, check to see if it came off the spindle pulley. If belt is off, replace on the pulley.
7. Attach the drive motor tension spring to the motor housing (Figure 2-25).
8. Install mounting hardware on drive motor housing, using Figure 2-25 as a guide.
9. Pull backward on the drive motor housing to apply tension to the belt. Tension spring should hold motor in place.
10. Rotate spindle several times to position belt on the crowned self-centering pulleys.
11. The belt should have proper tension as applied by the tension spring. Figure 2-26 illustrates proper belt tension.
12. Reinstall the power supply panel (Paragraph 2.8.1).

# CHAPTER 3

## CHECKS, ADJUSTMENTS AND ALIGNMENTS

### 3.1 INTRODUCTION

Many of the checks, adjustments and alignments described in this chapter deal with the drive logic module (DLM). Because there are three different versions of the DLM, it is necessary to first identify the particular type of module on the drive being serviced. The three versions are shown in Figure 3-1.

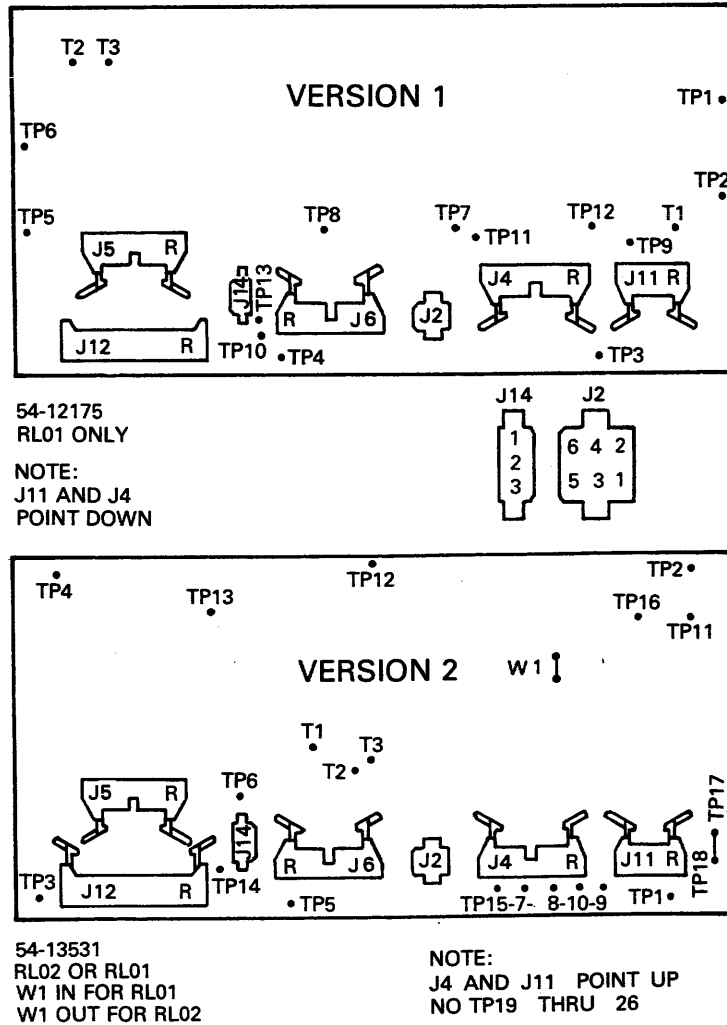
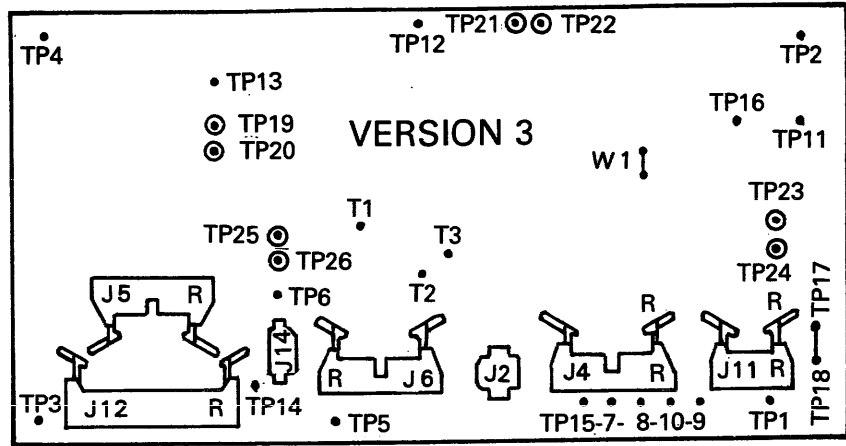

Figure 3-1 Drive Logic Module Layout Sheet 1 of 2



NOTE: R DENOTES RED STRIPE

54-14025  
 RL02 OR RL01  
 W1 IN FOR RL01  
 W1 OUT FOR RL02

NOTE:  
 J4 AND J11 POINT UP  
 HAS TP19 THRU 26

JUMPER	TEST LUGS	EFFECT
19-20	19-20	DEFEAT COVER CLOSED
21-22	21-22	SELECT HEAD 1
23-24	23-24	DISABLE SKTO
25-26	25-26	DEFEAT POS SIG

(THESE TEST LUGS ARE CIRCLED)

NOTE:  
 JUMPER W1 MAY BE FOUND  
 BETWEEN IC LOCATIONS 21 AND  
 25 AS SHOWN

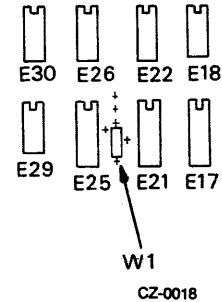

Figure 3-1 Drive Logic Module Layout Sheet 2 of 2

- Version 1 (Part No. 54-12175) can be identified by the fact that the two Berg connectors in the lower right hand portion of the module point down, while the other two along the bottom row point up. This board will only operate in an RL01.
- Version 2 (Part No. 54-13531) has all four connectors in the bottom row pointing up, as in Figure 3-1. This module will function in an RL01 or an RL02.
- Version 3 (Part No. 54-14025) has the same arrangement of Berg connectors as Version 2, but it also has test lugs (shown in Figure 3-1) that are not on either of the other two modules.

The service jumpers used in these checks and adjustments are listed in Table 3-1.

In the course of performing some of the alignments, it is necessary to select head 1 and then later select head 0. The methods for accomplishing this are shown in Table 3-2.

**NOTE**

**If diagnostics are not available, toggle in the appropriate program shown in Appendix C.**

**Table 3-1 Service Jumpers for Drive Logic Module**

<b>Version</b>	<b>Defeat Cover Switch</b>	<b>Defeat POS SIG</b>	<b>Defeat SK TO</b>	<b>Select Head 1</b>
1	E33-3 to E33-7	TP8 to TP1-6	E17-6 to E17-7	-
2	E54-12 to E54-7	TP6 to TP1-4	E10-8 to E10-7	-
3	TP19 to TP20	TP6 to TP Logic Ground (TP1-TP4)	TP23 to TP24	TP21 to TP22

**Table 3-2 Methods for Selecting Heads**

	<b>DLM Version 1 or 2</b>	<b>DLM Version 3</b>
PDP-11	Load DZRLCXX or CZRLIXX and run head alignment routine. WRITE PROTECT switch in = head 1, out = head 0	Jumper TP21 to 22 = head 1 No jumper = head 0
PDP-8	Load AJRLBXX or AJRLHXX and run head alignment routine. WRITE PROTECT switch in = head 1, out = head 0	Same as above

### 3.2 VOLTAGE CHECKS

The dc servo module template indicates voltage test points. Check the following voltages.

Voltage	Limits
+V <sub>un</sub>	+14 V to +18 V
-V <sub>un</sub>	-14 V to -18 V
+5 V	+4.85 V to +5.35 V
+8 V	+7.7 V to +8.3 V
-8 V	-7.7 V to -8.3 V

The regulators on the dc servo module are not adjustable. If a voltage is out of tolerance, the faulty FRU should be replaced.

The +5 V can be killed by a blown pico fuse, a thermal switch on the dc servo heat sink, an overvoltage crowbar, or a home switch on the positioner not being closed during power up.

### 3.3 SECTOR TRANSDUCER OUTPUT CHECK

This check verifies a correct output of the sector transducer.

#### A. Required Tools:

1. Oscilloscope with probe
2. DIP clip.

#### B. Check:

1. Remove both top cover assemblies.
2. Install cartridge.
3. Defeat the cover interlock (Table 3-1).
4. Depress LOAD switch.
5. While waiting for the heads to load onto the pack, set up the oscilloscope (sync internal negative-going).
- 6a. DLM Version 1: Place oscilloscope probe on E8, pin 8.
- 6b. DLM Version 2: Place oscilloscope probe on TP14.
- 6c. DLM Version 3: Place oscilloscope probe on TP14.
7. The signal displayed on the oscilloscope should be similar to that shown in Figure 3-2. The peak output of the negative portion of the waveform should be between 0.35Vp and 1.5 Vp.

#### NOTE

The waveform must be negative-going first.

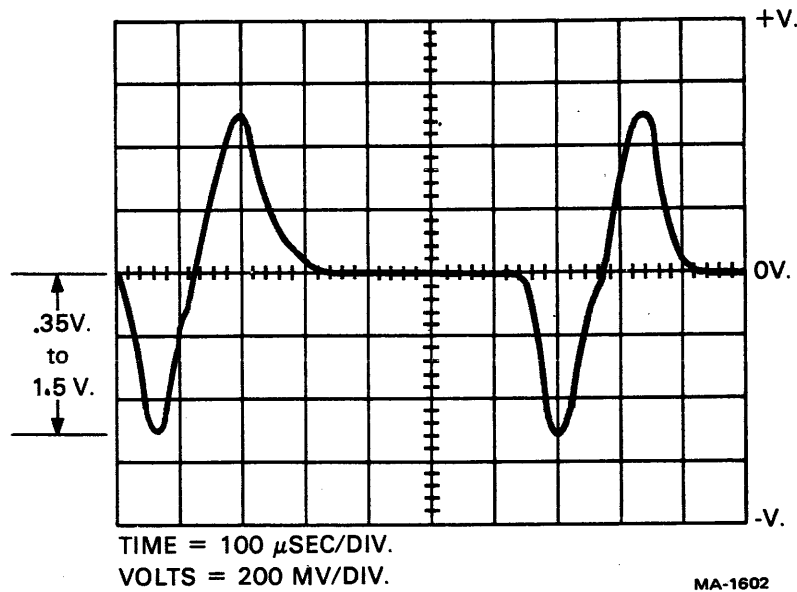

Figure 3-2 Sector Transducer Output

### 3.4 SECTOR PULSE TIMING CHECK

This is a check of the sector pulse width and repetition rate. The repetition rate is a function of spindle speed.

- A. An oscilloscope with probe is required.
- B. Check:
  1. Remove both top cover assemblies.
  2. Defeat cover interlock (Table 3-1).
  3. Install cartridge.
  4. Depress LOAD switch.
  - 5a. Version 1 of DLM: Place the probe on TP9.
  - 5b. Version 2 of DLM: Place the probe on TP11.
  - 5c. Version 3 of DLM: Place the probe on TP11.
  6. Set the oscilloscope to sync internal, negative-going. The signal displayed on the oscilloscope should be the same as in Figure 3-3. Sector pulse width should be 62.5 microseconds. Correct disk speed ranges from 594 microseconds to 639 microseconds, with 624 being the desired norm. The sector pulses should be stable at some time period within that range.



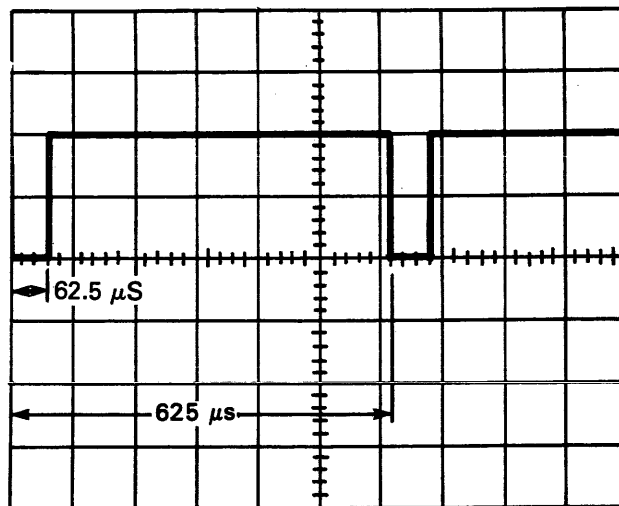

TIME = 100  $\mu$ s/DIV.  
 VOLTS = 2V/DIV.

CZ-1078

Figure 3-3 Sector Pulse Timing

### 3.5 READ SIGNAL AMPLITUDE ADJUSTMENT

This check compares the amplitudes of the read signal from each read/write head against the data in the engineering specification.

#### A. Required Tools:

1. Oscilloscope with two probes
- 2a. One DIP clip, one pin-to-pin jumper and one test lead (alligator clip), or
- 2b. Two pin-to-pin jumpers and two DIP clips
3. Diagnostic listed in Table 3-2.

#### B. Check:

1. Remove both top cover assemblies.
2. Defeat SKTO, POS SIG and cover interlock (Table 3-1).
3. Place the read/write module box assembly up and out of the way on the carriage assembly (Figure 3-4).
4. Install cartridge.
5. Depress the LOAD switch.
6. Wait for the heads to load.
7. Disable the servo drive to the carriage by disconnecting the in-line connector.

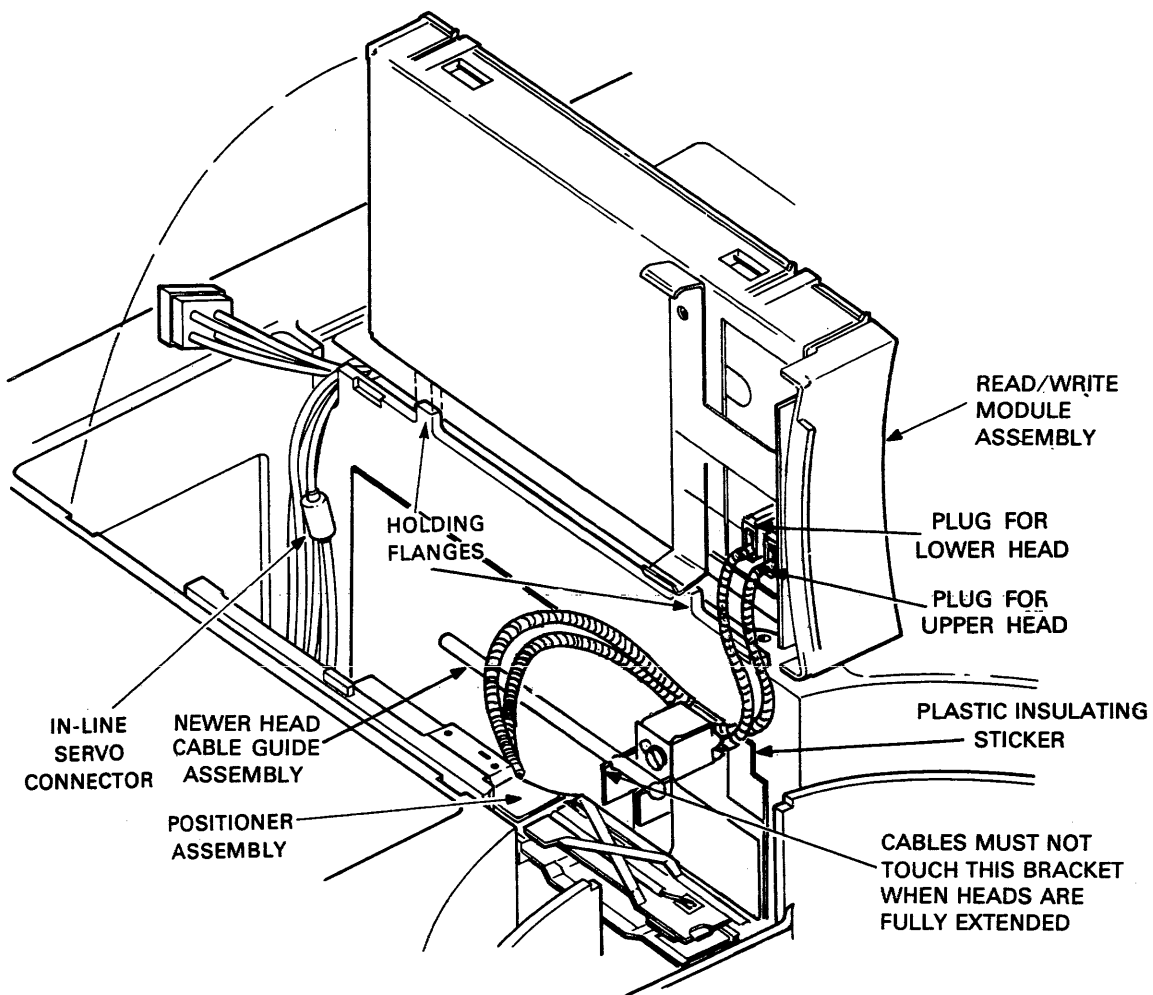

CZ-0136

Figure 3-4 Positioner and Read/Write Module Box Assembly

- 8a. Version 1 of DLM: Place Channel A probe on TP9 (Sector Time).
- 8b. Version 2 of DLM: Place Channel A probe on TP11 (Sector Time).
- 8c. Version 3 of DLM: Place Channel A probe on TP11 (Sector Time).
9. Place the Channel B oscilloscope probe on TP2 of the read/write module (Servo Data).
10. Set the oscilloscope to sync internal on Channel A, negative-going, and observe the waveform shown in Figure 3-5.
11. Move the positioner forward until the S1 servo burst loses amplitude and finally disappears. This is the inner guard band area of the disk.

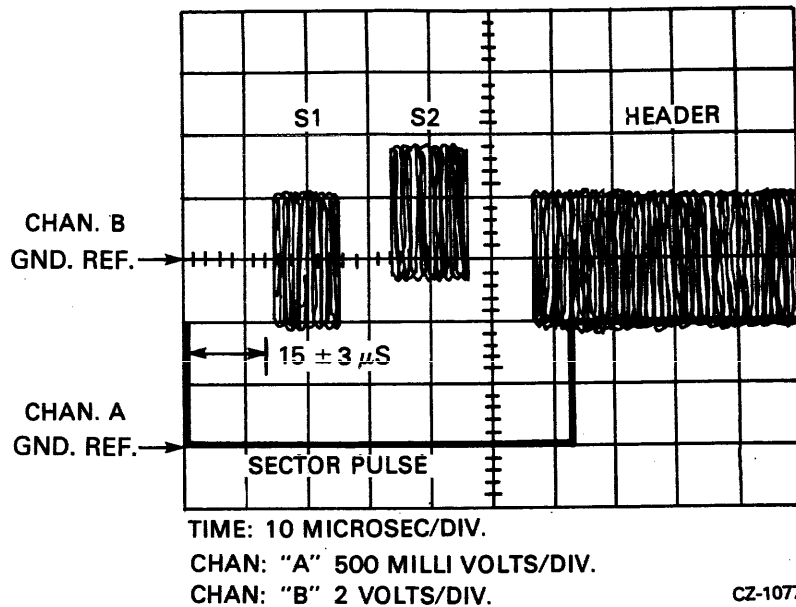

Figure 3-5 Servo Bursts and Sector Pulse

12. Pull the positioner back slowly until the S1 servo burst returns.
13. Move the positioner slowly in *small* amounts to obtain a maximum amplitude from the S1 servo burst. At this point the positioner is at the last data track on the disk.
14. Measure and record the peak-to-peak amplitude of the S1 burst for both heads. See Table 3-2 to select the heads.
15. Adjust the lower of the two amplitudes to 650 millivolts, by rotating the appropriate potentiometer on the read/write module.

**NOTE**

**On the newer read/write modules, jumper W1 is in when mounted in an RL01 drive. This requires that potentiometer R41 be adjusted. For RL02 drives, jumper W2 is in and requires that potentiometer R40 be adjusted see Figure 3-6.**

16. Select the opposite head. The maximum allowable amplitude should be no greater than 850 millivolts.
17. If the selected head amplitude is greater than 850 millivolts, then replace the upper head (0). If the two read/write heads are within specification, then continue with the next step. If a head was replaced, go back to step 4.
18. Reposition the carriage to track 0 by moving the positioner toward the rear of the drive until the S2 servo bursts disappear. This is the outer guard band area of the disk.
19. Pull the positioner back slowly until the S2 servo burst returns.

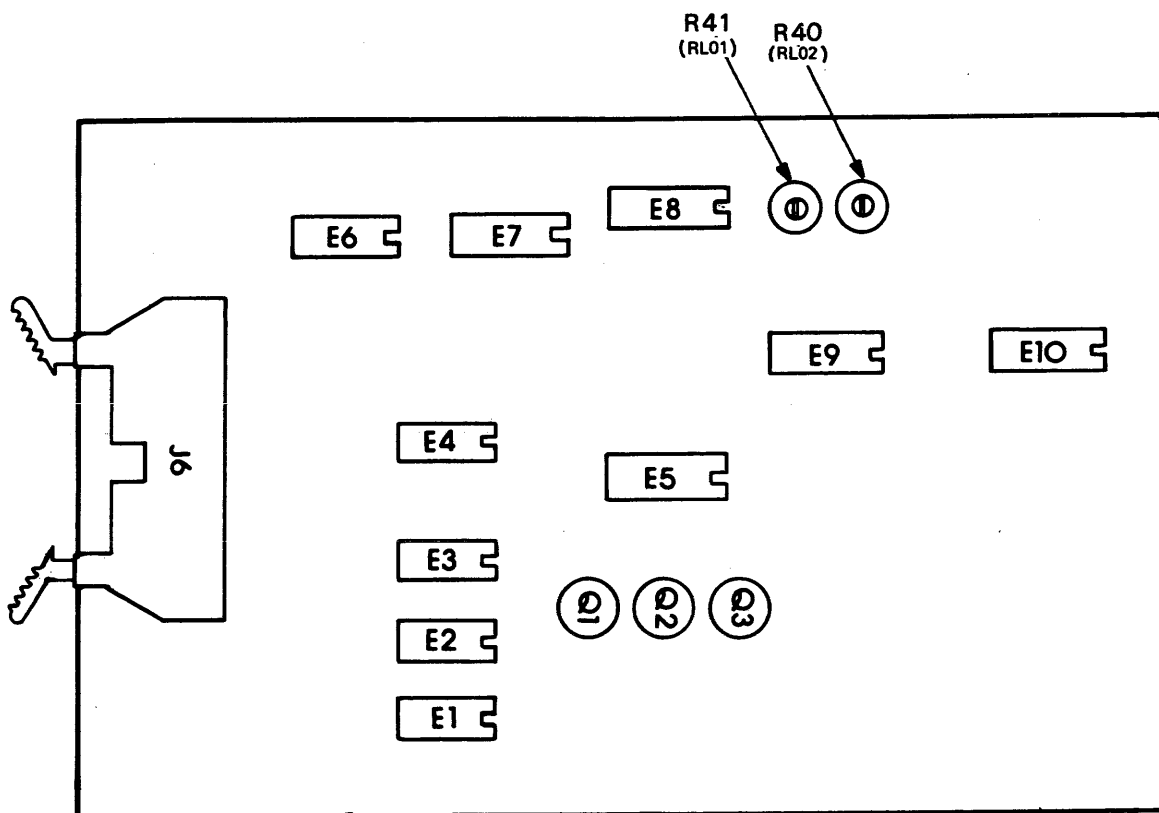

CZ-0729

Figure 3-6 Amplitude Adjustment POT Locations

20. Move the positioner slowly in small amounts to obtain a maximum amplitude from the S1 servo burst. At this point the positioner is at track 0.
21. Measure and record the peak-to-peak amplitude of S1 for both heads. See Table 3-2 to select the heads. The maximum allowable amplitude of the S1 servo burst while on track 0 is 2.25 V.
22. If the specification cannot be met, replace the cartridge and re-run the check from step 5. If the original cartridge was causing the amplitude specification to fail, the new cartridge will allow the amplitude to pass specification.
23. If after replacing the original cartridge with a new cartridge, the amplitude specification still fails, replace the read/write heads one at a time. This procedure should be run from step 4 each time to check the amplitude specification.

#### **NOTE**

**If both heads fail to meet the specification, it is possible that the read/write module is bad. Replace the module (see Chapter 2) and repeat the procedure. If a head is replaced, it must be aligned (see Paragraph 3.7). The radial alignment must also be checked (Paragraph 3.6).**

### **3.6 POSITIONER RADIAL ALIGNMENT**

This adjustment assures that the servo burst (as read by the read/write heads) occurs in the proper time relation to the sector pulses from the cartridge hub. It also enables the technician to observe how straight the carriage motion is over the length of travel, and also acts as a check for head skew.

#### **A. Tools Required:**

1. Oscilloscope with two probes
2. Two flat-blade screwdrivers
3. One Phillips head screwdriver
- 4a. One DIP clip, one pin-to-pin jumper and one test lead, or
- 4b. Two pin-to-pin jumpers and two DIP clips
5. Diagnostic listed in Table 3-2.

#### **B. Positioner Alignment Check:**

1. Remove both top cover assemblies.
2. Defeat POS SIG, SKTO and cover interlock (Table 3-1).
3. Place the read/write module box assembly up and out of the way of the carriage assembly.
4. Install cartridge.

5. Depress LOAD switch.
6. Wait for heads to load onto the pack.
7. Disable servo drive to the carriage by disconnecting the in-line connector (Figure 3-4).
8. Select head 1 (Table 3-2).
9. Place the Channel B oscilloscope probe on TP2 (data) of the read/write module and Channel B ground on TP3.
- 10a. DLM Version 1: Place Channel A probe on TP9 (SEC TIME) and Channel A ground on any signal ground (TP1-TP4).
- 10b. DLM Version 2: Place Channel A probe on TP11 (SEC TIME) and Channel A ground on any signal ground (TP1-TP4).
- 10c. DLM Version 3: Place Channel A probe on TP11 (SEC TIME) and Channel A ground on any signal ground (TP1-TP4).
11. Set the oscilloscope to sync internal, negative-going on Channel A and observe the waveform shown in Figure 3-5.

**NOTE**

**S1 and S2 servo bursts may not appear in the positive/negative proportions shown in Figure 3-5, depending upon which track the head is centered on.**

12. Measure the time between the negative-going edge of the sector pulse and the beginning of the S1 servo burst when the positioner is at cylinder 0. Record this value.
13. Select head 0 (Table 3-2).
14. Repeat Step 12 for head 0. Record this value.
15. If the difference between these two values is greater than six microseconds, replace head 0 (see Chapter 2) and go back to Step 14. If either of the two values falls outside of the  $15 \pm 3$  microsecond specification, perform the alignment procedure (Part C below). Otherwise, continue.
16. Manually move the carriage to the last data track (track 255 on an RL01 or track 511 on an RL02). As head 0 enters the inner guard band, S1 disappears. Move the positioner back until S1 appears.
17. Measure the time between the negative-going edge of the sector pulse and the beginning of the S1 servo burst when the positioner is at the last cylinder. It should be  $15 \pm 3$  microseconds. If so, the check is complete. Otherwise perform the adjustment (Part C) below.

### C. Positioner Alignment

1. Using Figure 3-7 as a guide, locate the six largest Phillips screws on the positioner base-plate.
2. Loosen (but do not remove) the six screws holding down the positioner.
3. Take the two flat-blade screwdrivers and insert them into the adjusting slots on the positioner.
4. Move the positioner assembly against the right hand side of the drive (toward the read/write module).
5. Manually move the carriage to its approximate center of travel.
6. Using the two flat-blade screwdrivers in the adjusting slots, slide the positioner base-plate until the  $15 \pm 3$  microsecond specification between the fall of the sector pulse and the rise of the S1 servo burst can be met. (See Figure 3-5.)

#### **NOTE**

**Equal pressure must be exerted on the screwdrivers when sliding the positioner to ensure that the base-plate is kept straight.**

**If positioner resists movement, remove sector transducer cable from positioner. Don't forget to replace it when adjustment is complete.**

7. Tighten the six retaining screws in small increments.
8. Check the  $15 \pm 3$  microseconds specification for head 0 at track 0 and the last track. If the head is within the specification, the check is complete. Otherwise, repeat the adjustment (Part C) above.

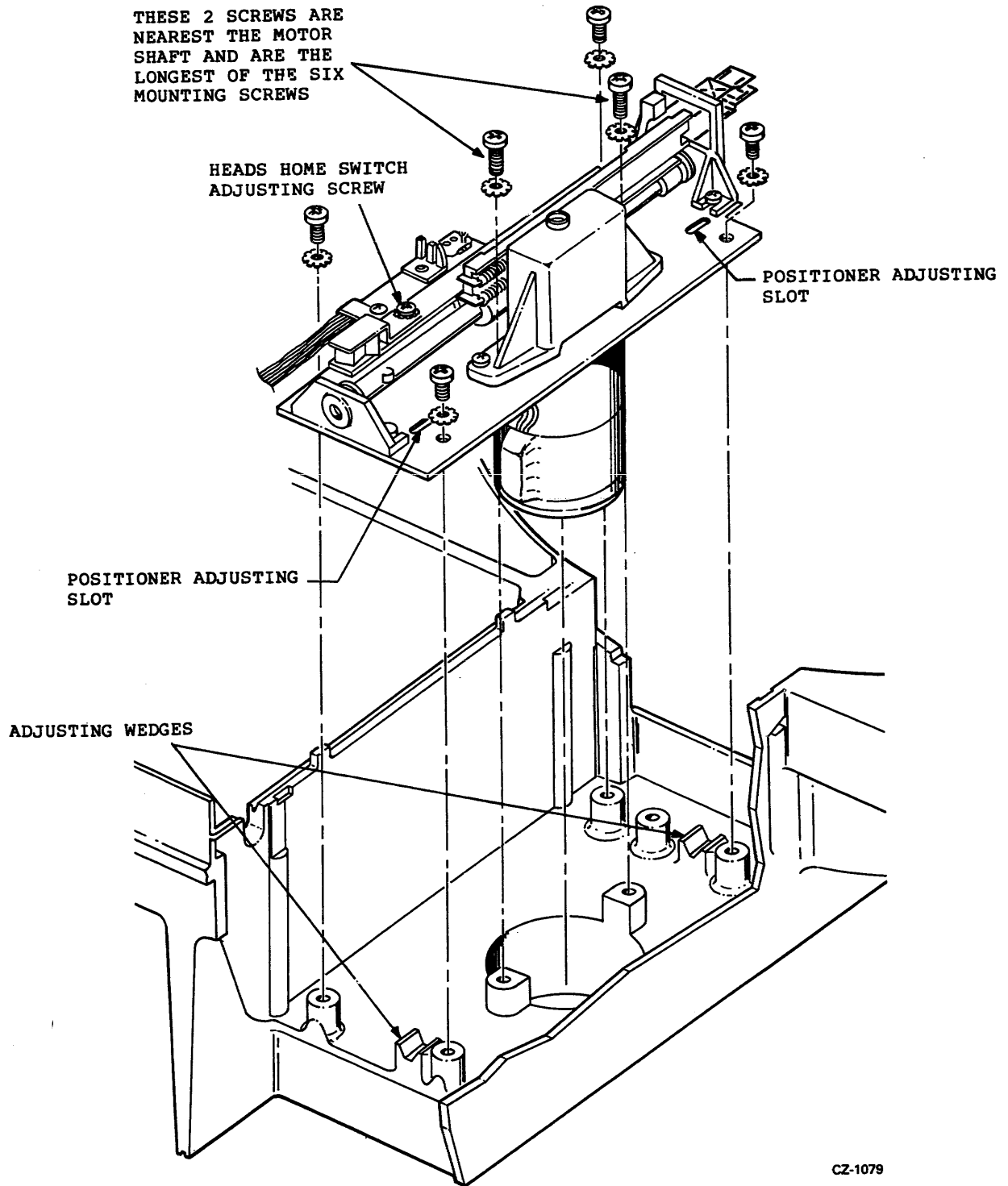

Figure 3-7 Positioner Assembly



### 3.7 HEAD ALIGNMENT

This procedure will ensure that the two heads are in line with each other to cut down on the servo tracking time when switching heads.

#### NOTE

**The Read Signal Gain Adjustment (Paragraph 3.5) and the Positioner Radial Alignment (Paragraph 3.6) should be performed before attempting Head Alignment.**

#### A. Required Tools:

1. Oscilloscope with one probe
2. 3/32" Allen wrench
3. Flat-blade screwdriver
- 4a. One DIP clip, one pin-to-pin jumper and one test lead (alligator clip), or
- 4b. Two pin-to-pin jumpers and two DIP clips
5. Diagnostic listed in Table 3-2.

#### NOTE

**No alignment cartridge is required.**

#### B. Alignment Check:

1. Remove both top cover assemblies.
2. Defeat SKTO and POS SIG (Table 3-1).

#### NOTE

**These jumpers enable the diagnostic routine to work by disabling the Seek Timeout Error.**

3. Defeat cover interlock (Table 3-1).
4. Place the read/write module box assembly up and out of the way of the carriage assembly.
5. Install cartridge.
6. Depress the LOAD switch.
7. Wait for the heads to load onto the pack.
8. Disable servo drive to the carriage by disconnecting the servo in-line connector (Figure 3-4).
9. Select head 1 (Table 3-2).

10. Place the Channel A oscilloscope probe on one of the following test points.

- DLM version 1: E11 pin 7
- DLM versions 2 and 3: TP15

The probe ground lead should be on a test point ground of the DLM (TP1-TP4).

Set the vertical gain to 1 volt per division. Set oscilloscope horizontal circuit to free run (unsynched). The horizontal sweep rate is not important.

11. Manually move the positioner back to the head loading ramp and then forward toward the center of the disk while watching the READY indicator and the oscilloscope presentation of the position signal. These two indicate the position of the head relative to the tracks written on the surface.

When the head is over the head loading zone (outside the outer guard band) the position signal floats slowly toward +8 V and the READY indicator is on. When the head is over the outer guard band the position signal is at a maximum negative voltage (about -1.5 V) and the READY indicator is off. As the head approaches cylinder 0, the position signal starts to move up toward 0 V and the READY indicator turns on.

As the positioner continues to move forward, the READY Indicator remains on and the position signal is 0 V when the head is directly over the center of cylinder 0. The position signal continues to move in the positive direction as the head passes cylinder 0 and reaches its maximum normal value of about +1.5 V as the head is halfway between cylinder 0 and cylinder 1. The position signal then starts to move down as cylinder 1 is approached and is at 0 V when the head is over cylinder 1. If cylinder 1 is overshot, the position signal goes negative, then back to 0 V over cylinder 2, and so on.

By observing the oscilloscope and READY indicator, it is possible to locate cylinder 0 by moving the positioner into the outer guard band (position signal is negative and the READY indicator is off), and then moving the positioner forward to cylinder 0 (position signal rises to 0 V and the READY indicator turns on). The verification process is to move the positioner in reverse and observe the the position signal go negative as the READY indicator goes off and see the position signal stay negative as the head moves over the outer guard band.

12. Position head 1 directly over cylinder 0.
13. Hold the positioner still and select head 0.
14. If the position signal is within 0.5 V of 0 V, then verify that head 0 is over cylinder 0. If both of these criteria are met, the head alignment is satisfactory. Be sure to reconnect the in-line servo connector before unloading the heads. The head alignment check is complete. Go on to the next check.

If either of these criteria is not met, go to Step 15.

15. If the position signal was not within 0.5 V of ground or head 0 was over a cylinder other than 0, perform the head alignment procedure as outlined in paragraph C that follows.

### C. Head Alignment Procedure

1. Move the positioner all the way back to the home position so that the heads are up on the ramp. Loosen the mounting screw for head 0 and move head 0 all the way back to its extreme position against the stop.
2. Select head 1.
3. Move the positioner so that head 1 is directly over cylinder 0.
4. Select head 0.
5. Hold the positioner still while sliding head 0 forward by twisting a screwdriver between the end of the head assembly and the stop. Observe the READY indicator and the position signal and move head 0 until it is over cylinder 0.
6. Select head 1.
7. Verify that head 1 position signal is within 0.5 V of 0 V and that head 1 is still over cylinder 0. If these two criteria are not met, repeat the procedure.
8. Snug the mounting screw for head 0 while the heads are over the surface. Move the positioner to its home position before tightening the mounting screw. Do not overtighten the screw.

#### **NOTE**

**If the retaining screw is overtightened, the threads on the aluminum frame may be damaged.**

9. Verify that tightening the mounting screw did not change the alignment enough to make it unsatisfactory. To do this, select head 1, move it over cylinder 0, select head 0, and verify that it too is over cylinder 0 and within 0.5 V. If these specifications cannot be met, repeat the procedure. Otherwise, continue with Step 10.
10. If the head cable clips are on the read/write module box, replace the head cables in the clips, and go to Step 14.
11. Manually move the heads toward the spindle, as far as they will go.
12. Mount the head cables into the clips on the cable guide. The cable for the lower head should go into the lower clip.
13. Ensure that the cables do not touch the corner of the cable guide bracket (as shown in Figure 3-4). If they do, readjust the cables in the clips so that they do not touch the corner of the bracket.

#### **NOTE**

**The positioner MUST be fully extended when performing this check.**

#### NOTE

The read/write module box assembly will have to be removed from the baseplate holding flanges and held in one hand to readjust the cables, as the cables are not long enough to reach.

14. Replace the servo in-line connector to unload the heads. At this point, the procedure is finished.

### 3.8 SPINDLE RUNOUT CHECK

Excessive runout in the spindle assembly or cartridge can cause severe tracking problems for the positioning system. This check will determine whether:

1. Runout exists or does not exist
2. Runout is in the cartridge
3. Runout is in the spindle.

#### A. Required Tools:

1. Oscilloscope with probe and ground leads
2. DIP clip
3. Jumper
4. Several test cartridges

#### B. Runout Check:

1. Remove both top cover assemblies.
2. Place the read/write module box assembly up and out of the way of the carriage assembly.
3. Defeat cover interlock (Table 3-1).
4. Install cartridge.
5. Depress LOAD switch.
6. Wait for heads to load onto the pack.
7. Disable servo drive to the carriage by disconnecting the in-line connector (Figure 3-4).
- 8a. DLM Version 1: Place Channel A oscilloscope probe on E11 pin 7 (Position Signal) and place Channel A ground on TP7 (Integrator Ground).
- 8b. DLM Version 2: Place Channel A oscilloscope probe on TP15 (Position Signal) and place Channel A ground on TP5 (Integrator Ground).
- 8c. DLM Version 3: Place Channel A oscilloscope probe on TP15 (Position Signal) and place Channel A ground on TP5 (Integrator Ground).
9. Set the oscilloscope to sync internal, negative-going and observe the position signal waveform shown in Figure 3-8.

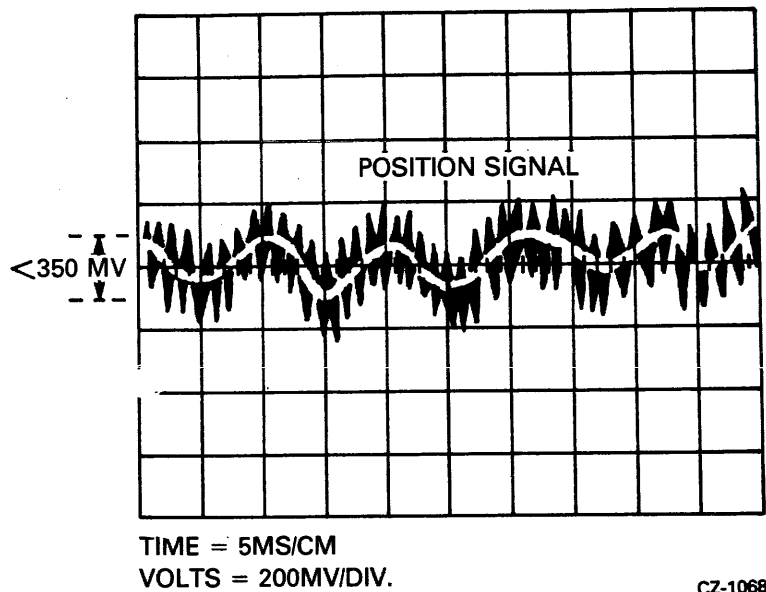

Figure 3-8 Position Signal

10. The amplitude of the runout should be no greater than 350 millivolts.
11. If the specification cannot be met, runout exists and another cartridge is needed to determine if the runout exists in the cartridge or the spindle.
12. To confirm a seating problem, re-seat the cartridge and repeat the runout check. If the runout is within specification, the problem has been solved. If the runout is still out of specification, continue with Step 13.
13. Spindle and cartridge are still suspect, so install a second cartridge and repeat check. If runout is now within the specification, the first cartridge is bad. If the runout check fails once more, assume that the spindle bearings are bad and replace the spindle assembly.

### 3.9 POSITION SIGNAL GAIN CHECK

Insufficient amplitude of the position signal could result in the carriage not being able to hold itself on track, resulting in read errors and possible seek errors. Too high an amplitude could result in a jitter which, in turn, emits a vibrating-type noise from the carriage that may generate seek timeout errors.

#### A. Required Tools:

1. Oscilloscope with probe and ground leads
2. One DIP clip, one pin-to-pin jumper.

#### B. Gain Check:

1. Remove both top cover assemblies.
2. Place the read/write module box assembly up and out of the way of the carriage assembly.

3. Defeat cover interlock (Table 3-1).
4. Install cartridge.
5. Depress LOAD switch.
6. Wait for heads to load onto the pack.
7. Disable servo drive to the carriage by disconnecting the in-line connector (Figure 3-4).
- 8a. DLM Version 1: Place Channel A oscilloscope probe on E11 pin 7 (Position Signal) and place Channel A ground on TP7 (Integrator Ground).
- 8b. DLM Version 2: Place Channel A oscilloscope probe on TP15 (Position Signal) and place Channel A ground on TP5 (Integrator Ground).
- 8c. DLM Version 3: Place Channel A oscilloscope probe on TP15 (Position Signal) and place Channel A ground on TP5 (Integrator Ground).
9. Observe the position signal gain waveform as shown in Figure 3-9(a) while manually moving the carriage back and forth.

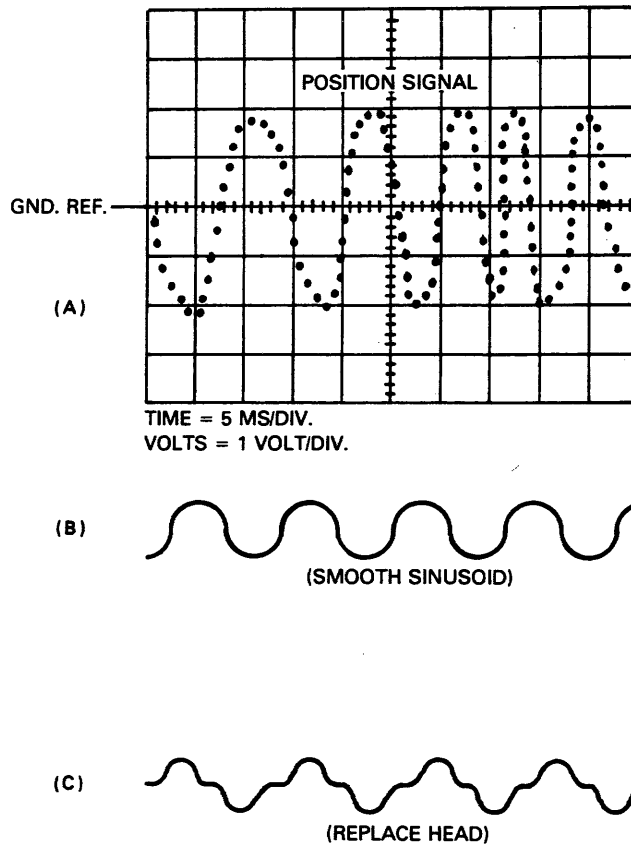

CZ-1069

Figure 3-9 Position Signal Gain Check Waveforms

10. Measure the peak-to-peak deviation of the position signal amplitude about the ground reference. It should be  $3.7 \pm 0.7$  volts.

**NOTE**

1. If these amplitudes are not within tolerance, the head load operation would most likely fault.
  2. Look at the servo data waveforms at TP2 of the read/write module for a smooth sinusoidal waveform, as in Figure 3-9(b). If something like Figure 3-9(c) is seen, the head azimuth angle is wrong. In this case, replace the read/write head.
  3. If the head azimuth is good, then check to see if the  $\pm 8$  Vdc voltages are out of tolerance (Paragraph 3.2).
11. Repeat procedure for other read/write head.

### **3.10 TACHOMETER AC NOISE PICK-UP CHECK**

This procedure checks the amount of noise being picked up by the tachometer. If the noise is excessive, the positioner will have a hard time holding onto a track signal. In this case, the READY light may flicker.

**A. Required Tools:**

1. Oscilloscope with probe and ground leads
2. DIP clip
3. Jumper.

**B. Check:**

1. Remove both top cover assemblies.
2. Place the read/write module up and out of the way of the carriage assembly.
3. Defeat cover interlock (Table 3-1).
4. Install cartridge.
5. Depress LOAD switch.
6. Wait for heads to load onto the pack.
7. Disable servo drive to the carriage by disconnecting the in-line connector (Figure 3-4).
8. Set the oscilloscope (sync internally) as follows:
  - a. Channel A probe should be on TP1 of the dc servo module (summing amp).
  - b. Channel A ground should be on TP11 of the dc servo module (signal ground).

9. Each drive's summing amplifier output at this point will look slightly different, but it should be similar to the waveform shown in Figure 3-10.

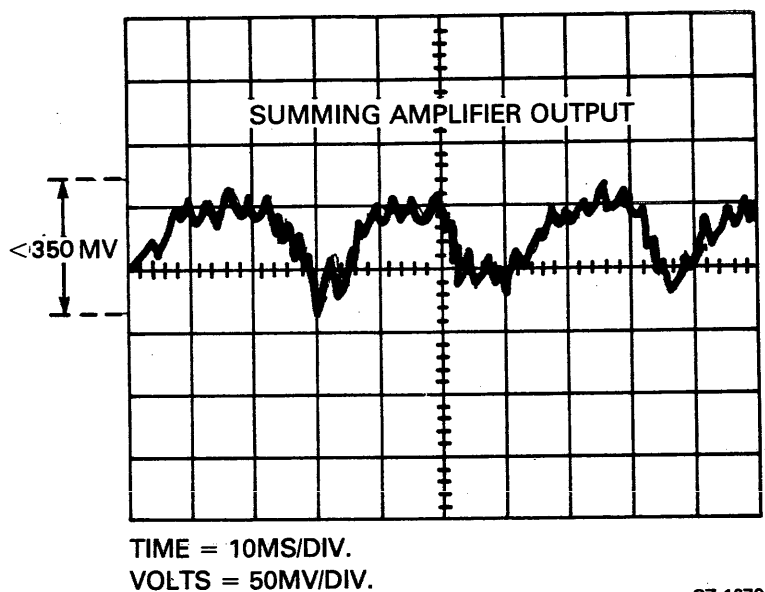

CZ-1070

Figure 3-10 Summing Amplifier Output

10. The signal seen should have a peak-to-peak value of no more than 350 millivolts.
11. If the signal is out of tolerance, the dc servo module could be bad or the drive motor may be too noisy. Replace the module, and if that does not solve the problem, replace the drive motor (see Chapter 2).

### 3.11 VELOCITY PROFILE CHECK

By causing the positioner to perform an oscillating seek, the velocity profile can be checked for duration, amplitude and waveshape.

#### A. Required Tools:

1. Oscilloscope with probe and ground leads
2. Toggle-in oscillating seek program (Appendix C)
3. DIP clip
4. Jumper.

#### B. Check:

1. Remove both top cover assemblies.
2. Install cartridge.
3. Defeat top cover interlock (Table 3-1).
4. Depress LOAD switch.



5. Wait for heads to load onto the pack.
6. Using the oscillating program shown in Appendix C, cause an oscillating seek from track 0 to track 255 (RL01) or track 511 (RL02).
- 7a. Version 1 of DLM: Place the Channel A oscilloscope probe on TP12, place the Channel A ground on any of the DLM ground points (TP1 through TP6 are ground) and place the external trigger on E38 pin 12 (SIGN FWD).
- 7b. Version 2 of DLM: Place the Channel A oscilloscope probe on TP8, place Channel A ground on any of the DLM ground test points (TP1 through TP4 are ground) and place the external trigger on E25 pin 12 (SIGN FWD).
- 7c. Version 3 of DLM: Place the Channel A oscilloscope probe on TP8, place the Channel A ground on any of the DLM ground points (TP1 through TP4 are ground) and place the external trigger on E25 pin 12 (SIGN FWD).
8. Set the oscilloscope to sync internal, positive-going and observe the tachometer output waveform as shown in Figure 3-11.

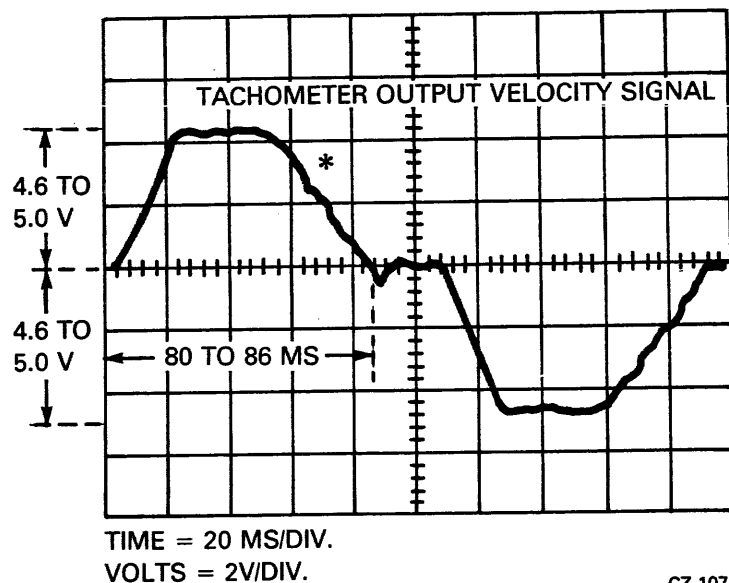

CZ-1071

Figure 3-11 Tachometer Output Velocity Signal

9. The peak amplitude of the waveform should be between 4.6 and 5.0 volts.
10. The maximum seek time should be between 80 and 86 milliseconds.
11. Observe the trailing edge of the waveform (as indicated by an asterisk in Figure 3-11). There should be a slight "stepping" slope. If the observed slope has spikes in it, the positioner needs replacing as it is not rolling smoothly.
12. If the other specifications (in Steps 9 and 10) cannot be met, the dc servo module is probably at fault.

### 3.12 SERVO DRIVE MOTOR CURRENT CHECK

One possible cause of seek errors is excessive drive motor current. This check will determine if there is too much current.

#### A. Required Tools:

1. Oscilloscope with probes and ground leads
2. Toggle in oscillating seek program (Appendix C)
3. DIP clip
4. Jumper.

#### B. Check:

1. Remove both top cover assemblies.
2. Defeat top cover interlock (Table 3-1).
3. Install cartridge.
4. Depress LOAD switch.
5. Wait for heads to load onto the pack.
6. Using the oscillating seek program listed in Appendix C, cause an oscillating seek from track 0 to track 255 (RL01) or track 511 (RL02).
7. Place Channel A oscilloscope probe on TP3 of the dc servo module.
- 8a. DLM Version 1: Place the external trigger on E38 pin 12 (SIGN FWD).
- 8b. DLM Version 2: Place the external trigger on E25 pin 12 (SIGN FWD).
- 8c. DLM Version 3: Place the external trigger on E25 pin 12 (SIGN FWD).
9. Observe the motor current waveform as shown in Figure 3-12.
10. Measure the points called out in the figure and compare them to the following:  
#1 should be between 750 and 780 mv.  
#2 and #3 are the midpoints of the waveform and should be less than or equal to 500 mv.
11. Failure to meet specifications requires replacement of the positioner/drive motor assembly (described in Chapter 2).

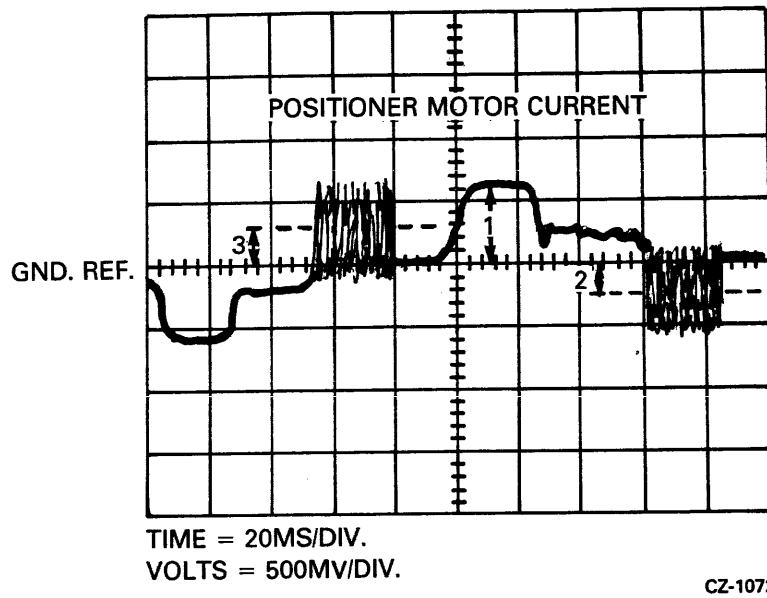

Figure 3-12 Positioner Motor Current Check

### 3.13 ACCESS TIME CHECK

The access time is checked by performing oscillating seeks and observing the position signal and “ready to read/write”.

#### A. Required Tools:

1. Oscilloscope with probes and ground leads
2. Toggle-in oscillating seek program (Appendix C)
3. DIP clip
4. Jumper.

#### B. Check:

1. Remove both top cover assemblies.
2. Defeat the top cover interlock (Table 3-1).
3. Install cartridge.
4. Depress LOAD switch.
5. Wait for heads to load onto the pack.
6. Using the oscillating seek program shown in Appendix C, issue a one track seek.
- 7a. Version 1 of DLM: Place Channel A oscilloscope probe on E25 pin 12 (ready to read/write).
- 7b. Version 2 of DLM: Place Channel A oscilloscope probe on TP16 (ready to read/write).
- 7c. Version 3 of DLM: Place Channel A oscilloscope probe on TP16 (ready to read/write).

8. Observe the access time waveform as depicted in Figure 3-13.

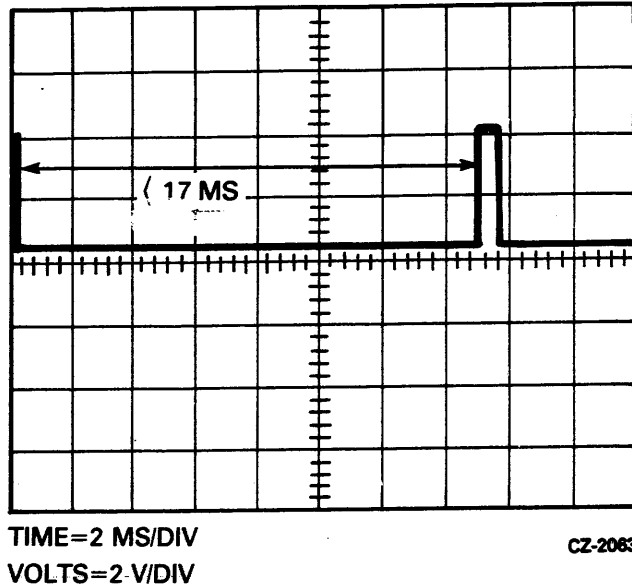

Figure 3-13 Access Time Check (One Track Seek)

9. Measure the time the "ready to read/write" signal is low. It should be less than or equal to 17 milliseconds.
10. Issue a seek from track 0 to track 85 (RL01) or track 170 (RL02) and check to see that "ready to read/write" is low for slightly less than 55 milliseconds. See Figure 3-14.

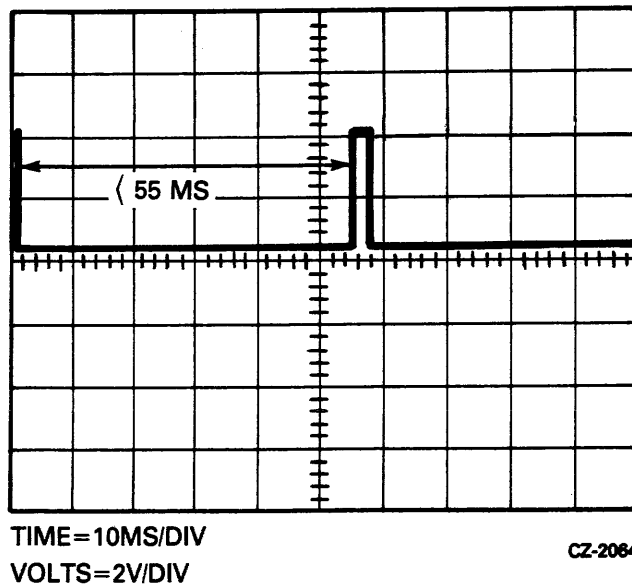
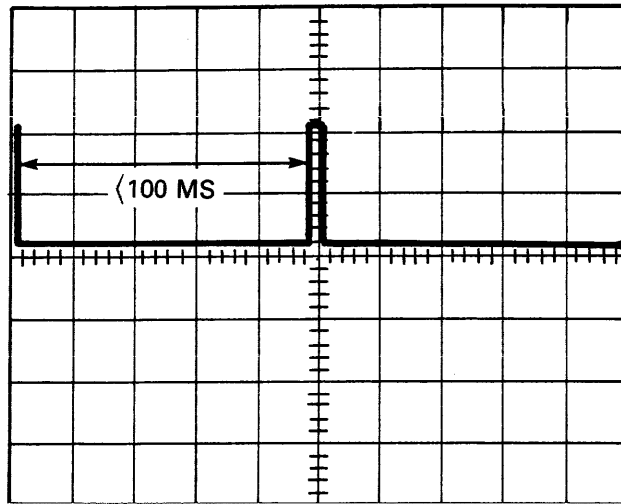

Figure 3-14 Access Time Check (85 Track Seek)

11. Issue a seek from track 0 to track 255 (RL01) or track 511 (RL02) and check to see that "ready to read/write" is low for slightly less than 100 milliseconds. See Figure 3-15.
12. If the specifications are not met, the DLM could be at fault, or the positioner itself may be binding due to excessive friction. (See Paragraph 3-12.)



TIME=20 MS/DIV  
VOLTS=2 V/DIV

CZ-2065

Figure 3-15 Access Time Check (255 Track Seek)

## APPENDIX A REGISTER SUMMARY

### A.1 PROGRAM ACCESSIBLE REGISTERS FOR 11-FAMILY CONTROLLERS

**Table A-1 Subsystem Registers Overview**

Address (octal)	Type (read/write)	Register Name/Mnemonic	Basic Function
774400	R/W	Control Status (CS)	Indicates drive ready condition; decodes drive commands and provides overall control functions and error indications.
774402	R/W	Bus Address (BA)	Indicates memory location involved in data transfer during a normal read or write operation.
774404	R/W	Disk Address (DA)	(1) Holds disk address during a data transfer such as read or write; or (2) holds the drive command word for a seek command; or (3) holds the drive command word for a get status command
774406	R/W	Multipurpose (MP)	(1) Functions as word counter when transferring read/write data between UNIBUS and drives; or (2) acts as storage buffer when reading drive status; or (3) stores header information from controller silo when executing a read header command.
1777410	R/W	Bus Address Extension (BAE)	Contains the upper six bits of the extended bus address for 22-bit addressing (Bits 16:21).

### A.1.1 Register Description

**Table A-2 Control Status Register Bit Description**

CONTROL STATUS REGISTER (CSR)															
15	14	13	12	11	10	09	08	07	06	05	04	03	02	01	00
ERR	DE	E3	E2	E1	E0	DS1	DS0	CRDY	IE	BA17	BA16	F2	F1	F0	DRDY
READ ONLY						READ/WRITE						READ ONLY			

CZ-2009

Bit(s)	Description
--------	-------------

0      **Drive Ready (DRDY)** – When set, this bit indicates that the selected drive is ready to receive a command. The bit is cleared when a seek or head select operation is initiated and set when the operation is completed.

1-3    **Function Code** – These bits are set by software to indicate the command to be executed.

Command	F2-F0
No Op (RL11) or Maintenance Mode (RLV11/RLV12)	000
Write Check	001
Get Status	010
Seek	011
Read Header	100
Write Data	101
Read Data	110
Read Data without Header Check	111

4-5    **Bus Address Extension Bits (BA16, BA17)** – These are the two most significant bus address bits when operating in 18-bit addressing modes. They are read and written as data bits 4 and 5 of the cs register but considered as address bits 16 and 17 of the bus address register (see Paragraph 4.2.2).

**Table A-2 Control Status Register Bit Description (Cont)**

<b>Bit(s)</b>	<b>Description</b>																
6	<b>Interrupt Enable (IE)</b> – When this bit is set by software, the controller is allowed to interrupt the processor at the normal command or error termination.																
7	<b>Controller Ready (CRDY)</b> – When cleared by software, this bit indicates that the command code in bits 1-3 is to be executed (negative G0 bit). The hardware sets this bit to indicate the controller is ready to accept another command.																
8-9	<b>Drive Select (DS0, DS1)</b> – These bits determine which drive will communicate with the controller via the drive bus.																
10-13	<b>Error Code</b>																
	<table border="0"> <thead> <tr> <th><b>Error Name</b></th> <th><b>E3-E0</b></th> </tr> </thead> <tbody> <tr> <td>Operation Incomplete (OPI)</td> <td>0001</td> </tr> <tr> <td>Read Data CRC (DCRC or Write Check Error (WCE)</td> <td>0010</td> </tr> <tr> <td>Header CRC (HCRC)</td> <td>0011</td> </tr> <tr> <td>Data Late (DLT)</td> <td>0100</td> </tr> <tr> <td>Header Not Found (HNF)</td> <td>0101</td> </tr> <tr> <td>Non-Existant Memory (NXM)</td> <td>1000</td> </tr> <tr> <td>Memory Parity Error (MPE) RLV12 only</td> <td>1001</td> </tr> </tbody> </table>	<b>Error Name</b>	<b>E3-E0</b>	Operation Incomplete (OPI)	0001	Read Data CRC (DCRC or Write Check Error (WCE)	0010	Header CRC (HCRC)	0011	Data Late (DLT)	0100	Header Not Found (HNF)	0101	Non-Existant Memory (NXM)	1000	Memory Parity Error (MPE) RLV12 only	1001
<b>Error Name</b>	<b>E3-E0</b>																
Operation Incomplete (OPI)	0001																
Read Data CRC (DCRC or Write Check Error (WCE)	0010																
Header CRC (HCRC)	0011																
Data Late (DLT)	0100																
Header Not Found (HNF)	0101																
Non-Existant Memory (NXM)	1000																
Memory Parity Error (MPE) RLV12 only	1001																
14	<p><b>Drive Error (DE)</b> – This bit is tied directly to the DE interface line. When set, it indicates that the selected drive has flagged an error. (The source of the error can be determined by executing a get status command and then executing an MPR read.)</p> <p>DE can be cleared by executing a get status command with bit 3 of the DA register set.</p>																
15	<b>Composite Error (ERR)</b> – When set, this bit indicates that one or more of the error bits (bits 10-14) is set. If the IE bit (bit 6 of CS) is set and an error occurs (which sets bit 7), an interrupt will be initiated.																



**Table A-3 Bus Address Register Bit Description**

BUS ADDRESS REGISTER (BAR)															
15	14	13	12	11	10	09	08	07	06	05	04	03	02	01	00
BA15	BA14	BA13	BA12	BA11	BA10	BA9	BA8	BA7	BA6	BA5	BA4	BA3	BA2	BA1	0

READ/WRITE CZ-2035

Bit(s)	Name	Function
0-15	BA0 thru BA15	These bits point to the UNIBUS address that data is to be transferred to/from. Normally a memory address, BA16 and BA17 are in the CSR bits 4 and 5.

**Table A-4 Disk Address Register Bit Description for Seek Commands**

DAR DURING SEEK COMMAND															
15	14	13	12	11	10	09	08	07	06	05	04	03	02	01	00
DF8	DF7	DF6	DF5	DF4	DF3	DF2	DF1	DF0	0	0	HS	0	DIR	0	1

CZ-2010

Bit(s)	Description
0	<b>Marker Bit</b> – Must be a one.
1	<b>Seek</b> – Must be a zero, indicating to the drive that a seek is being requested. With this bit cleared, the drive uses the remaining contents of the register as seek parameters.
2	<b>Direction (DIR)</b> – This bit indicates the direction in which a seek is to take place. When the bit is set, the heads move toward the spindle (to a higher cylinder address). When the bit is cleared, the heads move away from the spindle (to a lower cylinder address). The actual distance moved depends on the cylinder address difference (bits 7-15).
3	Must be a zero.
4	<b>Head Select (HS)</b> – Indicates which head (disk surface) is to be selected. A one selects the lower head; a zero, the upper head.
5-6	Reserved.
7-15	<b>Cylinder Address Difference DF 08:00</b> – Indicates the number of cylinders the heads are to move on a seek.

**Table A-5 Disk Address Register Bit Description for Data Transfer Commands**

DAR DURING READING OR WRITING DATA COMMANDS															
15	14	13	12	11	10	09	08	07	06	05	04	03	02	01	00
CA8	CA7	CA6	CA5	CA4	CA3	CA2	CA1	CA0	HS	SA5	SA4	SA3	SA2	SA1	SA0

CZ-2011

Bit(s)	Description
0-5	<b>Sector Address SA 05:00</b> – Desired address of one of the 40 sectors on a track as supplied by the software (range is 0 through 47, octal).
6	<b>Head Select (HS)</b> – Desired head address of one of the two drive heads. A one indicates the lower head; a zero, the upper head.
7-15	<b>Cylinder Address CA 08:00</b> – Desired address of one of the cylinders on the disk (range is 0 through 777, octal). The RL01 has 256 cylinders and the RL02 has 512 cylinders.

**Table A-6 Disk Address Register Bit Description for Get Status Commands**

DAR DURING GET STATUS COMMAND															
15	14	13	12	11	10	09	08	07	06	05	04	03	02	01	00
X	X	X	X	X	X	X	X	0	0	0	0	RST	0	1	1

CZ-2037

Bit(s)	Description
0	<b>Marker Bit</b> – Must be a one.
1	<b>Get Status (GS)</b> – Must be a one, indicating to the drive that the status word is being requested. At the completion of the get status command, the drive status word is read into the controller multipurpose (MP) register. With this bit set, the drive ignores bits 8-15.
2	Must be a zero.
3	<b>Reset (RST)</b> – When this bit is set, the drive clears its error register (resets all drive faults) before sending the status word to the controller.
4-7	Must be a zero.
8-15	Not used during a get status.

**Table A-7 MP Register Bit Description for Get Status Commands**

MPR AFTER GET STATUS COMMAND

15	14	13	12	11	10	09	08	07	06	05	04	03	02	01	00
WDE	CHE	WL	SKTO	SPE	WGE	VC	DSE	DT	HS	CO	HO	BH	STC	STB	STA

CZ-2012

**Bit(s) Description**

0-2 **Major State Code (ST C:A)** – These bits define the state of the drive.

STC	STB	STA	
0	0	0	Load cartridge
0	0	1	Spin-up
0	1	0	Brush cycle
0	1	1	Load heads
1	0	0	Seek
1	0	1	Lock on
1	1	0	Unload heads
1	1	1	Spin-down

3 **Brush Home (BH)** – Set when the brushes are home.

4 **Heads Out (HO)** – Set when the heads are over the disk.

5 **Cover Open (CO)** – Set when the drive access cover is open or the dust cover is not in place.

6 **Head Select (HS)** – Indicates the currently selected head. A zero indicates the upper head; a one, the lower head.

7 **Drive Type (DT)** – A zero indicates an RL01; a one, an RL02.

8 **Drive-Select Error (DSE)** – Set when a multiple drive selection is detected.

9 **Volume Check (VC)** – Set during transition from a head load state to a head-on-track state. Cleared by execution of a get status command with bit 3 asserted.

10 **Write Gate Error (WGE)** – Sets when write gate is asserted and one or more of the following conditions exist.

- Drive is not “ready to read/write”
- Drive is write-protected
- Sector pulse is occurring
- Drive has another error

**Table A-7 MP Register Bit Description for Get Status Commands (Cont)**

Bit(s)	Description
11	<b>Spin Error (SPE)</b> – Set when spindle has not reached speed in the required time during spin-up or when spindle speed is too high.
12	<b>Seek Time Out (SKTO)</b> – Set when the heads do not come on-track in the required time during a seek command or when “ready to read/write” is lost while the drive is in position (lock-on) mode.
13	<b>Write Lock (WL)</b> – Set when the drive is write protected.
14	<b>Current Head Error (CHE)</b> – Set if write current is detected in the heads when write gate is not asserted (reading).
15	<b>Write Data Error (WDE)</b> – Set if write gate is asserted but no transitions are being detected on the write data line.

**Table A-8 MP Register Bit Description for Read Header Commands**

MPR AFTER READ HEADER COMMAND

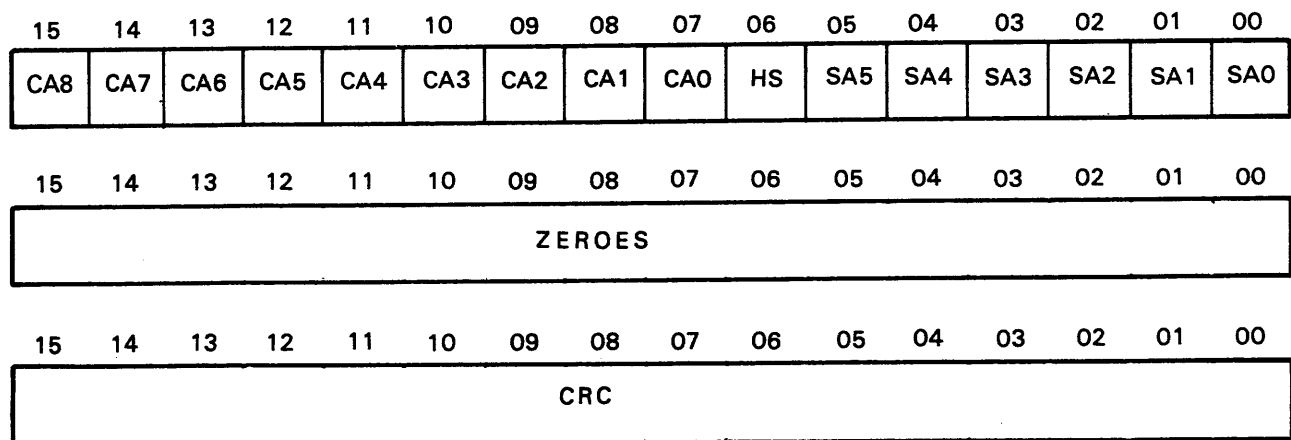

CZ-2013

Bit(s)	Description
0-5	<b>SA 0:5</b> – Sector Address
6	<b>HS</b> – Head Select
7-15	<b>CA 0:8</b> – Cylinder Address

**Table A-9 MP Register Bit Description for Data Transfer Commands**

MPR DURING READ/WRITE COMMANDS FOR WORD COUNT															
15	14	13	12	11	10	09	08	07	06	05	04	03	02	01	00
1	1	1	WC12	WC11	WC10	WC9	WC8	WC7	WC6	WC5	WC4	WC3	WC2	WC1	WC0

CZ-2036

Bit(s)	Description
0-12	Word Count WC 12:00 – Contains the two’s complement of total number of words to be transferred.
13-15	Must be ones.

**Multipurpose Register Programming Note – The RL01/RL02 Disk Drive will not do spiral read/writes. If data is to be transferred past the end of the last sector of a track, it is necessary to break up the operation into the following steps.**

1. Program the data transfer to terminate at the end of the last sector of the track.
2. Program a seek to the next track. This can be either a head switch to the other surface but same cylinder or a head switch and move to the next cylinder.
3. Program the data transfer to continue at the start of the first sector at the next track.

## A.1.2 CSR Error Code Definitions

### A.1.2.1 Operation Incomplete (OPI)

This error is flagged by the setting of bit 10 of the CSR. When bit 10 is set and 11 through 13 are clear, the indication is that the current command being executed did not complete within the OPI timer period. For an RL11, this timer period is 200 ms. For the RLV11 controller, the period is 490 ms. The RLV12 controller timer is set for 550 ms.

### A.1.2.2 Data CRC (DCRC) or Write Check (WCE)

This error is flagged by the setting of bit 11 of the CSR. When bit 11 is set and bit 10 is clear, the indication is either that a CRC error has occurred when reading data or that a write check error has occurred. If the function currently being executed is a write check command, then the probabilities are that the error is a WCE. If the function being executed is a read data command, then the error is a DCRC. A write data command cannot flag either of these errors.

### **A.1.2.3 Header CRC (HCRC)**

This error is flagged by the setting of bit 11 of the CSR. When bit 11 is set and bit 10 is also set, the indication is that a CRC error has occurred when reading a header. This error can set during write data or read data commands.

### **A.1.2.4 Data Late (DLT)**

This error is flagged by the setting of bit 12 of the CSR. When bit 12 is set and bit 10 is clear, the indication depends upon the command being executed.

- Write Data Command – The silo, or FIFO buffer, in the controller emptied before the word counter overflowed. This means that the command is not finished but the buffer contains no more words to write. When this happens the DMA cycles are too slow.
- Read Data Command – The silo, or FIFO buffer, in the controller is full and there are more words to read from the disk. When this happens, the DMA cycles are too slow causing data being read to be lost.

### **A.1.2.5 Header Not Found (HNF)**

This error is flagged by the setting of bit 12 of the CSR. When bit 12 is set and bit 10 is also set, the indication is that the desired header address could not be found before the OPI timer expired.

### **A.1.2.6 Non-Existant Memory (NXM)**

This error is flagged by the setting of bit 13 of the CSR. When bit 13 is set and bit 10 is clear, the indication is that the addressed memory did not respond to the DMA cycle request within 10 to 20 microseconds.

### **A.1.2.7 Memory Parity Error (MPE)**

This error is flagged by the setting of bit 13 of the CSR. When bit 13 is set and bit 10 is also set, the indication is that a data parity error was detected on a DMA cycle to the controller. This error applies to RLV12 controllers only.

## **A.1.3 Command Function Code Descriptions**

### **A.1.3.1 Write Check – Function Code 1**

The write check command is used to verify that data was written on the disk correctly. It is used after writing a block of data onto the disk by the write command function. The write check command reads this same block of data from the disk and compares it with the contents of its source data buffer area in main memory. Because this comparison is performed in the controller, this source data must be transferred out of memory and into the controller buffer.

Prior to issuing this command, the BA register must be loaded with the address of the first location of the data block in the main memory. The word counter register must be loaded with the data block length. The DA register is then loaded with the starting disk address location. At this point, the write check command can be loaded into the CS register.

Once the header is found, and the header CRC validates the match, 128 words of data are read from the disk. The disk data is then compared serially with the serial data coming out of the silo (SER DATA OUT). Either a compare error or a data CRC error will set bit 11 in the CS register.

#### **A.1.3.2 Get Status – Function Code 2**

The get status command causes the status word from a drive to be transferred to the controller where the software can access it through the MPR. The software should first verify that the controller is ready to perform an operation (the drive does not have to be ready). Then, the software should load the DAR with ones in bits 01 and 00, and zeros in the other locations. Next, the software should load the CSR with drive-select bits, a negative GO bit, IE bit (if desired) and a code of 2 in the function bits. The controller will then command the selected drive to transfer its status word to the MPR in the controller. If the “reset” bit (03) in the DAR is also set, the drive resets its status register before transferring it to the controller. This is the manner in which volume check is cleared or to check for hard errors.

#### **A.1.3.3 Seek – Function Code 3**

The seek operation causes the positioner to move (either forward or reverse) some number of cylinders. The software should first verify that the drive is ready to accept a command, then load the DAR with the difference word (difference between the present position and desired position). This word contains the number of cylinders to move (bits 15 through 07), the head-select bit (04) and the direction bit (bit 02, 1=forward, 0=reverse). Bits 06, 05 and 01 must be reset and bit 00 must be set. After the DAR is loaded, the software should load the CSR with the command word. This word should contain the drive-select bits, the negative GO bit, the IE bit (if desired), and a code of 3 in the function bits. The controller sends the seek command to the selected drive, causing the drive to start its seek operation. At this time, the controller becomes ready and interrupts if IE is set. The controller is now ready to accept another command to perform another operation on another drive while the seek is occurring.

If the difference word is large enough that the heads attempt to move past the innermost or outermost limits, the head will stop at the guard band and retreat to the first even-numbered data track.

#### **A.1.3.4 Read Header – Function Code 4**

When a read header function is decoded, the controller will read the first header encountered on the selected drive and place the three header words in the buffer. They pass through the buffer and stop with the first word in the MP register. The software can then access the first word to determine the current sector, head, and cylinder address. When the software extracts the first word from the MP register, the second word automatically moves into the MP register. If the software extracts the second word, the third word automatically moves into the MP. This is the CRC word. The software can now access it for checking purposes.

#### **A.1.3.5 Write Data – Function Code 5**

When this function is decoded with CRDY cleared, the controller reads successive header words and compares them to the DA register. When a match is found, the header CRC is checked and, if correct, that sector is written with the words from memory designated by the BA and/or BAE register(s). The BA and MP registers are incremented for each word that is transferred. For partial sector writes, the remaining sector area is filled with zeros. At the end of the sector, the sector portion of the DA register is incremented. The next sector is written if all the words have not been written. At the end of the transfer, CRDY is set and an interrupt made if IE is set.

#### **A.1.3.6 Read Data – Function Code 6**

When this function is decoded, the controller reads successive header words and compares them to the contents of the DA register. When a match is found, the header CRC is checked and, if correct, that sector is read and the words are placed in the memory location designated by the BA and/or BAE register(s). Both the BA and MP registers are incremented for each word that is transferred. This operation continues until the contents of the MP register are all zeros. Data CRC is checked and the DA register is incremented at the end of each sector. If the word count has not overflowed, the next sector is read. Otherwise, CRDY is set and an interrupt is made if IE is set.

### A.1.3.7 Read Data Without Header Check – Function Code 7

When this function is decoded, the data portion of the sector following the next sector pulse is read and the words requested are placed in the memory locations designated by the BA register. The BA and MP registers (word count in two's complement form) are incremented for each word transferred. The header is neither compared nor checked for CRC errors. Data CRC is checked at the end of a sector. If the word count has not overflowed, the next sector is read. Otherwise, CRDY is set and an interrupt is made if IE is set.

#### NOTE

The DA register is not incremented during multi-sector transfer.

## A.2 RL8A ADDRESSABLE REGISTERS

Table A-10 RL8A Instruction Set

OCTAL CODE	MNEMONIC	FUNCTION
6600	RLDC	Clear controller, all registers, AC and flags. (Do not use to terminate a disk function.)
6601	RLSD	Skip on function done, then clear if set to a 1
6602	RLMA	Load break MA register from AC 0:11
6603	RLCA	Load command register A from AC 0:11
6604	RLCB	Load command register B from AC 0:11, execute command
6605	RLSA	Load sector address register from AC 0:5
6607	RLWC	Load word count register from AC 0:11
6610	RRER	Read error register into AC 0, 1, 2, 10, 11
6611	RRWC	Read word count register into AC 0:11
6612	RRCA	Read command register A into AC 0:11
6613	RRCB	Read command register B into AC 0:11
6614	RRSA	Read sector address register into AC 0:5
6615	RRSI	Read silo word into AC 0:11
6617	RLSE	Skip on composite error, then clear if set to a one



### A.2.1 RL8A Register Description

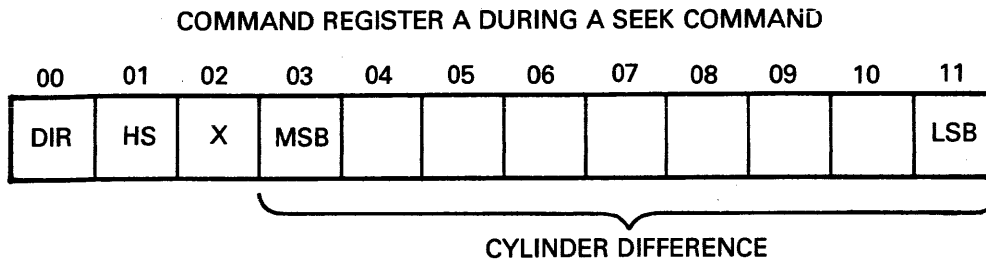

CZ-2016

**Table A-11 Command Register A During a Seek Command**

Bit(s)	Name	Function
AC0	Direction	This bit indicates the direction in which a seek is to take place. When the bit is set, the heads move toward the spindle (to a higher cylinder address). When the bit is cleared, the heads move away from the spindle (to a lower cylinder address). The actual distance moved depends on the cylinder address difference (bits 3-11).
AC1	Head Select (HS)	Indicates which head (disk surface) is to be selected. A 1 indicates the lower head; a 0, the upper head.
AC2	-	Spare
AC3:11	Cylinder Address Difference	Indicates the number of cylinders the heads are to move on a seek.

**Table A-12 Command Register A During Read or Write Data Command**

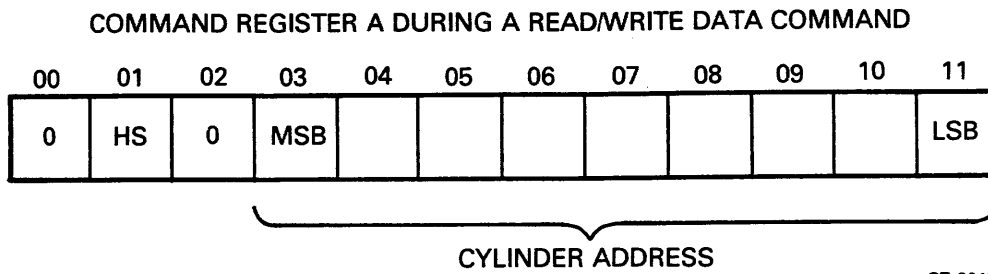

CZ-2017

Bit(s)	Name	Function
AC0	-	Must be 0
AC1	Head Select (HS)	Indicates which head (disk surface) is to be selected. A 1 indicates the lower head; a 0, the upper head. The correct track (head and sector) must be previously selected by a seek.
AC2	-	Must be 0
AC3:11	Cylinder Address	Cylinder address

**Table A-13 Command Register B**

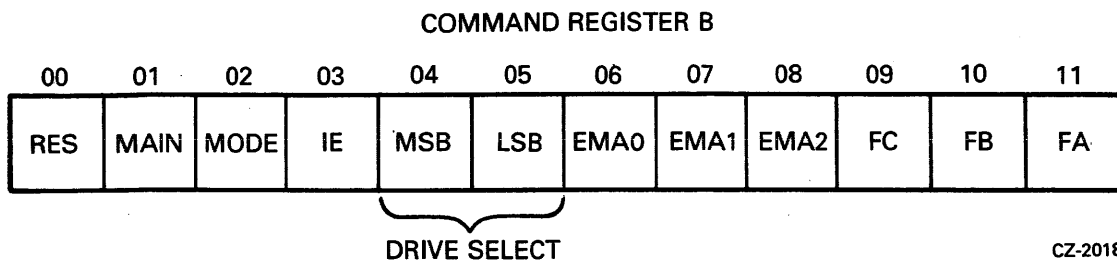

Bit(s)	Name	Function
AC0	-	Reserved
AC1	Maintenance	The contents of the disk address (DA) register are looped back to the silo for maintenance purposes. Bit 2 of command register B must also be set for this function to work correctly.
AC2	Mode	When set, this bit indicates that the data field will be 256 8-bit words per sector. When zero, the data field will be truncated to 170 12-bit words per sector. This bit must be set when a maintenance, a get status or a read header command is to be executed.
AC3	Interrupt Enable (IE)	When this bit is set, the controller is allowed to interrupt the processor at the conclusion of a normal command or error termination.
Bit(s)	Name	Function
AC4:5	Drive Select (DS0, DS1)	These bits determine which drive will communicate with the controller via the drive bus.
AC6:8	Extended Memory Addressed (EMA)	These three bits define the memory field location. This allows up to 32K memory locations to be addressed on processors having more than 4K of memory.
AC9:11	Function Code	These bits indicate the command to be executed by the controller/disk subsystem.

Bit 9	Bit 10	Bit 11	Command
0	0	0	Maintenance
0	0	1	Reset
0	1	0	Get Status
0	1	1	Seek
1	0	0	Read Header
1	0	1	Write Data
1	1	0	Read Data
1	1	1	Read Data Without Header Check

**Table A-14 Break Memory Address Register**

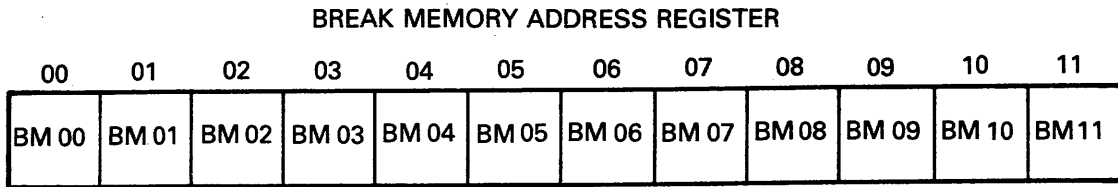

CZ-2019

Bit(s)	Name	Function
AC0:11	BM0:11	Memory Address

**Table A-15 Word Count Register**

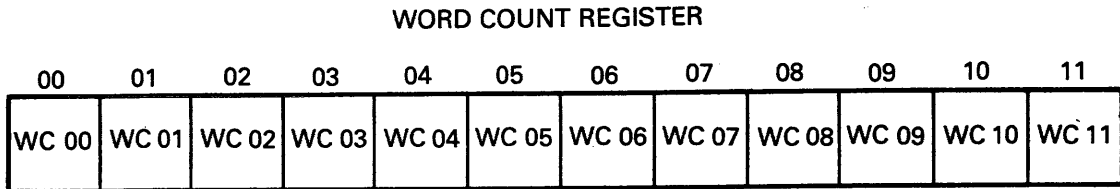

CZ-2020

Bit(s)	Name	Function
AC0:11	WC0:11	Word Count

**Table A-16 Sector Address Register**

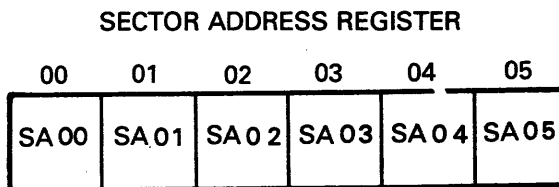

CZ-2021

Bit(s)	Name	Function
AC0:5	SA0:5	Sector Address

**Table A-17 Error Register**

ERROR REGISTER												
00	01	02	03	04	05	06	07	08	09	10	11	
DCRC	OPI	DLT	NOT DEFINED						DE	DRDY		
HCRC		HNF										

CZ-2022

Bit(s)	Name	Function
AC0	Data CRC (DCRC) or Header CRC (HCRC)	If OPI is cleared and this bit is set, the CRC error occurred in the data (DCRC). If OPI is set and this bit is also set, the CRC error occurred on the header (HCRC).
AC1	Operation Incomplete (OPI)	When set, this bit indicates that the current command was not completed within 200 milliseconds. It is also used in conjunction with bits 0 and 2 of this register.
AC2	Data Late (DLT) or Header Not Found (HNF)	<p>This bit is set during a write if the silo is empty and the word count is not yet 0 (meaning that no word was available for writing). OPI will not be set.</p> <p>This bit is set during a read if the silo is full and the word count is not yet 0 (meaning that the word being read could not enter the silo). OPI will not be set.</p> <p>When this bit and OPI are both set, then a 200 millisecond timeout occurred while the controller was searching for the correct sector to read or write (no header compare - HNF).</p>
AC10	Drive Error (DE)	<p>This bit is tied directly to the drive error interface line. When set, it indicates that the selected drive has flagged an error. The source of the error can be determined by a get status.</p> <p>The DE bit is cleared with a reset command to the drive.</p>
AC11	Drive Ready (DRDY)	When set, this bit indicates that the selected drive is ready to receive a command. The bit is cleared when a seek operation is initiated and set again when the seek operation is completed.

**Table A-18 Silo Buffer Word 1 of a Get Status Command**

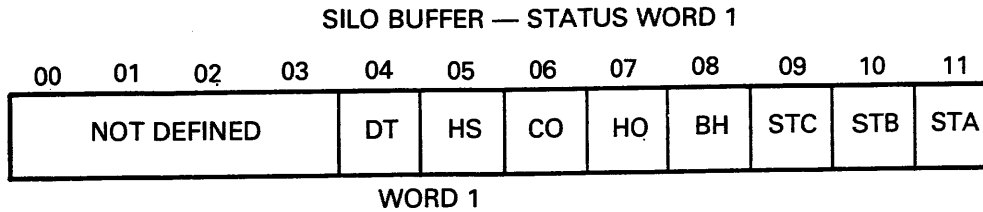

CZ-2023

Bit(s)	Name	Function
AC0:3	-	Undefined
AC4	Drive Type	A 0 indicates an RL01; a 1, an RL02.
AC5	Head Select (HS)	Indicates currently selected head. A 0 indicates the upper head; a 1, the lower head.
AC6	Cover Open (CO)	Set when the cartridge access cover is open or the dust cover is not in place.
AC7	Heads Out (HO)	A 1 indicates that the heads are over the disk; a 0 indicates that the heads are home.
AC8	Brush Home (BH)	Set when the brushes are home.
AC9:11	State Bits	These bits define the state of the disk drive.

**State Bit Definitions**

Bit A	Bit B	Bit C	Definition
0	0	0	Load Cartridge
0	0	1	Spin-up
0	1	0	Brush Cycle
0	1	1	Load Heads
1	0	0	Seek (track counting)
1	0	1	Lock-on (keeping on track)
1	1	0	Unload Heads
1	1	1	Spin-down

**Table A-19 Silo Buffer Word 2 of a Get Status Command**

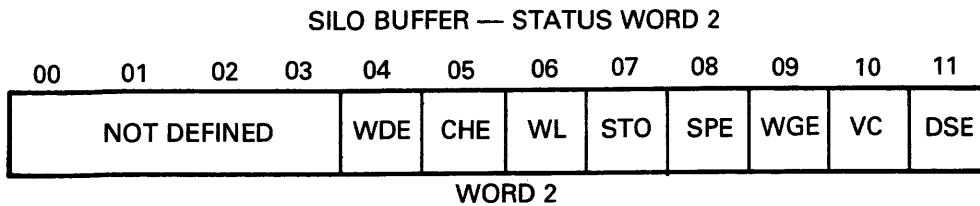

CZ-2024

Bit(s)	Name	Function
AC0:3	-	Undefined
AC4	Write Data Error (WDE)	This bit is set when write gate is on but no transitions were detected on the write data line.
AC5	Current Head Error (CHE)	This bit is set when write current is detected in the heads but write gate was not asserted.
AC6	Write Lock (WL)	Set when the drive is write protected.
AC7	Seek Time Out Error (SKTO)	Set when the heads do not come on track in the required time during a seek command or when “ready to read/write” is lost while the drive is in position (lock-on) mode.
AC8	Spin Error (SPE)	Set when the spindle does not come up to speed within 40 seconds or when the spindle speed is too high.
AC9	Write Gate Error (WGE)	Set if write gate is asserted and one or more of the following conditions is true. <ol style="list-style-type: none"> <li>1. Drive is not “ready to read/write”</li> <li>2. Drive is write protected</li> <li>3. Drive is in the midst of sector time</li> <li>4. Drive has another error asserted</li> </ol>
AC10	Volume Check (VC)	Set when a cartridge has been spun-up. This bit is reset by a get status command.
AC11	Drive Select Error (DSE)	Set when one or more drives have the same number (unit select plug) or have responded to the same number.

**Table A-20 Silo Data Buffer Contents Following a Read Header Command**

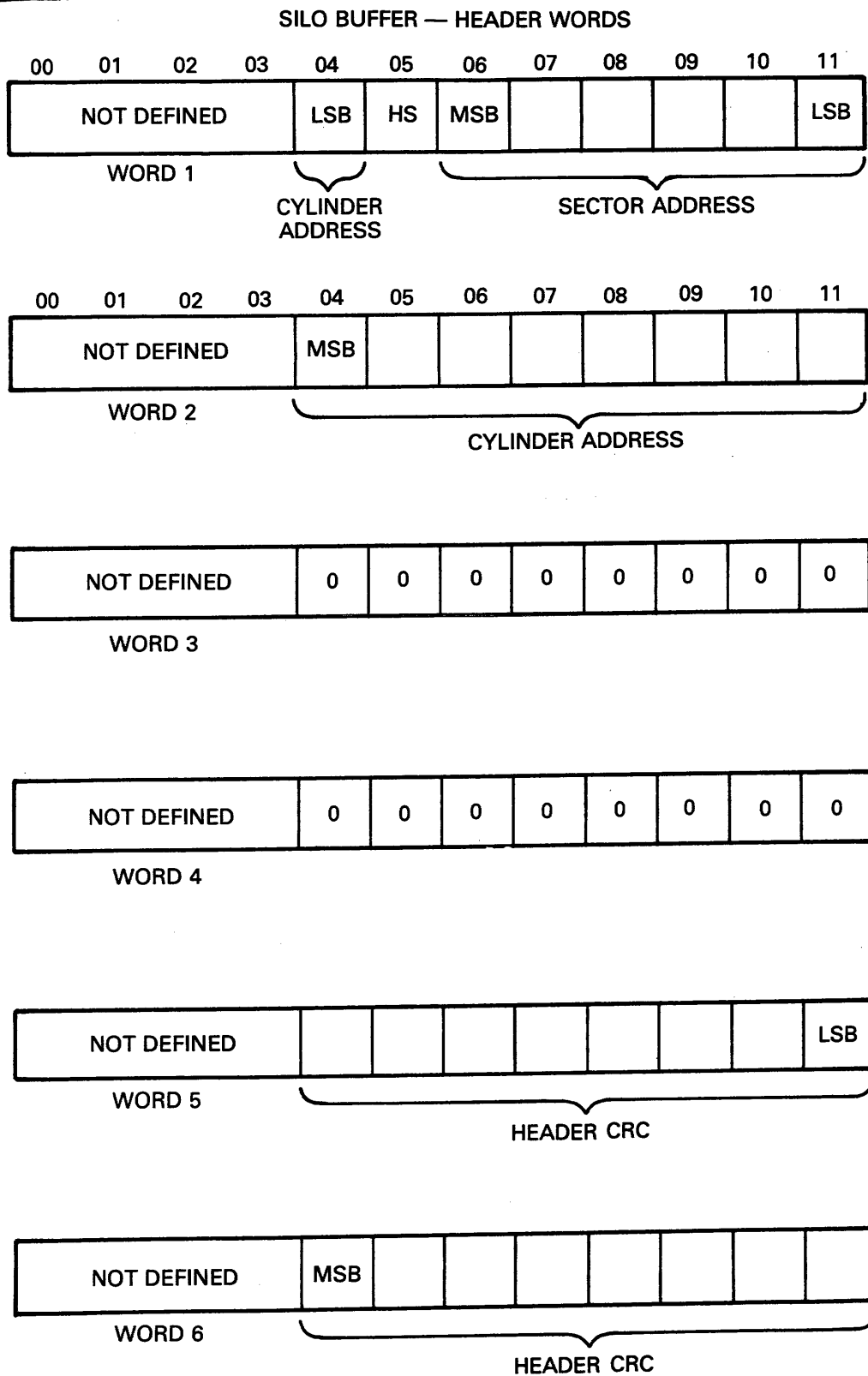



### WORD 1 – HEADER

Bit(s)	Name	Function
AC0:3	-	Undefined
AC5	Cyl Add	LSB of Cylinder Address
AC5	HS	Head Select – lower head = 1, upper head = 0
AC6:11	Sec Add	Sector Address

### WORD 2 – HEADER

Bit(s)	Name	Function
AC0:3	-	Undefined
AC4:11	Cyl Add	Cylinder Address – eight high order bits

### WORD 3 – HEADER

Bit(s)	Name	Function
AC0:3	-	Undefined
AC4:11	-	Zeros

### WORD 4 – HEADER

Bit(s)	Name	Function
AC0:3	-	Undefined
AC4:11	-	Zeros

### WORD 5 – HEADER

Bit(s)	Name	Function
AC0:3	-	Undefined
AC4:11	CRC	Eight LSB of CRC word

### WORD 6 – HEADER

Bit(s)	Name	Function
AC0:3	-	Undefined
AC4:11	CRC	Eight MSB of CRC word

## **A.2.2 RL8A Controller Commands**

The RL8A controller is capable of performing eight operations by responding to the function code in the low order three bits of command register B. In many cases it is necessary to load other registers prior to loading the function code into command register B. No registers should be loaded unless the controller is ready. This condition can be checked by using the appropriate IOT instruction that checks the function done status or by using the interrupt mode.

### **A.2.2.1 Maintenance Command**

This command tests the controller by causing it to perform the following tasks.

- The controller requests a data word from memory via the OMNIBUS using the break memory address (BRK MA) register as an address. When the controller receives this word, the BRK MA and the word count (WC) register are both incremented.
- The data word is bubbled through the silo, serialized and transferred (in 8-bit mode) through the CRC-generating logic where two more 8-bit bytes are appended. This 24-bit data stream goes through the write data precompensation logic and then is looped back and brought in as if it were read data from the drive. The data passes through the phase-locked loop and data separator logic and into the silo where it is converted back to parallel (eight bits per word), and bubbles through the silo to be available to the OMNIBUS.
- The controller requests three memory accesses and transfers the three words back to memory using the BRK MA register as a pointer. The BRK MA register and WC register are incremented for each transfer. The words are now available for the program to check for diagnostic purposes.
- The above processes repeat and the cycle continues until the WC register equals zero.

Prior to starting this command it is necessary to load the following registers.

- The BRK MA register should be loaded with the address of the first word of data to be transferred to the controller. The next three words of memory will receive three words of data from the controller.
- The WC register should be loaded with the desired count (in two's complement form). A complete cycle takes four counts.
- The command register B should be loaded with 10X0 or 14X0. This sets the mode bit to indicate 8-bit mode. The maintenance bit is a zero. The function code is 000. The remaining bits are irrelevant.

### **A.2.2.2 Reset Command**

This command is used to reset all of the error bits in the selected drive unit. It does not reset any conditions in the controller nor does it cause any head movement in the drive. Prior to executing this command, the sector address register and command register A must be cleared by using appropriate IOT instructions.

### **A.2.2.3 Get Status Command**

The get status command reads the 16-bit status word from the selected drive and transfers it into two 8-bit bytes in two consecutive words in the silo. The computer can then extract them with two IOT RRSI instructions. The format of the bits are shown in Paragraph 5.2.7.1. Prior to performing a get status command it is necessary to clear both the sector address register and command register A. When command register B is loaded with the function code, the appropriate drive-select bits should be set, the interrupt enable bit should be set if desired, and the mode bit must be set for 8-bit mode. The controller should be ready before performing any of these load register operations but the drive does not have to be ready.

### **A.2.2.4 Seek Command**

The seek command is used to move the heads or to select the other head on the selected drive. Prior to executing the seek command, the sector address register should be cleared and command register A should be loaded with a direction bit, a head-select bit, and cylinder difference word. Command register B is then loaded with the drive-select bits and the seek function code. The controller will send a command to the selected drive to cause it to start a seek operation. The controller will become ready and can then perform another command even though the drive is still seeking.

If the drive attempts to move the head past the innermost or outermost tracks, the head will retreat from the guard band and stop at the first even-numbered track it encounters.

### **A.2.2.5 Read Header Command**

The read header command will read the first header encountered on the selected drive and load the header into six consecutive word locations in the silo, one 8-bit byte per word. The computer can then extract this information with IOT RRSI instructions. The format of the information is shown in Paragraph 5.2.7.2. A check is performed on the header that is read.

### **A.2.2.6 Write Data Command**

The write data command requests data from memory, one word at a time, via the OMNIBUS using the DMA mode. It then transfers the data through the controller silo buffer to the selected drive. The data is written at the specified sector data area. This operation continues, incrementing both the break memory address register and the word count register once for each OMNIBUS transfer until the word count register reaches zero.

Prior to starting this command it is necessary to position the head over the desired track using a seek command. Then the registers should be loaded as follows:

- The break memory address register with the address of the first memory word to be transferred,
- The sector address register with the address of the first sector to be written,
- The word counter register with the two's complement of the number of words to be transferred,
- The command register A with the head-select bit and the cylinder address word,
- The command register B with a mode bit (8-bit or 12-bit mode), interrupt-enable bit (optional), drive-select bits, extended memory address bits, and the write data function code.

The write data command will then read headers and perform header checks until the desired header is located. After the header is checked, the data is transferred. The header check includes a header CRC check. There is no implicit seek performed, so if the selected head is not positioned over the desired track, the desired header will not be found and an OPI error will occur. If only a partial sector is written, the remainder of the sector is written with all zeros. A CRC word (16 bits) is generated and written for each sector automatically. Since the word count is limited to 4096, this means that the maximum amount of data that can be written with one write data command is 16 sectors in 8-bit mode. If 12 bit mode is used, a maximum of 170 words (one sector) can be transferred. The hardware will not perform a spiral (mid-transfer) seek. Therefore, if data must be written that would overflow to the next track, it is necessary to write the data to the end of the track, seek to the next track, and then continue to write the remainder of the data.

#### **A.2.2.7 Read Data Command**

The read data command will cause the controller to read data from the selected drive. It will read from the track that is currently under the selected head, starting at the specified sector. The data is transferred through the controller silo buffer. The controller requests DMA transfers to memory via the OMNIBUS. The break memory address and the word count registers are incremented once for each 12-bit word transferred over the OMNIBUS. When the word count register reaches zero, the read data command is terminated. Prior to starting the read data command, the head should be positioned over the desired track with a seek command. Load the registers as follows:

- The break memory address register with the address of the first location in memory to which the data is to be transferred,
- The sector address register with the address of the first sector from which the data is to be read,
- The word counter register with the two's complement of the number of words of data to be read,
- The command register A with a head-select bit and a cylinder address word,
- The command register B with a mode bit and interrupt-enable bit (optional) drive-select bits, extended memory address bits, and the function code for read data.

The read data command then reads headers, comparing them to the desired disk address. The data transfer begins when the desired header is found. The header checks include header CRC checks. There is no implicit seek, so if the selected head is not over the desired track, the desired header will not be found and an OPI error will occur.

The RL8A cannot perform a spiral (mid-transfer) seek. If a block of data to be read passes the end of a track and continues on the other surface or on the next cylinder, it is necessary to program a read data just to the end of the track. The drive must then seek to the next track and then continue reading data.

A CRC check is performed on each sector during a read data operation.

#### **A.2.2.8 Read Data without Header Check Command**

This command is the same as a read data command except that no header check is performed. The next header read is considered a match so that sector is the first sector read. Since no header check takes place, no header CRC is performed.

### **A.2.2.9 Maintenance Bit**

The maintenance bit in command register B enables a path for the serial information leaving the DA register. When this bit is set, the data that is going out to the drive is looped back and shifted into the silo. The data bubbles through the silo and becomes accessible (as two 8-bit bytes) to IOT RRSI instructions. The program can then monitor the operation of the DA register which is not a directly addressable register. This feature must be used only with reset, get status, and seek commands. Because the DA register is a 16-bit register, the 8-bit mode bit should be set. This insures that the contents of the DA register fit into two 8-bit bytes. The contents of the DA register and the two silo words are illustrated in Figure 5-12. During the loading of the DA register (which occurs on every command), there is more than one input to some of the bit positions. These inputs are ORed together. Normally, Status Register A is cleared before any reset, get status, or seek command and control register A is cleared before any reset or get status command. It is possible to test all the bits in the DA register by using selected patterns in control register A and status register A.

## APPENDIX B INSTALLATION

### B.1 SITE PREPARATION AND PLANNING

This appendix describes power, space, environmental, cabling and safety requirements that must be considered before installing the RL01/RL02 Disk Subsystem.

#### B.1.1 Environmental Considerations

The RL01/RL02 Disk Subsystem is designed to operate in a business or light industry environment. Although cleanliness is an important consideration in the installation of any computer system, it is particularly crucial for proper operation of a disk drive. The RL01K/RL02K Disk Cartridge is not sealed while being loaded and is therefore vulnerable to dust or smoke particles suspended in the air, as well as fingerprints, hair, lint, etc. These minute obstructions can cause head crashes, resulting in severe damage to the read/write heads and disk surfaces.

**B.1.1.1 Cleanliness** – The RL01/RL02 Disk Drives can operate in an ambient with less than one million particles per cubic foot of air which are 0.5 micron or larger in diameter. The drive contains a filter system which, under these conditions, maintains the particle count within the cartridge below 100 particles per cubic foot.

**B.1.1.2 Space Requirements** – Provision should be made for service clearances of 1 m (36 in) at the front and rear of the rack or cabinet in which the drive is mounted and 1 m (36 in) at either side.

Storage space for the RL01K/RL02K cartridges should also be made available. Each cartridge has a diameter of approximately 38 cm (15 in) and a height of approximately 6 cm (2.5 in).

#### CAUTION

**RL01K/RL02K disk cartridges must never be stacked on top of each other. A designated shelf area or specially designed disk cartridge storage unit is recommended (see the DIGITAL Supplies and Accessories Catalog).**

**B.1.1.3 Floor Loading** – The weight of the RL01/RL02 Disk Drive alone is 34 kg (75 lb), which will not place undue stress on most floors. However, the added weight of the rack or cabinet as well as the number of drives to be installed should be considered in relation to the weight of existing computer systems. Possible future expansion should also be a consideration.

**B.1.1.4 Heat Dissipation** – The heat dissipation of each RL01/RL02 Disk Drive is 546 Btu/hour maximum. The approximate cooling requirements for the entire system can be calculated by multiplying this figure by the number of drives, adding the result to the total heat dissipation of the other system components, and then adjusting the total figure to compensate for personnel, cooling system efficiency, etc. It is advisable to allow a safety margin of at least 25 percent above the maximum estimated requirements.

**B.1.1.5 Acoustics** – Most computer sites require at least some degree of acoustical treatment. However, the RL01/RL02 Disk Subsystem should not contribute unduly to the overall system noise level. Ensure that acoustical materials used do not produce or harbor dust.

**B.1.1.6 Temperature** – The RL01/RL02 Disk Subsystem will operate over a temperature range of 10° C (50° F) to 40° C (104° F). The maximum temperature gradient is 16.6° C (30° F) per hour. The nonoperating temperature range is from –40° C (–40° F) to 66° C (151° F).

**B.1.1.7 Relative Humidity** – Humidity control is important for proper operation of any computer system since static electricity may cause memory errors or even permanent damage to logic components. The RL01/RL02 Disk Subsystem is designed to operate within a relative humidity range of 10 to 90 percent, with a maximum wet bulb temperature of 28° C (82° F) and a minimum dew point of 2° C (36° F). The nonoperating relative humidity range is from 10 to 95 percent, with a maximum wet bulb temperature of 46° C (115° F).

**B.1.1.8 Altitude** – Computer systems operating at high altitudes may have heat dissipation problems. Altitude also affects the flying height of read/write heads in disk drives. The maximum altitude specified for operating the RL01/RL02 Disk Subsystem is 2440 m (8000 ft). Also, the maximum allowable operating temperature is reduced by a factor of 1.8° C per 1000m (1° F per 1000 ft) above sea level. Thus, the maximum allowable operating temperature at 2440 m (8000 ft) would be reduced to 36° C (96° F).

**B.1.1.9 Power and Safety Precautions** – The RL01/RL02 Disk Subsystem presents no unusual fire or safety hazards to an existing computer system. AC power wiring should be checked carefully, however, to ensure that its capacity is adequate for the added load as well as for any possible expansion. The RL01/RL02 Disk Drive is UL listed and CSA certified.

**B.1.1.10 Radiated Emissions** – Any source of electromagnetic interference (EMI) that is near the computer system may affect the operation of the processor and its related peripheral equipment. Common EMI sources that are known causes of failures include:

- Thunderstorms
- Broadcast stations
- Radar
- Mobile communications
- High-voltage power lines
- Power tools
- Arc welders
- Vehicle ignition systems
- Static electricity

The effect of radiated EMI emissions on a computer system is unpredictable. Thus, grounding plays an important role in protecting the circuits used in disk drive subsystems.

To help reduce the effects of known high-intensity EMI emissions perform the following actions:

- Ground window screens and other large metal surfaces.
- Ensure that the overall computer system is grounded properly (refer to Paragraph B.14, Grounding Requirements).
- Provide proper storage (metal cabinets with doors) for disk cartridges.

**B.1.1.11 Attitude/Mechanical Shock** – Performance of the RL01/RL02 Disk Subsystem will not be affected by an attitude where maximum pitch and roll do not exceed 15 degrees.

The subsystem is designed to operate while a half-sine shock pulse of 10 gravity peak and 10 ↑ 3 ms duration is applied once in either direction of three orthogonal axes (three pulses total).

**B.1.2 Options**

The RL01/RL02 Disk Drive can be shipped with various controllers (for Unibus, Ommibus and LSI-11 Bus computer systems), and can be configured for 115 Vac 230 Vac operation.

Table B-1 shows saleable RL01/RL02 subsystem options. Table B-2 shows RL01/RL02 option components.

**Table B-1 Saleable RL01/RL02 Subsystem Options**

Option Number	Description
RL01A	RL01 unit, BC20J I/O cable, chassis slide and mounting hardware
RL02A	RL02 unit, BC20J I/O cable, chassis slide and mounting hardware
RL01-AK	RL01-A (drive), RL01K-DC (cartridge)
RL02-AK	RL02-A (drive), RL02K-DC (cartridge)
RL01K-DC	RL01 data cartridge
RL02-DC	RL02 data cartridge
RL11-AK	RL01-AK, RL11 controller, BC06R, terminator
RL211-AK	RL02-AK, RL11 controller, BC06R, terminator
RLV11-AK	RL01-AK, RLV11 controller, BC06R, terminator
RLV12-AK	RL02-AK, RLV11 controller, BC06R, terminator
RL8A-AK	RL01-AK, RL8A controller, BC80J, terminator
RL28A-AK	RL02-AK, RL8A controller, BC80J, terminator
RLV21-AK	RL01-AK, RLV12 controller, BC80M, terminator
RLV22-AK	RL02-AK, RLV12 controller, BC80M, terminator



**NOTE**

**BC20J cables come in lengths of 20, 40 or 60 feet. If 10 foot cables are desired, then the cable designation becomes 70-12122-10. Total length of cables from this controller to the last drive must not exceed 30 M (100 ft.).**

**Table B-2 Saleable Cabinet Options:  
(Includes Skins, Doors,  
Covers, Trim, and Power  
Controllers)**

<b>Type</b>	<b>Volts</b>	<b>Dwg.</b>	<b>Remarks</b>	
H950	110 220	H960-BC H960-BD	Includes five 26.67 cm (10.5 in) high panels	
H967	110 220	H967-BA H967-BB	26.67 cm (10.5 in) cover panels (H950-QA) must be ordered if required	
H9500	110	H9603-ED	SWLB with H9514-B top covers	
	220	H9603-EE	DWLB with H9514-A top covers	
	110	H9601-ED		
	220 110	H9601-EE H9602-EA	SWHB complete hiboy cabinet	
H9500	220	220 110	H9602-EB H9600-EA	DWHB complete hiboy cabinet
		H9600-EB H9602-B-O	SWHB option arrangement dwg. Order as required	
		H9600-A-O	DWHB option arrangement dwg. Order as required	
H9500	220	H9603-B-O	SWLB option arrangement dwg. Order as required	
		H9601-A-O	DWHB option arrangement dwg. Order as required	

### B.1.3 AC Power Requirements

The RL01 or RL02 drive can operate within one of two voltage ranges that are manually selected by means of two terminal blocks located at the rear of the device (Figure B-1). These voltage ranges are:

	110 Vac	220 Vac
NOM	105-128	210-256
LO	90-111	180-220

The drive will operate when the line frequency is between 47.5 and 63 Hz.

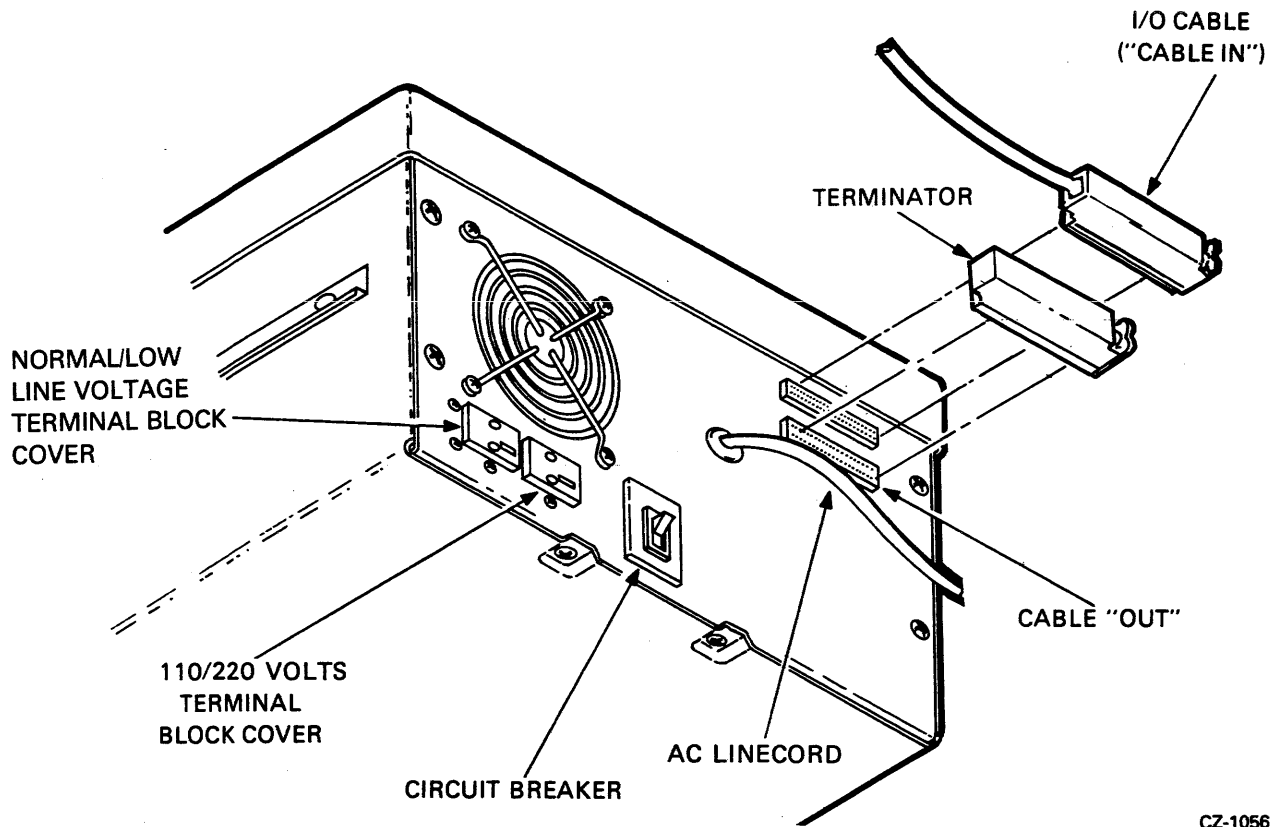

CZ-1056

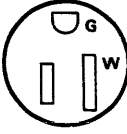



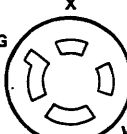

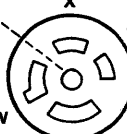

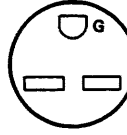

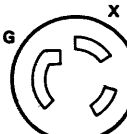



Figure B-1 RL01/RL02 Disk Drive – Rear View

**B.1.3.1 Standard Applications** – The drive can be shipped from the factory as a free-standing unit or mounted in various racks and cabinets (refer to Paragraph B.1.2, Options).

If the drive is shipped as a free-standing unit, the 2.74 m (9 ft) ac power cord is terminated with a NEMA type 5-15P plug (DIGITAL Part No. 90-08938). This plug requires a NEMA type 5-15R receptacle (Figure B-2).

**B.1.3.2 Optional Applications** – Operation in the high voltage range (180-256 Vac) will require re-configuring the terminal block at the rear of the drive and changing the line cord plug (Figure B-1).

In 50 Hz applications, the line cord plug must be changed (Figure B-2).

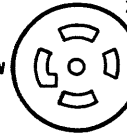
SOURCE	PLUG	RECEPTACLE	USED ON	
120V 15A 1-PHASE	 HUBBEL #5266-C NEMA # 5-15P DEC # 90-08938	 #5262 5-15R 12-05351	ALL 120V TABLE-TOP COMPUTERS. STANDARD 120V LOW-CURRENT DISTRIBUTION. 120V TU10 UNITS. MOST 120V TERMINAL DEVICES.	POWER CONTROLLER 861-F
120/208V 30A 3-PHASE Y	 HUBBEL #2611 NEMA # L5-30P DEC # 12-11193	 #2610 L5-30R 12-11194	ALL 120V STANDARD CABINET MOUNTED EOPT	POWER CONTROLLER 861-C
120/208-240V 20A 2-PHASE or 120/208V 20A 3-PHASE Y	 HUBBEL #2411 NEMA # L14-20P DEC # 12-11045	 #2410 L14-20R 12-11046	120V PDP-11/46 PROCESSOR CABINET ONLY.	POWER CONTROLLER 861-A
120/208V 20A 3-PHASE Y	 HUBBEL #2511 NEMA # L21-20P DEC # 12-11209	 #2510 L21-20R 12-11210	60 Hz RM 10 DRUM 60 Hz RP02/RP03/ RP04, RP05, RP06	
240V 15A 1-PHASE	 NEMA # 6-15P DEC # 90-08853	 6-15R 12-11204	ALL 240V TABLE-TOP COMPUTERS. STANDARD LOW-CURRENT 240V DISTRIBUTION. MOST 240V TERMINAL DEVICES. 240V TU10.	
240V 20A 1-PHASE	 HUBBEL #2321 NEMA # L6-20P DEC # 12-11192	 #2320 L6-20R 12-11191	ALL 240V STANDARD CABINET MOUNTED EQUIPMENT.	POWER CONTROLLER 861-B
240/416V 20A 3-PHASE Y	 NEMA # -- NOT NEMA DEC # 12-09010	 NOT NEMA 12-11259	50 Hz RM10 DRUM 50 Hz RP02/RP03/ RP04	
120V 30A 1-PHASE	 HUBBEL #2811 NEMA L21-30P DEC 12-12314	 #2810 L21-30R 12-12315	PDP11/70 PROCESSOR PDP 11/70 MEM. VAX-11/780 PROCESSOR	POWER CONTROLLER 861-D

CP-1968

Figure B-2 Approved Electrical Plugs and Receptacles

### B.1.4 Grounding Requirements

Each cabinet of a DIGITAL computer system is equipped with ground lug terminals that should be connected to a low-impedance earth ground by No. 4 AWG (5 mm/0.20 in) copper wire or stranded No. 4 AWG welding cable. A Burndy QA4C-B solderless lug (or equivalent) is recommended for terminating the cable. DIGITAL supplies a standard grounding conductor with each I/O and memory cabinet.

A steel building beam is an adequate ground in many instances. However, some disk-oriented systems may require additional connections to earth ground, in addition to the ground leads carried through various signal buses and ground connectors contained within the power cables. The green grounding wire in the power cable must also be returned to ground, usually through the conduit of the electrical distribution system. Note that the green wire is not a current-carrying conductor, nor a neutral conductor.

Whenever possible, the system power panel must be either mounted in contact with bare building steel by bonded joints (Figure B-3) or connected to the steel by a short length of cable.

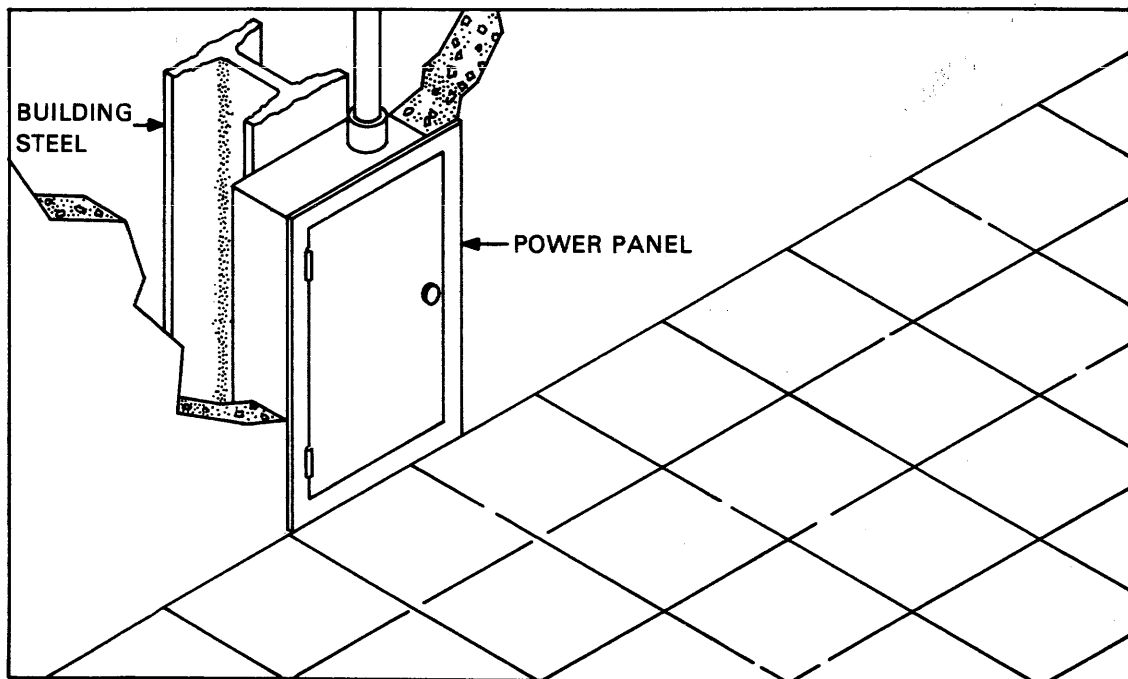

08-0717

Figure B-3 Power Panel Grounded to Building Frame

Where neither scheme is possible, a metal area (comprising the power panel, the conduit, and a metal plate) of at least 1 m<sup>2</sup> (10 ft<sup>2</sup>) that is in contact with masonry must be connected to the green ground wire (Figure B-4). The connecting wire must not exceed 1.5 m (5 ft) in length and should be at least a No. 12 AWG (2 mm).

When two cabinets are bolted together, DIGITAL bonds them electrically with a No. 4 AWG conductor (5 mm/0.20 in) or by several copper mesh straps connected between the cabinet frames.

After the grounding system is installed, it is advisable to take a voltage reading between the cabinet frame and the nearest grounded object. NBFU No. 70 (published by the National Bureau of Underwriters) provides further details regarding preferred grounding procedures.

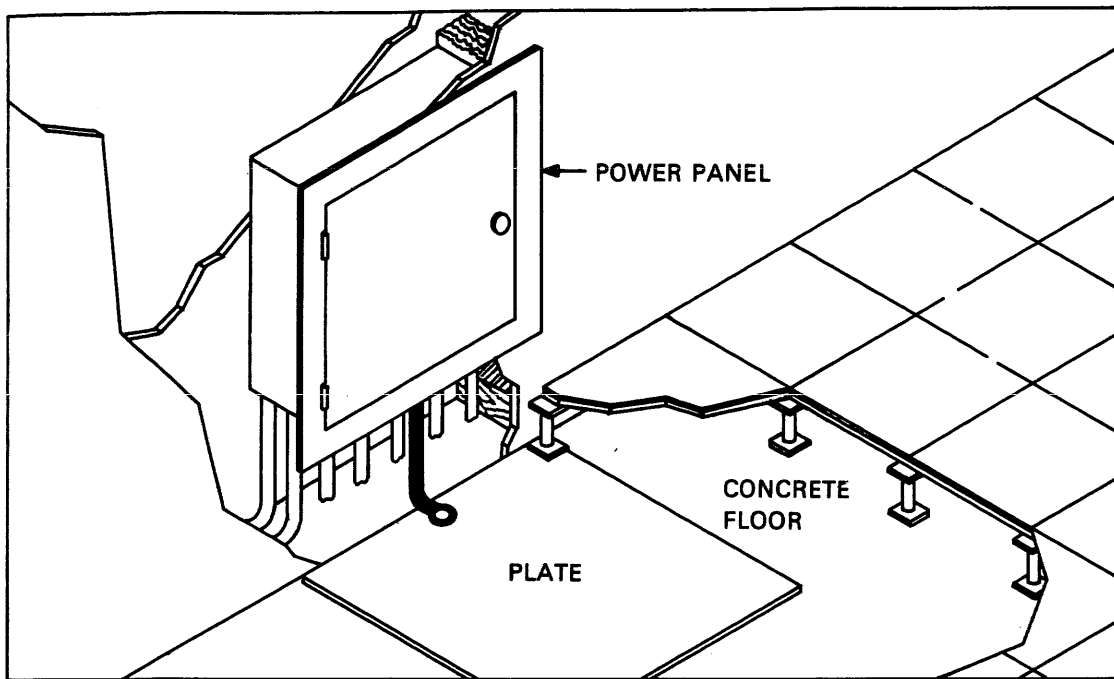

08 - 0718

Figure B-4 Power Panel Grounded to Metal Plate

### B.1.5 Installation Constraints

The route from the receiving area to the installation site that the equipment will travel should be studied in advance to ensure problem-free delivery. Among the considerations are:

- Height and location of loading doors
- Size, capacity, and availability of elevators
- Number and size of aisles and doors en route
- Bends or obstructions in hallways.

### B.2 AC CABLING

DIGITAL power wiring conforms to Underwriters Laboratories, Inc., Handbook UL No. 478, National Electrical Code standards, and the type II requirements of the National Fire Protection Association (NFPA 70). This means that in the United States the wire used as equipment ground is green, or green with a yellow stripe; it carries no load current (except in emergency), but does carry leakage current. No equipment is permitted to leave DIGITAL that does not have a grounding connection to its frame.

The grounded conductor is light grey or white. It must not be used to ground equipment. Its purpose is to conduct current.

Lines 1, 2, and 3 in a typical 60 Hz power system (Figure B-5) are represented by black, red, and blue wires, respectively, and phase rotation is in that order.

#### NOTE

Where no grounded wire can be guaranteed, it must not be assumed. There are some 115 V/60 Hz systems within the United States where neither side of the line is grounded (115 V 3-phase delta).

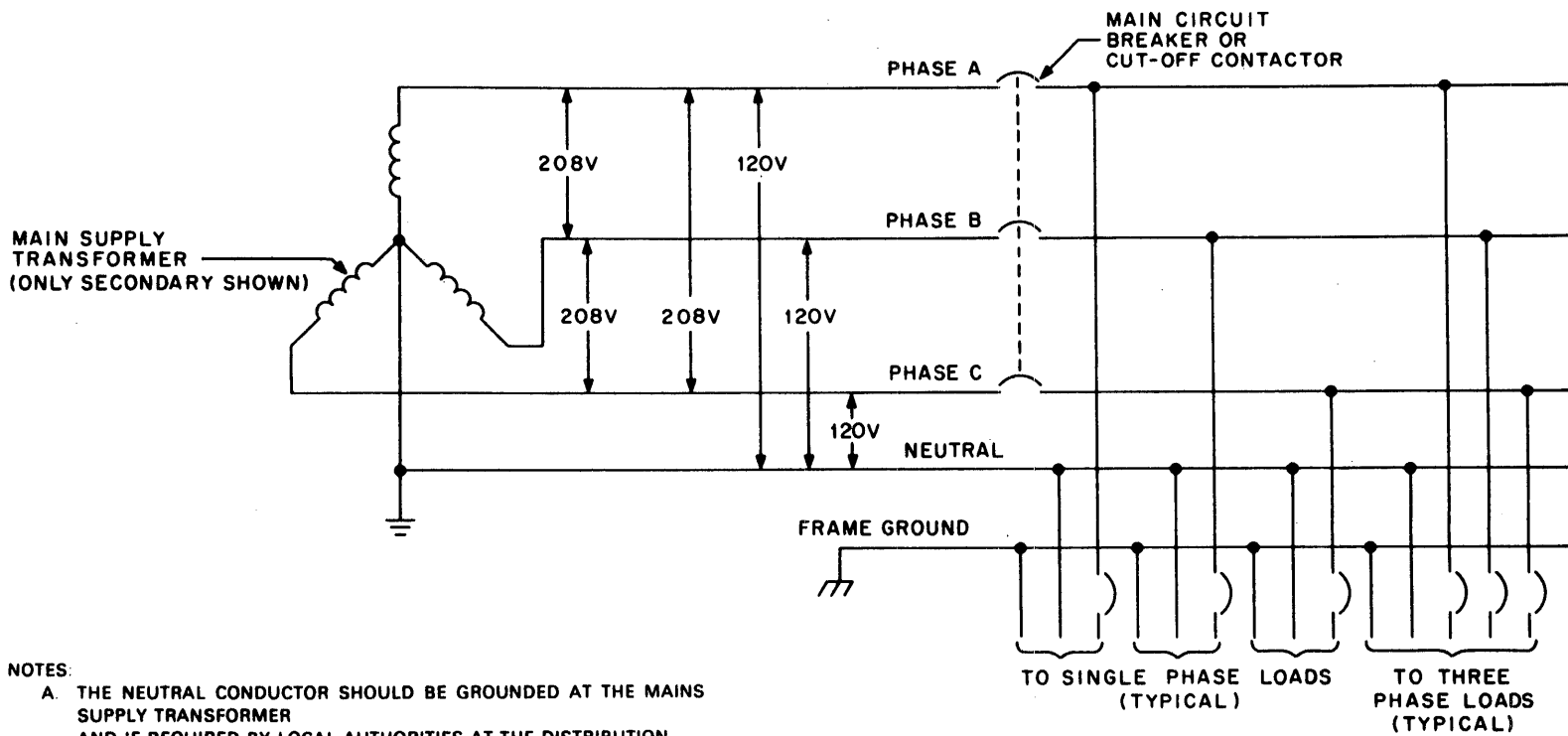

**NOTES:**

- A. THE NEUTRAL CONDUCTOR SHOULD BE GROUNDED AT THE MAINS SUPPLY TRANSFORMER AND IF REQUIRED BY LOCAL AUTHORITIES AT THE DISTRIBUTION PANEL AND ELSEWHERE.
- B. THE FRAME GROUND CONDUCTOR MAY CONSIST OF ELECTRICAL METALLIC CONDUIT OR RACEWAY IF APPROVED BY LOCAL AUTHORITIES.

MA-1185

Figure B-5 Typical 60 Hz Power System

Figure B-6 shows a typical 50 Hz power system.

Two types of power systems can be used to provide power to the NEMA type L14-20R receptacle. The type shown in Figure B-7 is referred to as split-phase (or 2-phase 180° displaced) 120/240 Vac. It comprises a center-tapped transformer with 120 Vac between the center tap and either of the two legs. 240 Vac exists between the two outside legs.

The second type (Figure B-8) is referred to as 3-phase Y (120° displaced) 120/280 Vac. The 120 Vac exists between neutral and any of the three other legs (X, Y, or Z), and 208 Vac exists between any two of the outer legs (i.e., between X and Y, X and Z, or Y and Z). Although Figure B-8 shows the X and Y connections as the two phases used for the receptacle, any two of the three phases shown can be used.

The ground terminal on the L14-ZOR receptacle will normally have a green screw, the neutral terminal will be white or silver, and the "hot" terminal will be brass covered.

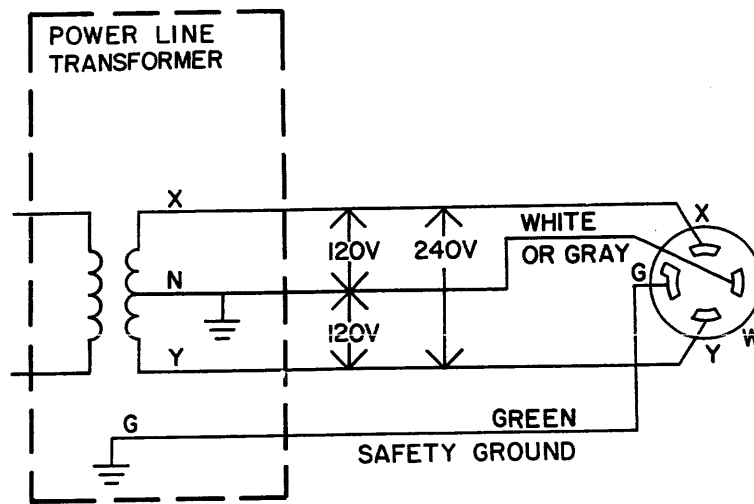

(A) 120/240V SPLIT-PHASE (TWO PHASE)

Figure B-7 Split Phase (2-Phase) Power System

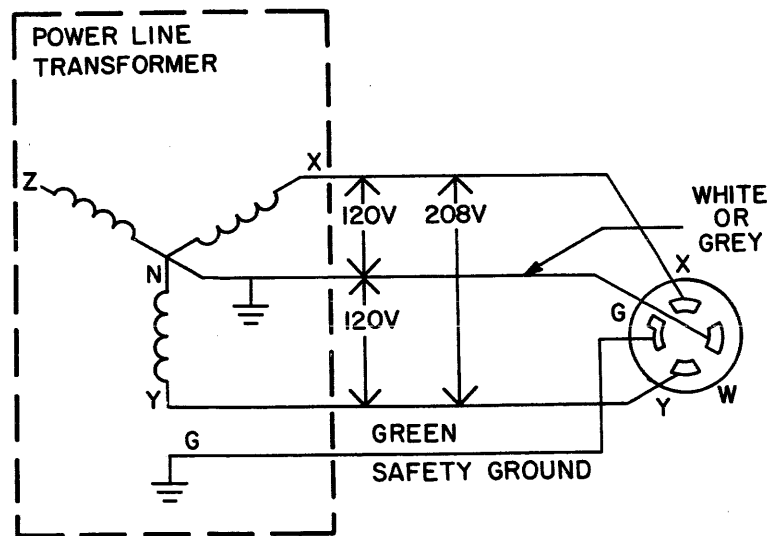

(B) 120/208V THREE PHASE

11-2294

Figure B-8 Three Phase Y Power System

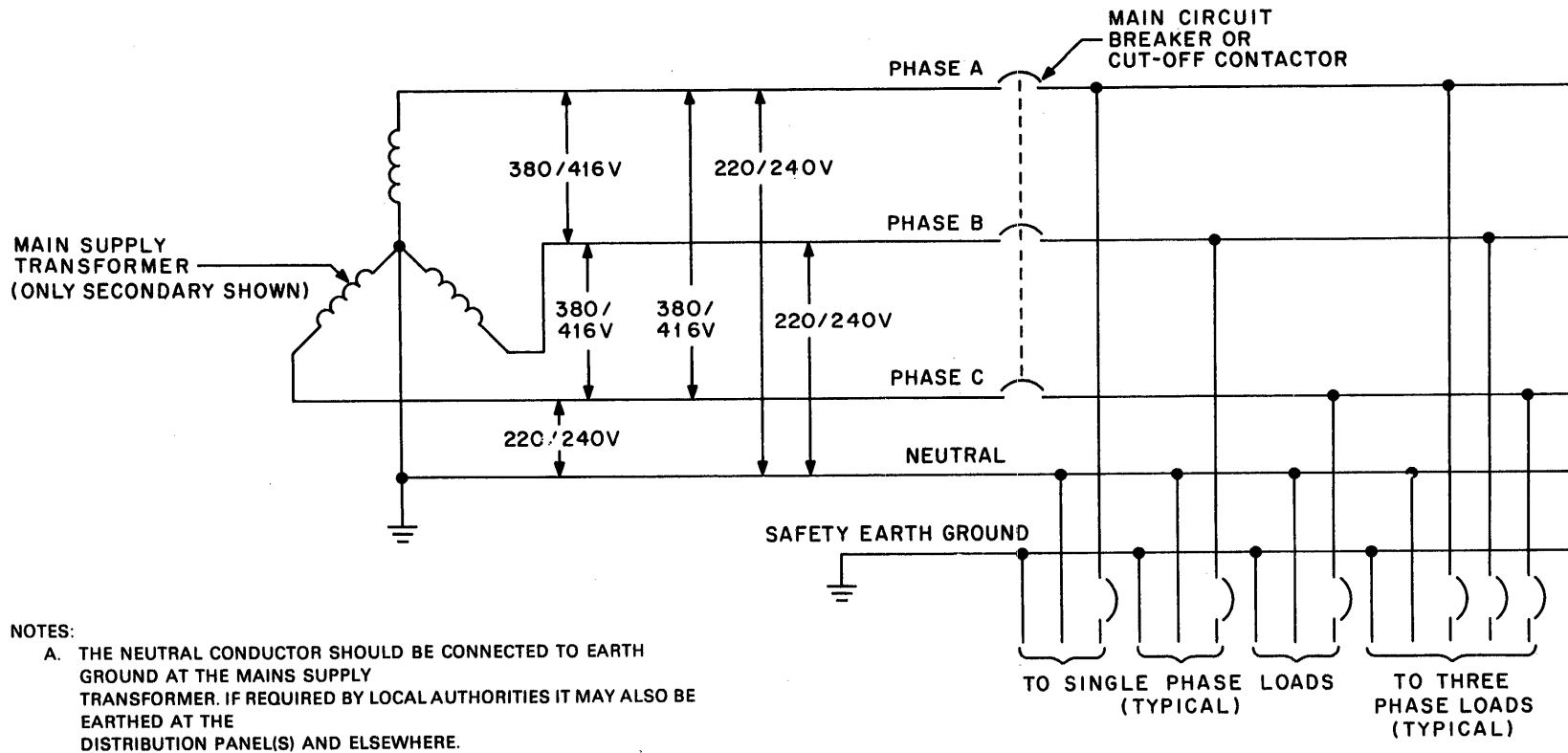

## NOTES:

- A. THE NEUTRAL CONDUCTOR SHOULD BE CONNECTED TO EARTH GROUND AT THE MAINS SUPPLY TRANSFORMER. IF REQUIRED BY LOCAL AUTHORITIES IT MAY ALSO BE EARTHED AT THE DISTRIBUTION PANEL(S) AND ELSEWHERE.
- B. THE SAFETY EARTH GROUND CONDUCTOR MAY CONSIST OF ELECTRICAL METALLIC CONDUIT OR RACEWAY IF APPROVED BY LOCAL AUTHORITIES.

Figure B-6 Typical 50 Hz Power System



### B.3 INSTALLATION - GENERAL

The controller should be installed first, followed by the drive(s). Next, the diagnostics should be run to demonstrate that the subsystem is functioning properly or to diagnose any problems. Paragraph B.4 explains the installation of the RL11 Controller, Paragraph B.5 deals with the RLV11, Paragraph B.6 describes RLV12 installation, and Paragraph B.7 describes RL8-A installation.

Paragraph B.8 contains instructions to install the unit and Paragraph B.9 explains acceptance testing and contains separate paragraphs for each of the three controllers. Paragraph B.10 describes the use of the M9312 bootstrap module that may be used on RL11-based systems.

### B.4 RL11 CONTROLLER INSTALLATION

The RL11 Controller (M7762) is a single hex-height module that is installed in any hex-height SPC slot. Connector J1 connects the controller to the drive bus (Figure B-9).

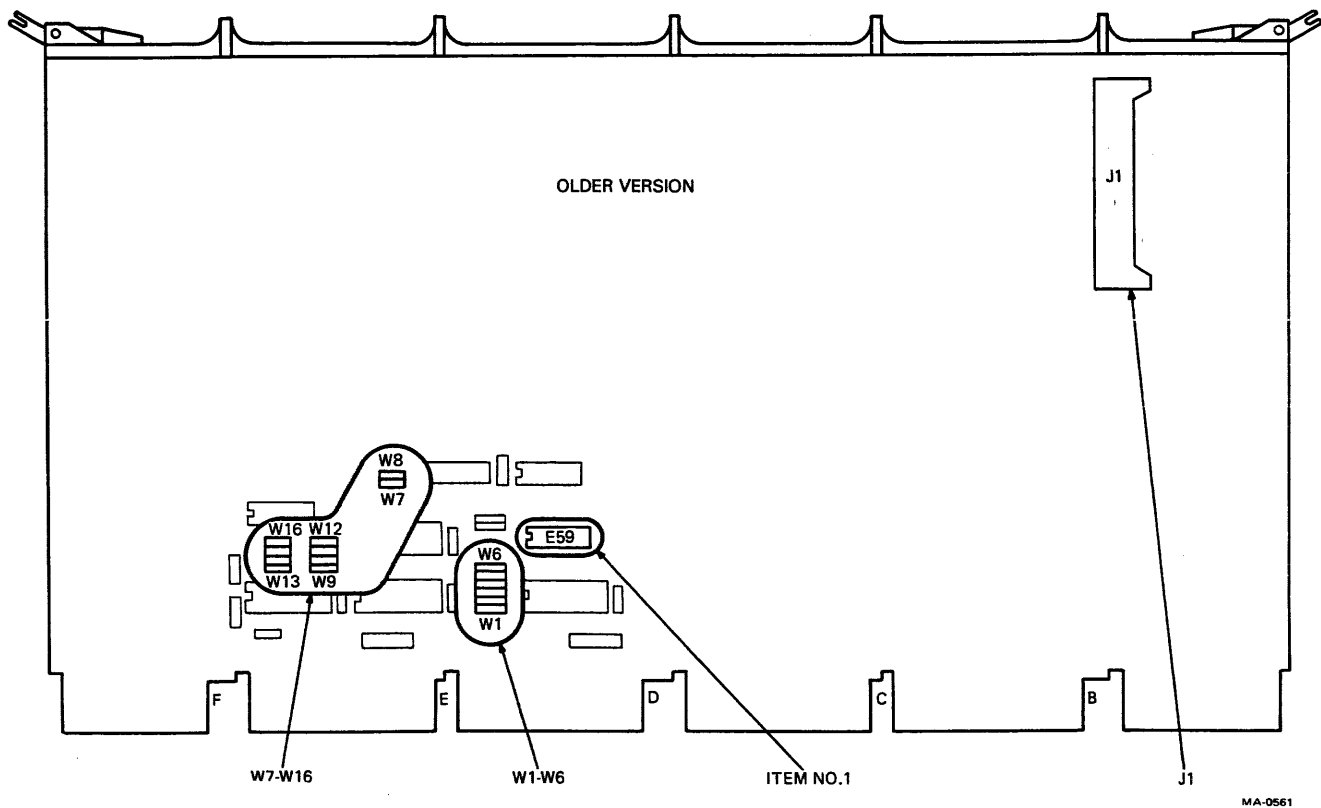

Figure B-9 RL11 Component Layout (Sheet 1 of 2)

Of the 21 jumpers on the RL11 Controller, five are used for factory test purposes. The remaining 16 are for address selection:

W1-W6	VECTOR ADDRESS (160)
W7-W16	BASE ADDRESS (774400)

#### NOTE

A logical 1 is represented by the presence of a jumper wire.

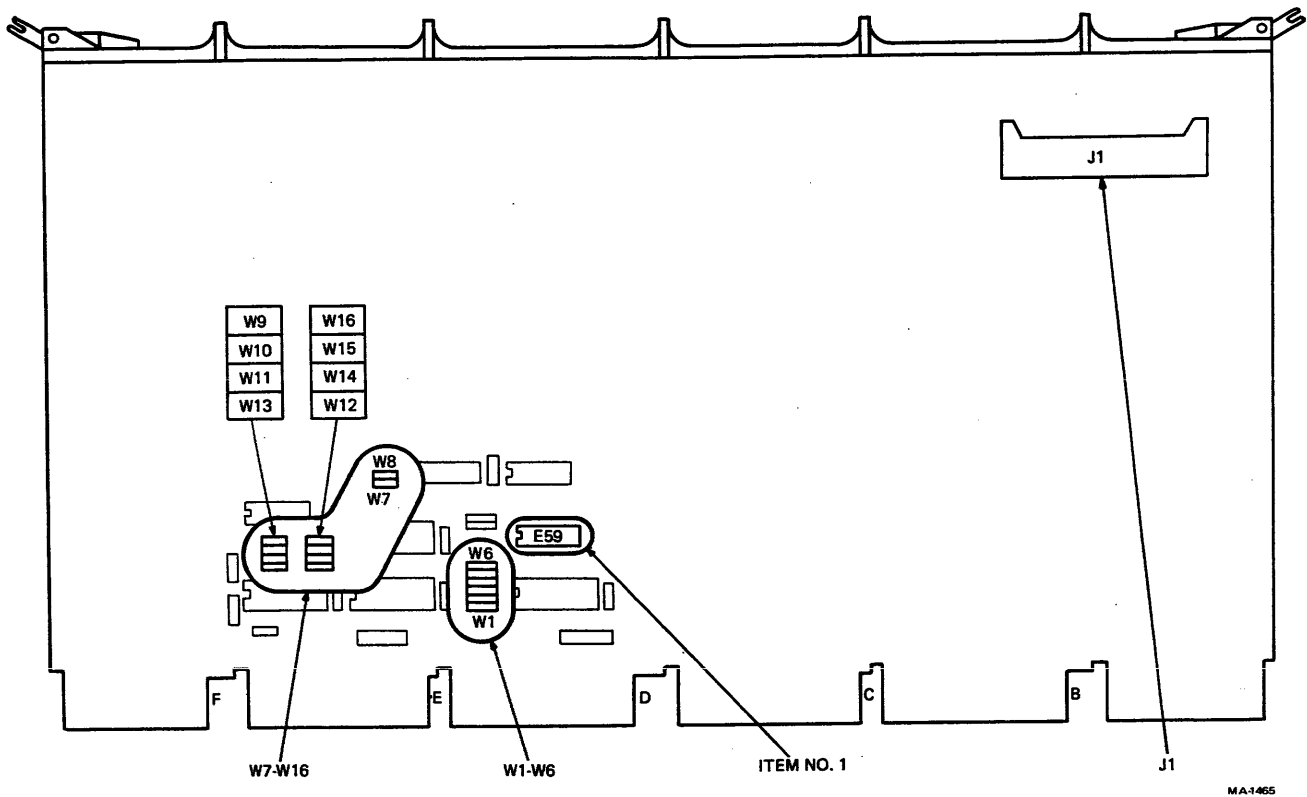

Figure B-9 RL11 Component Layout (Sheet 2 of 2)

The Unibus priority plug sets the priority for bus requests. For the RL11 subsystem, bus requests are at priority level 5 (BR5/BG5). (See Figures B-10 and B-11.)

**NOTE**

**Adjustments on the RL11 are preset at the factory and are not to be changed in the field.**

To install the controller:

1. Remove the M7762 module from its shipping container and examine it for any physical damage.



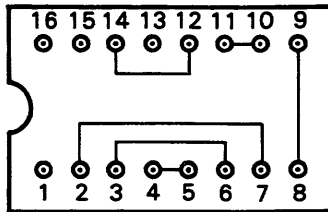

PRIORITY JUMPER PLUG FOR  
BUS REQUEST LEVEL FIVE (5)

PLUG PIN NUMBER	SIGNAL NAME	UNIBUS PIN
1		
2	BG IN	
3	BG OUT	
4	UB BG 4	DT2
5	UB BG 4 IN	DS2
6	UB BG 5	DR2
7	UB BG 5 IN	DP2
8	UB BG 6	DN2
9	UB BG 6 IN	DM2
10	UB BG 7	DL2
11	UB BG 7 IN	DK2
12	BR	
13	UB BR 4	DD2
14	UB BR 5	DE2
15	UB BR 6	DF2
16	UB BR 7	DH2

MA-0560

Figure B-11 RL11 Priority Jumper Assembly Connections

2. If a priority level other than 5 is required, obtain an appropriate priority jumper assembly or set up the priority jumper assembly (item 1, Figure B-9) using Figure B-11 as a guide. The vector and base address jumpers W1-W16 are for 160 and 774400, respectively. If the sub-system configuration requires other than standard addresses, set the jumpers up as shown in Figure B-10. Physical location of these jumpers is shown on Figure B-9.
3. Install the ribbon cable (BC06R-XX) with the red indicator stripe to the right and the smooth side facing the viewer when viewing the component side of the controller as shown in Figure B-12. Dress the cable as necessary.
4. Insert the controller into its appropriate slot in the SPC backplane as shown in Figure B-12 after ensuring that the slot does not contain a grant continuity module in row D. Do not chafe the ribbon cable. Route the cable up and out to the rear of the cabinet, allowing for cable strain relief.



Voltage	Range	Test Point
Ground		AC2
+5Vdc	+4.75 to +5.25 Vdc	AA2
+15 Vdc	+14.25 to +15.75 Vdc	CU1
-15 Vdc	-15.75 to -14.25 Vdc	CB1

Measure all voltages between the ground test point and the appropriate voltage test point. If any adjustments to the power supply are necessary, refer to the appropriate power supply manual.

## **B.5 RLV11 CONTROLLER INSTALLATION**

An RLV11 Controller is comprised of a bus interface module (M8014) and the drive bus module (M8013). Each module has switches, jumpers, trim pots, and connectors that are explained in the following paragraphs.

### **B.5.1 Bus Interface Module**

The bus interface module (M8014) contains the logic circuits that perform the major functions listed below.

- LSI-11 bus interface functions
- Programmable registers
- Silo data storage and control circuits

An illustration of the component side of M8014 is shown in Figure B-13. The location of the bus address switches, the vector address switches, and the connector finger assignments are shown in this figure.

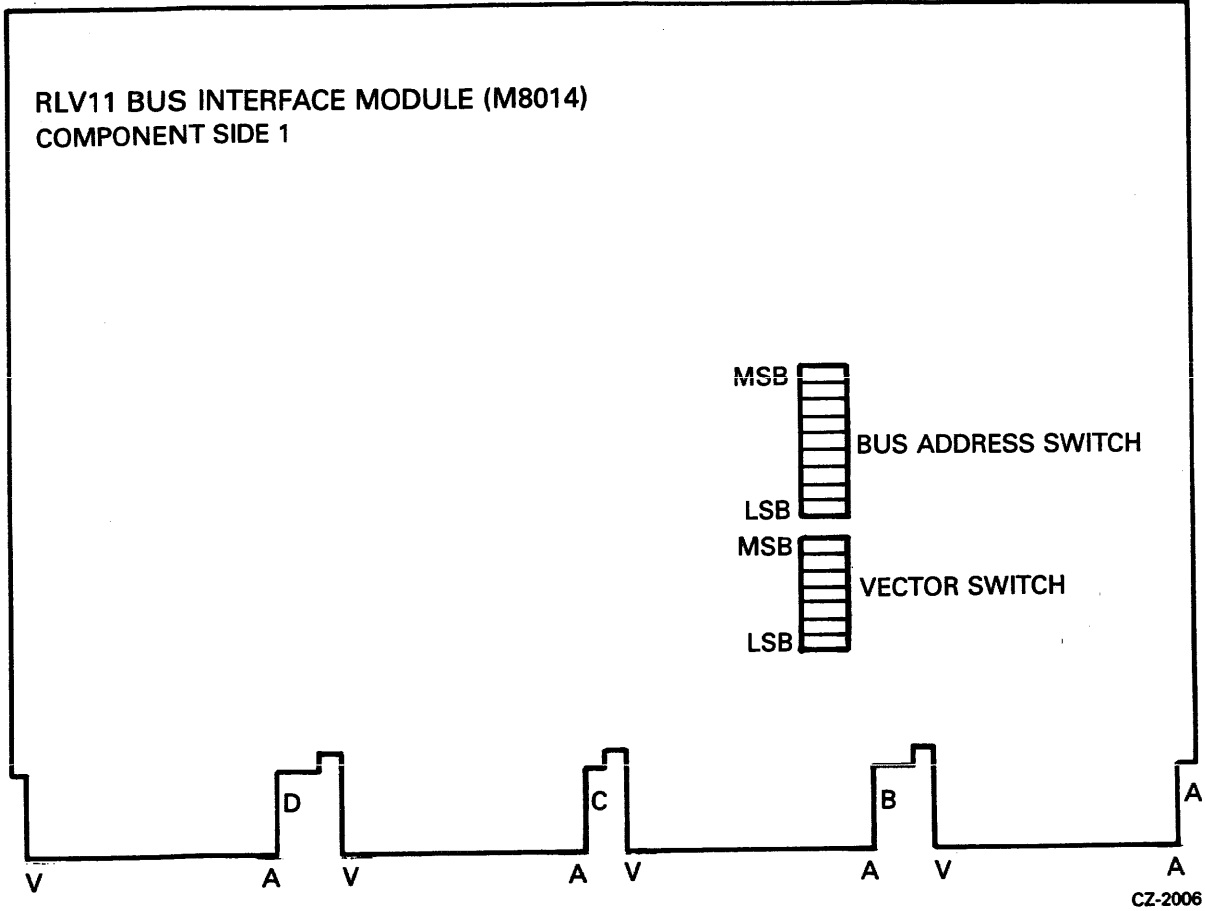
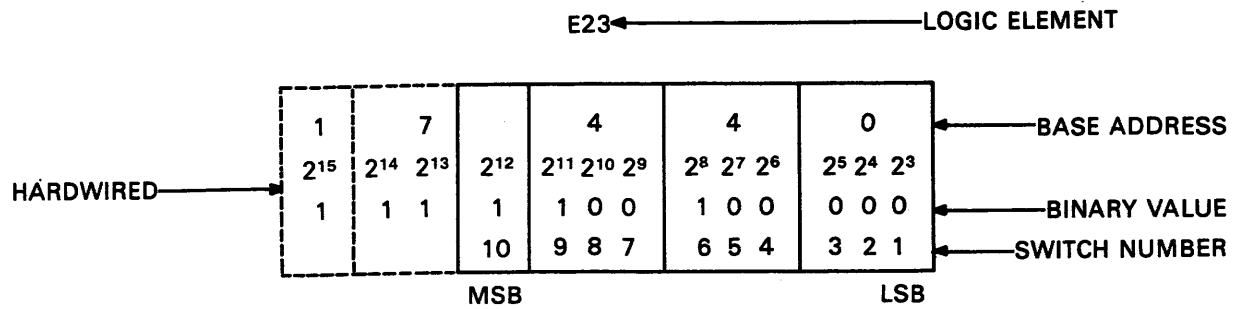

Figure B-13 RLV11 Bus Interface Module (M8014) (Component Side)

The bus address switch is used to set up the device base address. It is normally factory preset to 7440. This means the device CS register has an address of 174400 and the MP register has an address of 174406. The switches have the ON and OFF positions labeled. The ON position is the logical 1 or true state (Figure B-14).



FOR EACH "0" SET THE CORRESPONDING SWITCH "OFF"

FOR EACH "1" SET THE CORRESPONDING SWITCH "ON"

USE THIS SCHEME TO SELECT THE APPROPRIATE BASE ADDRESS IF A DIFFERENT BASE ADDRESS IS REQUIRED

CZ-2034

Figure B-14 RLV11 Base Address Switch Settings

The vector address switch is used to select the address of the vector for this device when it interrupts. It is factory preset for an address of 160 (Figure B-15).

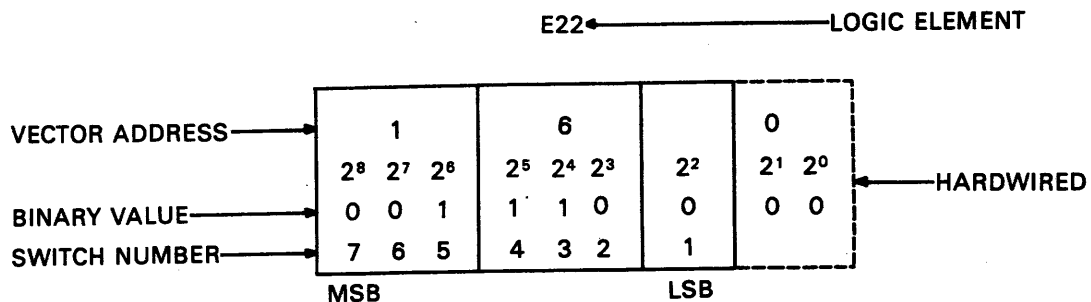

FOR EACH "0" SET THE CORRESPONDING SWITCH "OFF"

FOR EACH "1" SET THE CORRESPONDING SWITCH "ON"

USE THIS SCHEME TO SELECT THE APPROPRIATE VECTOR ADDRESS IF A DIFFERENT VECTOR ADDRESS IS REQUIRED

CZ-2007

Figure B-15 RLV11 Vector Address Switch Settings



### B.5.2 Drive Module

The drive module (M8013) contains the circuitry that performs the major functions listed below.

- Data formatting and error detecting circuits
- Control microsequencer and timing circuits
- Drive bus interface

An illustration of the component side of M8013 is shown in Figure B-16.

#### NOTE

Adjustments to the RLV11 are preset at the factory and are not to be adjusted in the field.

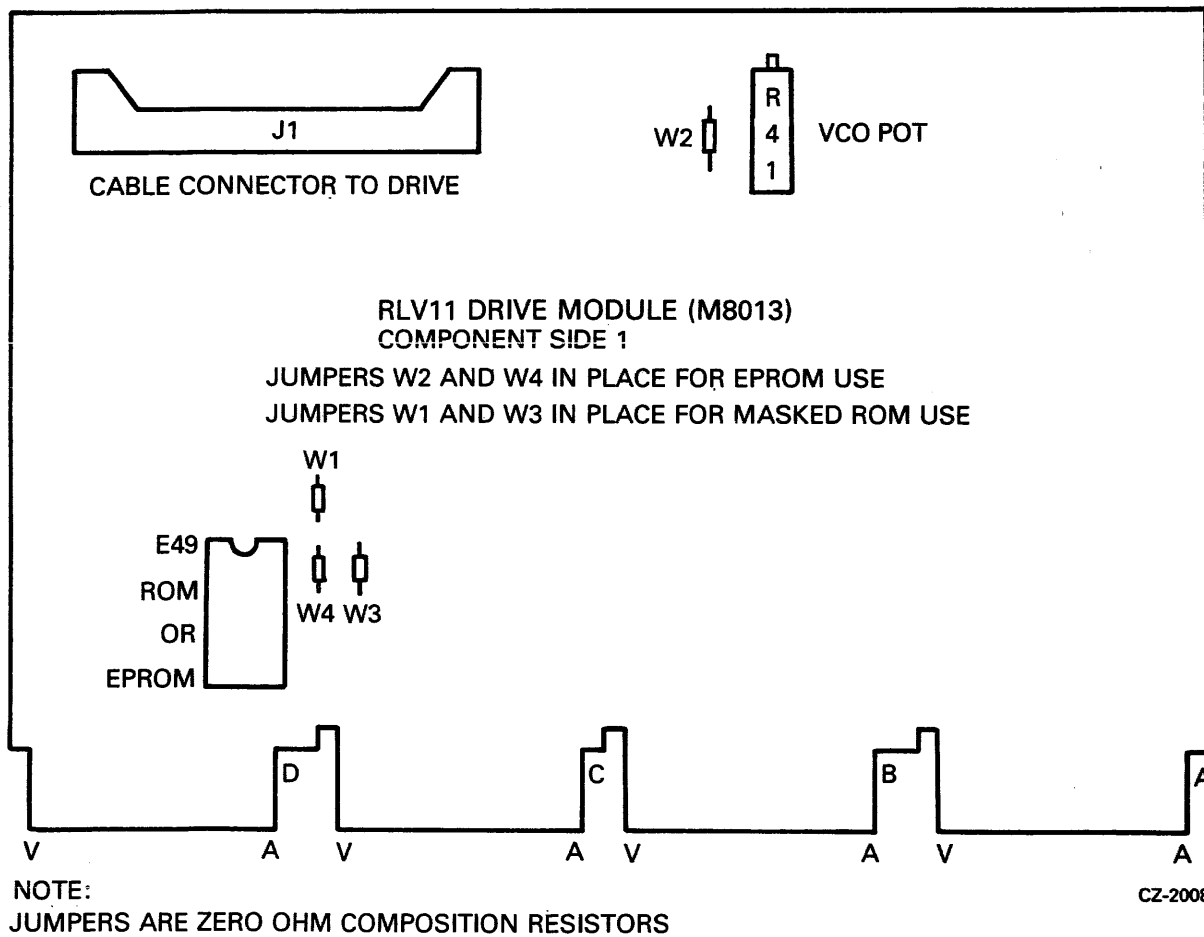
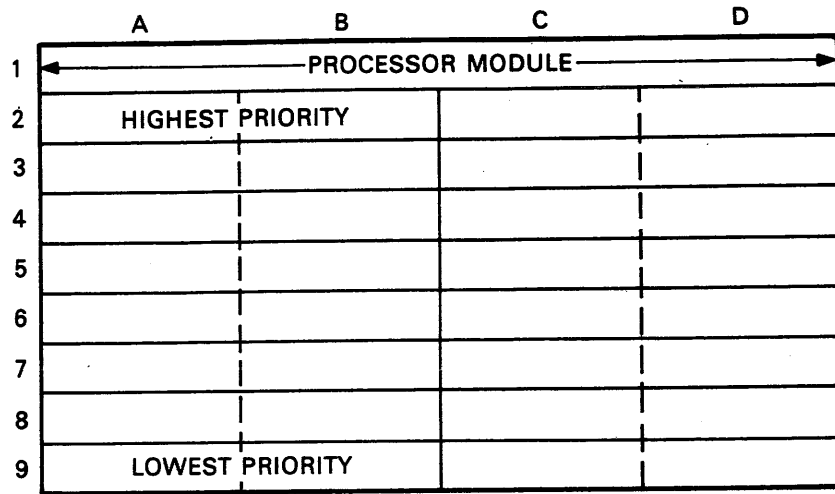

Figure B-16 RLV11 Drive Module (M8013)

### B.5.3 Module Slot Location

Modules M8013 and M8014 must be inserted into the H9273 backplane (Figure B-17) such that the M8013 module is in the slot closest to the processor. Outside of this one restriction, the two modules can be inserted in any two unused slots. The controller priority level is based solely on its electrical distance from the microprocessor module in slot 1.



(MODULE SIDE VIEW OF 9 SLOT BACKPLANE)

MA-0566

Figure B-17 H9273 Backplane Grant Priority Structure

### B.5.4 Module Installation

1. Using the normal configuration rules, select two adjacent slots in the backplane for the two controller modules.
2. Insert the ribbon cable (BC06R-XX) into J1 on the M8013 with the red stripe edge toward the top (Row A) of the module.
3. Insert the M8013 module into the selected slot that is closest to the processor.
4. Examine the M8014 to insure that the base address switches and the vector address switches are set correctly. See Figures B-14, B-15, and B-16.
5. Insert the M8014 module next to the M8013.
6. Install the transition bracket at the rear of the cabinet as shown in Figure B-12. Assemble and install the transition connector.
7. Connect the other end of the ribbon cable with the red stripe up.
8. Apply system power and, using a suitable measuring device (i.e., digital voltmeter or equivalent), verify that the voltages are within the ranges specified below.

Voltage	Range	Test Point
Ground		AC2
+5 Vdc	+4.75 Vdc to +5.25 Vdc	AA2
+12 Vdc	+11.5 Vdc to +12.5 Vdc	AD2
-5 Vdc	-5.25 Vdc to -4.75 Vdc	AL1 (M8013 only)

### NOTE

The  $-5$  Vdc is generated on the M8013 module. It is not adjustable but must be within specifications for proper operation. Module replacement is the only corrective procedure.

Measure all voltages between the ground test point and the appropriate voltage test point. If any adjustments to the power supply are necessary, refer to the appropriate processor's service manual.

## B.6 RLV12 CONTROLLER INSTALLATION

### B.6.1 Introduction

The following paragraphs provide the user or installer with information to correctly configure and install the RLV12 in a 16-, 18-, or 22-bit LSI-11 bus. The user can change the device address, interrupt vector, and memory parity error abort feature.

### B.6.2 Device Address Selection

Software control of the RLV12 is by means of four or five device registers – CSR, BAR, DAR, MPR, and BAE. Four registers are used for 16- or 18-bit addressing; five registers are used for 22-bit addressing. The bus address extension (BAE) register is added for upper address bit selection for 22-bit addressing. The usual device starting address is as follows.

Addressing Mode	Starting Address
16-bit	174400
18-bit	774400
22-bit	17774400

The first register, the CSR, is assigned the starting address and the other registers are assigned the next sequential addresses as shown in Table B-3.

**Table B-3 Address Selection**

	<b>16-bit Addressing</b>	<b>18-bit Addressing</b>	<b>22-bit Addressing</b>
<b>Device Address</b>			
Starting Address Range:	160000– 177770	760000– 777770	17760000– 17777760
Starting Address:	174400	774400	17774400
No. of Registers:	4	4	8 (5 are used; 3 are not)
Registers Used:	CSR (174400) BAR (174402) DAR (174404) MPR (174406)	CSR (774400) BAR (774402) DAR (774404) MPR (774406)	CSR (17774400) BAR (17774402) DAR (17774404) MPR (17774406) BAE (17774410)
Jumpers Used:	Tie M22 (“1”) to: M17, M20, and M21	Tie M22 (“1”) to: M17, M20, and M21	Tie M22 (“1”) to: M17, M20, and M21;  Tie M11 (“X”) to: M12
<b>Interrupt Vector</b>			
Vector Range:	0–774	0–774	0–774
Standard Vector:	160	160	160
Jumpers Used:	Tie M3 (“1”) to: M6, M7, and M8	Tie M3 (“1”) to: M6, M7, and M8	Tie M3 (“1”) to: M6, M7, and M8

The device starting address is selected by jumpers for bits 3 through 12. These jumpers are shown in Figure B-18. A jumper from the selected bit to ground (M22) decodes a 1; no jumper decodes a 0; and a jumper to +5 V (M11) decodes an X (don't care) condition. Figure B-19 shows the RLV12 device starting address format.

**NOTE:**  
 THE MEMORY PARITY ERROR ABORT FEATURE IS AVAILABLE FOR USE WITH MEMORIES THAT HAVE PARITY ERROR CHECKING. THIS FEATURE DOES NOT HAVE TO BE DISABLED FOR MEMORIES THAT DO NOT HAVE PARITY ERROR CHECKING. THE PINS ARE CONNECTED AS FOLLOWS:

CONNECTION	FUNCTION
M23 - M24	NO PARITY
M24 - M25	PARITY ERROR ABORT

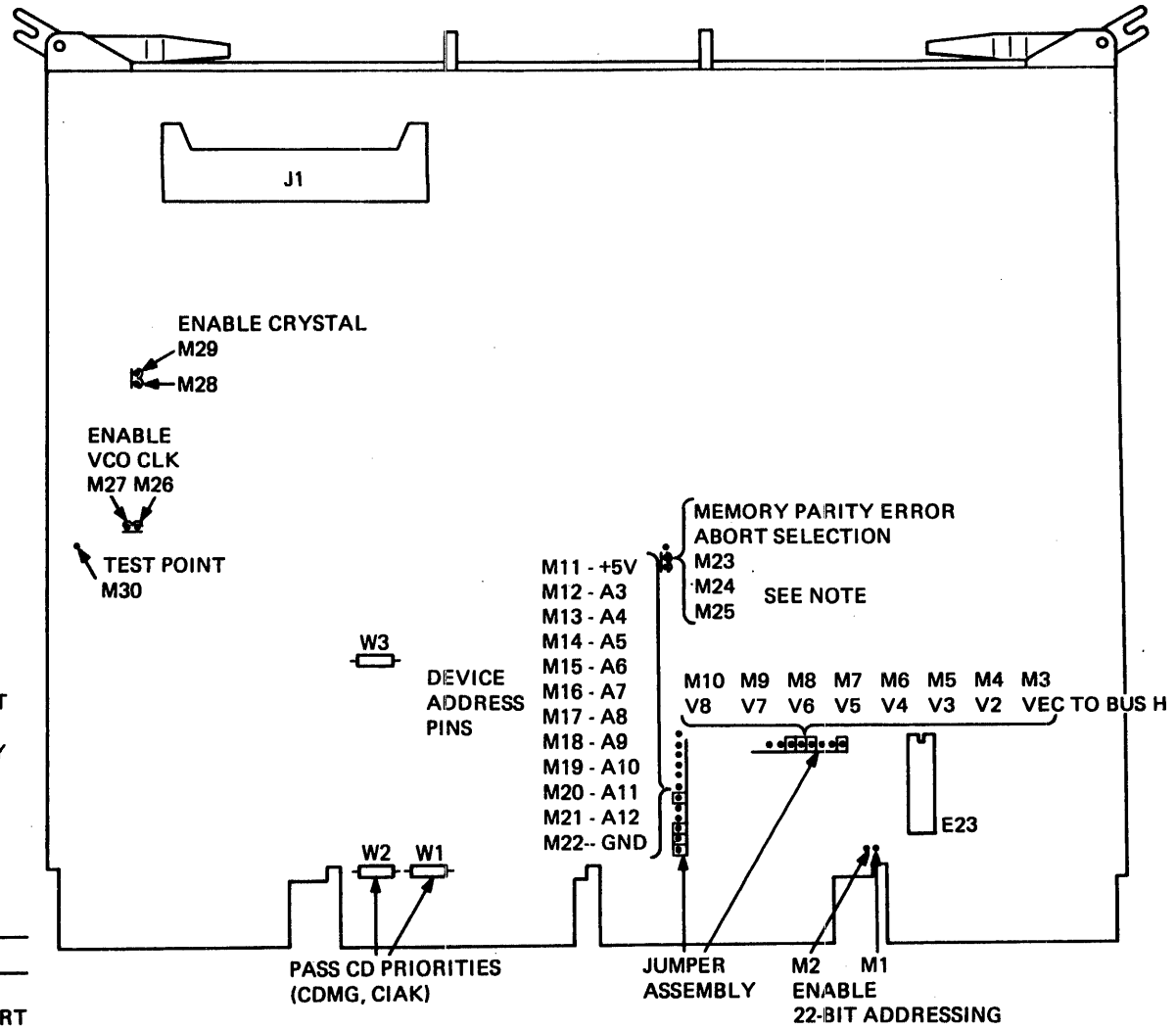
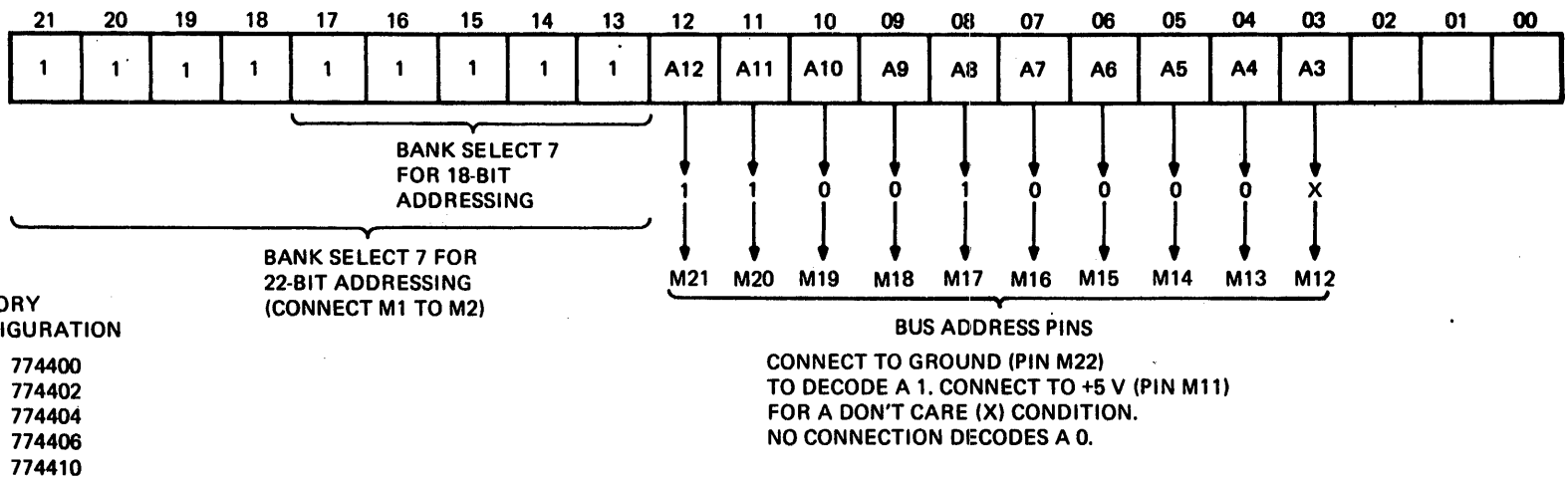

Figure B-18 RLV12 Jumper Locations



MR-5749

Figure B-19 RLV12 Device Address Format

### NOTE

For 22-bit addressing, bit A3 is not decoded in the starting address.

#### B.6.3 Bus Selection

The RLV12 module can be used on 16-, 18-, or 22-bit LSI-11 buses. When sent from the factory, the module operates on 16- or 18-bit buses. To enable the module to operate on a 22-bit extended LSI-11 bus, install jumper M1 to M2, shown in Figure B-18. When installed, the jumper enables bank select 7 (BBS7) to be determined by the upper address bits (13–21). When the jumper is removed, the RLV12 has an 18-bit mode bank select 7 and can replace an existing RLV11 or RLV21 as the disk controller for RL01 and RL02 disk drives.

#### B.6.4 Interrupt Vector

The interrupt vector has a range of 0 to 774. The interrupt vector is preset at the factory to 160. The user may select another vector by changing the jumpers for bits V2–V8, as shown in Figure B-20. A connection to VEC TO BUS H (M3, shown in Figure B-18) generates a 1 for that bit; no connection generates a 0.

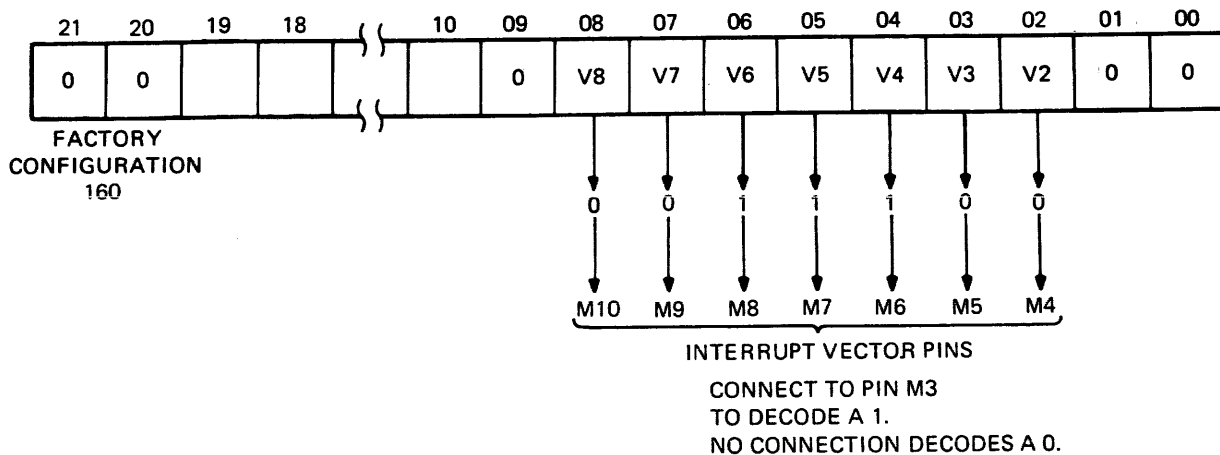

MR-5750

Figure B-20 RLV12 Format Interrupt Vector

#### B.6.5 Interrupt Request Level

The RLV12 interrupts at priority level 4 determined by the interrupt chip E23, a DC003.

#### B.6.6 Memory Parity Error Abort Feature

When reading the system's optional memory with parity error detection, a parity error will set OPI and NXM of the CSR. This is a unique error condition that aborts the current command to the RLV12. This error abort feature is possible only with memories that have parity data bits.

The RLV12 is sent from the factory with the memory parity error abort feature enabled. To disable parity error abort, remove the jumper between pins M24 and M25 and install a jumper between pins M23 and M24 (see Figure B-18). This feature does not have to be disabled for non-parity memories, as parity errors are not generated. Parity error abort uses data bits 16 and 17.

### B.6.7 Other Jumpers

The module has two jumpers, W1 and W2, that enable priority signals to pass on the CD side of the module. The module has these jumpers installed and they should be left in when this controller is installed on the normal LSI-11 bus. If the RLV12 is installed in a C-D interconnect backplane with another module already in place, then these jumpers are removed. If the other module does not use the C-D interconnect scheme, then the status of jumpers W1 and W2 is not important.

Jumper	Signal
W1	CIAKI to CIAKO
W2	CDMG1 to CDMGO

One jumper, W3, enables the word count register to automatically increment during a DMA operation. This jumper is used for factory testing and should be left in.

Two jumpers on the module disable the crystal oscillator and the voltage-controlled oscillator during factory testing. These jumpers should be left in.

Jumper	Oscillator
M26-M27	VCO
M28-M29	Crystal

### B.6.8 Installation

The RLV12 can be installed in any quad LSI-11 bus slot. The controller's priority level is based on its electrical distance from the processor module. Use the following procedure to install the module.

1. Examine the module to make sure that the base address jumpers and vector address jumpers are set correctly. (See Paragraphs B.6.2 and B.6.4.)
2. Check jumpers M1 and M2 for enabling the correct bank select 7 (BBS7) for the 18- or 22-bit LSI-11 bus.
3. If desired, disable the memory parity error abort feature. This feature can only be used with system memories that have parity options, but this feature does not have to be disabled for non-parity memories. (See Paragraph B.6.6.)
4. Insert the BC80M controller cable into J1 on the M8061.
5. Insert the M8061 in the selected slot in the LSI-11 bus.
6. Connect the other end of the BC80M cable to the drive.
7. Continue with the disk installation. (Refer to Paragraph B.8.)



### **B.6.9 Acceptance Testing**

The RLV12 controller is tested by running the RLV12 diskless diagnostic test and, if a drive is attached, by running the diagnostics that exercise the RL01 and RL02 disk drive. The diskless diagnostic should be run first. The RLV12 diagnostics are available on different media. Contact your local DIGITAL sales office for the types of media available and their part numbers.

Run the XXDP+ diagnostics in the following order.

1. CVRLB RLV12 Diskless Diagnostic (16-, 18-, or 22-bit mode)
2. CZRLG Controller Test Part 1
3. CZRLH Controller Test Part 2
4. CXRLI Drive Test Part 1
5. CZRLJ Drive Test Part 2
6. CZRLN Drive Test Part 3
7. CZRLK Performance Exerciser
8. CZRLL Compatibility Test
9. CZRLM Bad Sector File Utility

#### **NOTE**

**The Bad Sector File Utility is not a diagnostic test. It is used by Field Service personnel to examine the bad sector file on the disk and to write entries into that file.**

## **B.7 RL8A CONTROLLER INSTALLATION**

### **B.7.1 Introduction**

The RL8A Omnibus controller module (M8433) contains the logic functions listed below.

- Interface logic
- Programmable registers
- Silo data storage and control
- Data formatting and error detection
- Control microsequencer and timing logic
- Drive bus interface logic

#### **NOTE**

**Adjustments on the RL8A are preset at the factory and are not to be changed in the field.**

### **B.7.2 Module Slot Location**

The module can be inserted into any unused OMNIBUS hex-height slot between the CPU and the first memory element. The controller is connected to the first drive via a BC80J-20 interface cable. Connections between drives are made using a BC20J-XX (70-12122-10) cable.

### **B.7.3 Module Installation**

1. Remove the M8433 module (see Figure B-18) and interface cable (BC80J-20) from the shipping container and inspect them for physical damage.
2. Verify the proper jumper configuration for device codes and priority (Figure B-21).

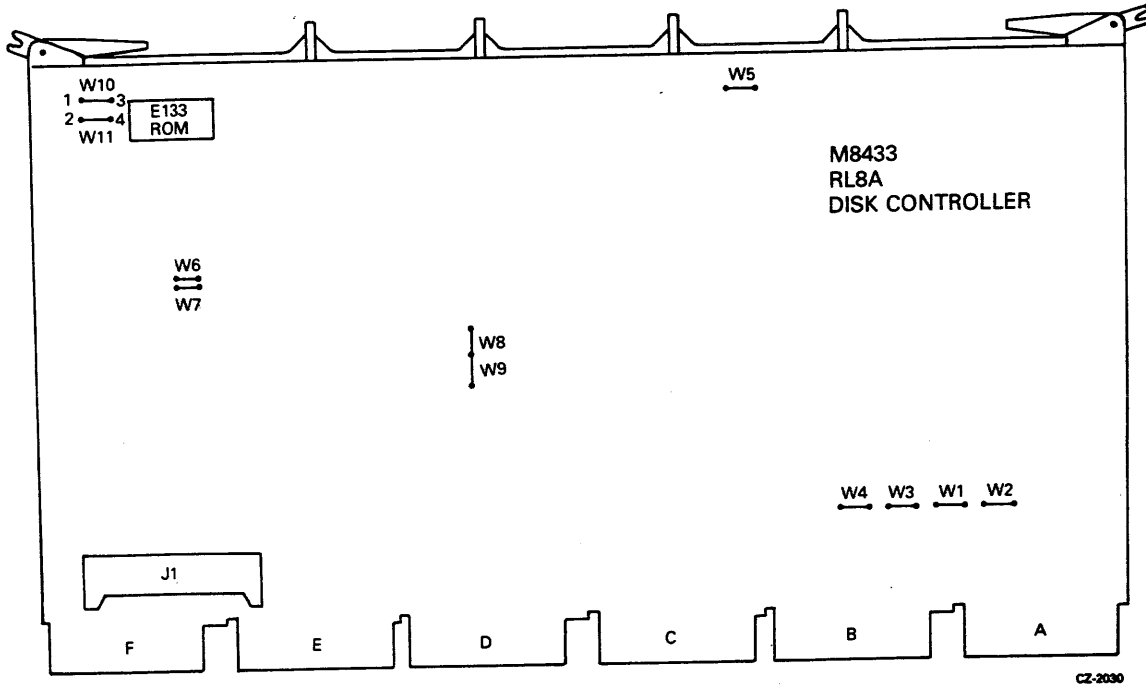

Figure B-21 RL8A Jumpers

Device Code	W1	W2
60,61	IN	OUT
62,63	IN	IN

Break Priority	W3	W4	W5
0	IN	OUT	IN
1	OUT	IN	OUT

**NOTE**

RL8A is shipped from the factory with a priority of 0.

Device Type	W8	W9
RL01	OUT	IN
RL02	IN	OUT

ROM Type (E133)	W10	W11	W6	W7
012E2	OUT	IN	IN	OUT
8708 or 2708	IN	OUT	OUT	IN

3. Position the BC80J-20 interface-to-drive cable in the PDP-8 chassis and connect the Berg connector to the M8344 module.
4. Install the M8344 module into selected slot in the OMNIBUS backplane.
5. Route the cable out to where the first drive will be installed.

## B.8 RL01/RL02 DISK DRIVE INSTALLATION

### B.8.1 Unpacking and Inspection

1. When delivered, each drive and its associated cabinetry is enclosed by a heavy cardboard carton. If the drive is shipped with a system and mounted in a cabinet, then the carton is attached to a shipping skid (Figure B-22). Remove the plastic straps that secure the shipping carton to the skid.

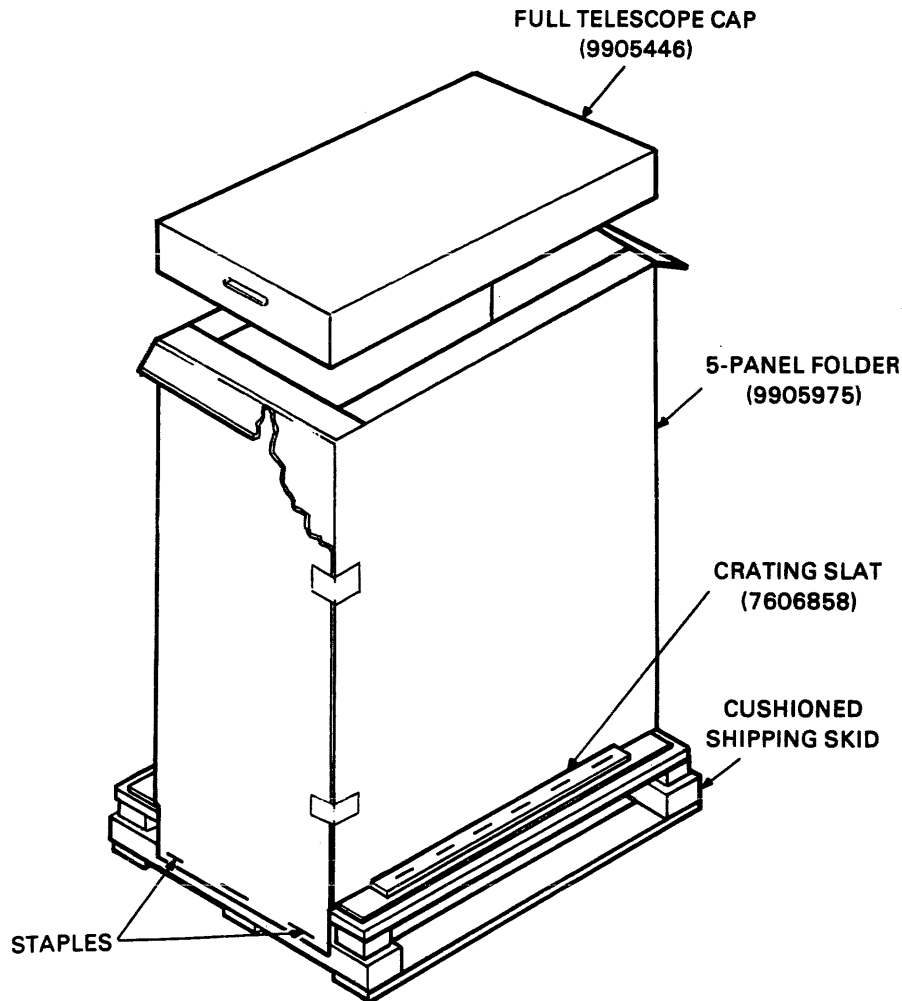

11-4979

Figure B-22 H950 Shipping Package

2. Remove the lid from the top of the carton.
3. Remove the staples that fasten the wooden crating slats and carton flanges to the skid.
4. Remove the shipping carton.
5. Inspect the cabinet and drive for signs of damage. Retain all packing material and receipts in the event that any claims for shipping damage must be filed. All claims should be filed promptly with the transportation company.

### **B.8.2 RL01/RL02 Disk Drive Unit Mounting**

#### **NOTE**

**If the RL01/RL02 is to be mounted in an H950 cabinet, the shipping brackets must be retained and re-fitted after installation. This is the only way to prevent the drive from sliding while repositioning or moving the H950 cabinet.**

The drive may be shipped in a rack or cabinet as an integral part of a system or may be shipped in a separate container for addition to an existing system.

If the drive is to be installed in an existing rack or cabinet, install the chassis slides first as described in Steps 1 through 6 below (Figure B-23). The procedure for installing the drive itself begins with Step 7.

1. Install cabinet stabilizers before mounting the drive.
2. Remove the slides from the carton. (Retain the hardware for reassembly.)
3. Install slides into the rack or cabinet using enclosed hardware. Be sure the slides are at the correct height to permit installation of pop panels (dress panels) upon completion of installation. Also verify that the slides do not bind on any hardware used to mount the slide.
4. Extend slides to lock position.
5. Slide drive onto chassis slides and reinstall mounting hardware.
  - a. Figure B-23 shows the relationship between the drive, slide mounting rails, and slides. Note first the position of the slide mounting rails. These rails are currently riveted to the sides of the drive.
  - b. The cabinet slides fit under the edge of the mounting rails. The forward edge of the mounting rails are curved to grip the curled edge of the slides (see Figure B-23a, B-23b and detailed view A.)
  - c. At the rear of each slide is a locking tab that grips the top rear edge of the rail (Figure B-23b).
  - d. The drive should be carefully placed on top of the slides hooking the front and rear of each slide as previously described.
  - e. When properly placed, the locking latch (Figure B-23b) on each mounting rail drops into a groove on each slide. This holds the drive securely so that the screws may be inserted to bolt the front of each slide to the drive (Figure B-23b).

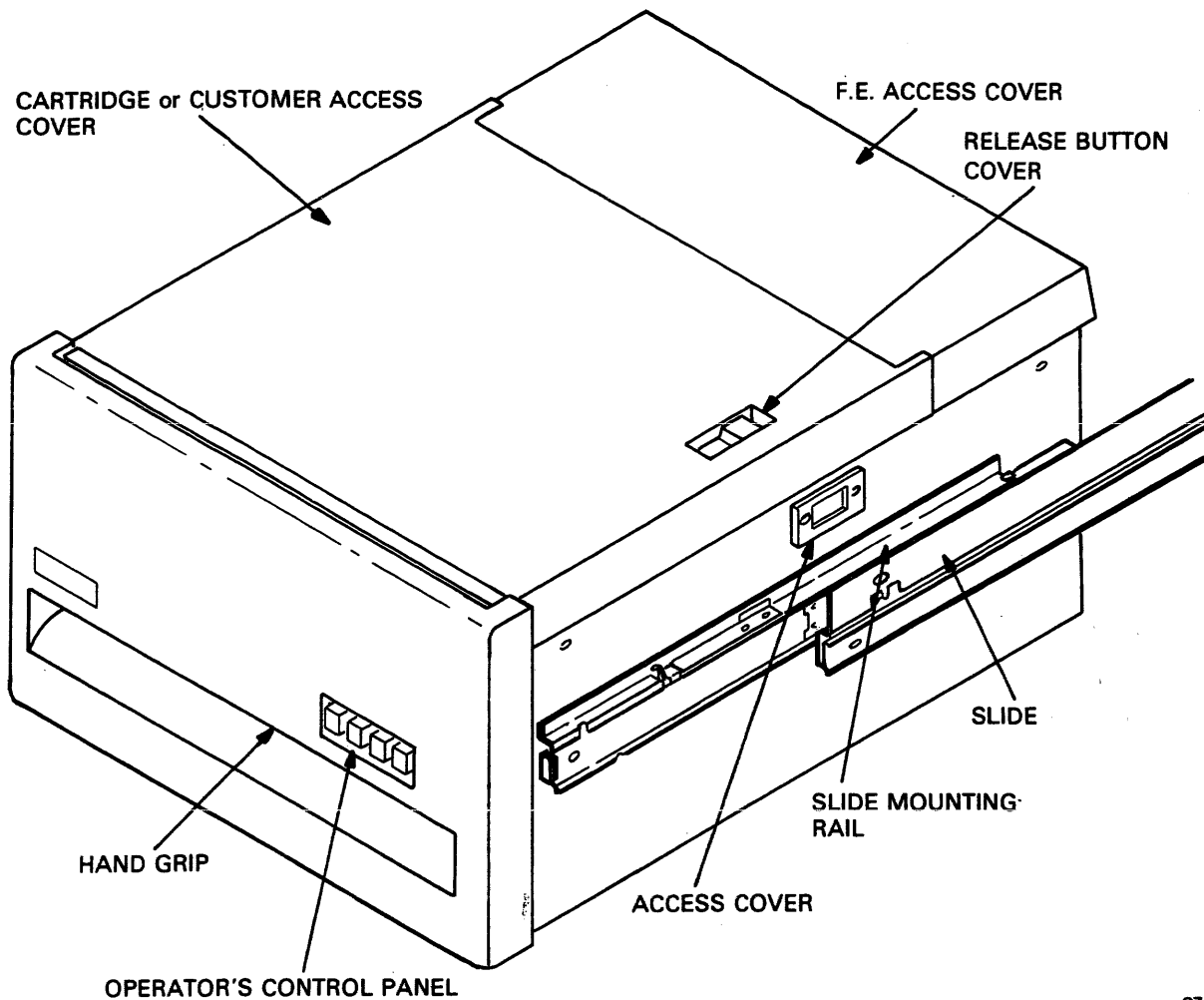

CZ-0502

Figure B-23a RL01/RL02 Cabinet Installation

- f. After bolting the front of each slide, adjust the length of the slide (using the slide extension release catch) so that the rear slide screw may be inserted (Figure B-23b).
6. Ensure that the disk drive moves easily on the slides, that there is no binding in the cabinet, and that the proper height has been maintained for dress panels.

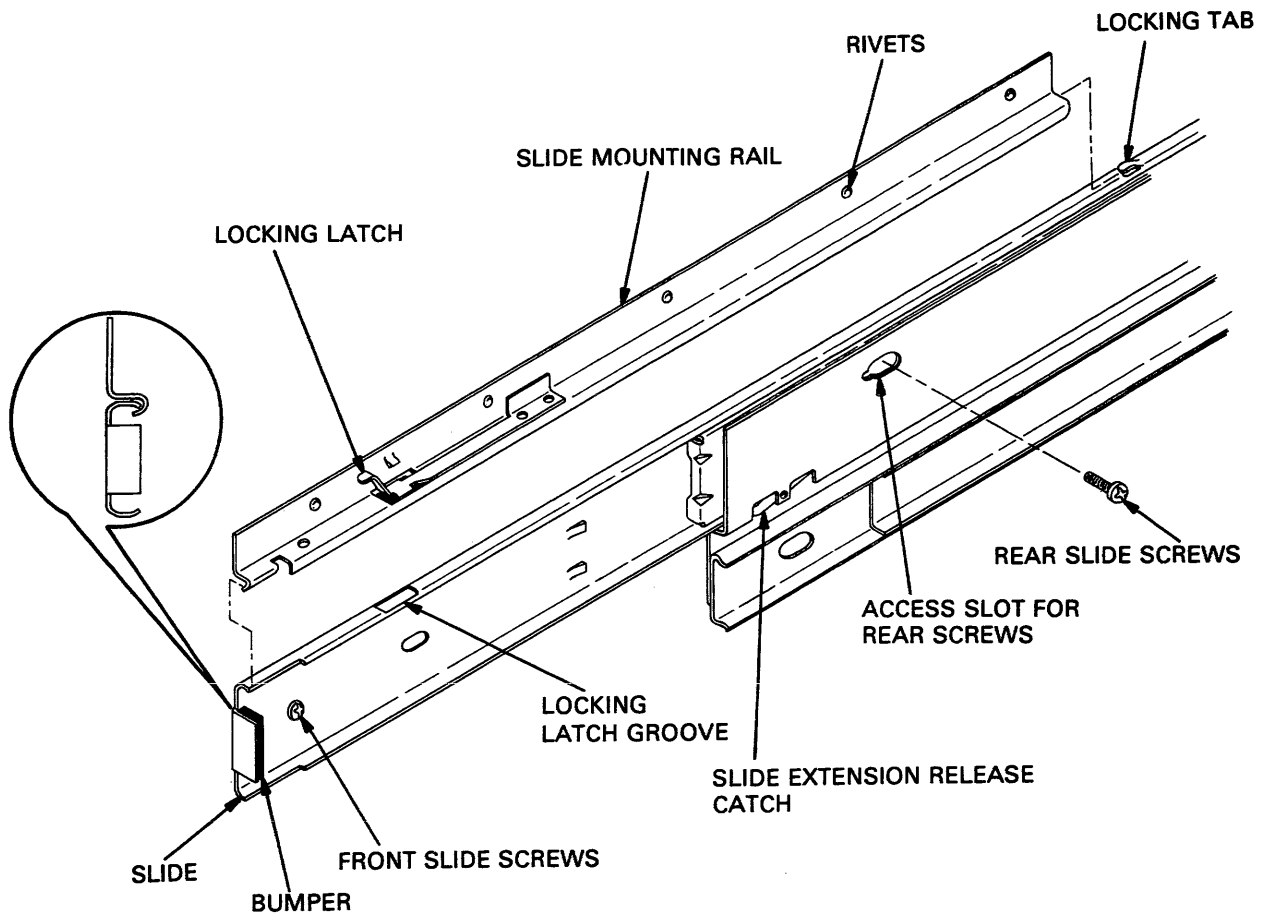

CZ-0503

Figure B-23b RL01/RL02 Cabinet Installation

7. Open the drive access cover by loosening the four captive fasteners holding the module access cover. When the screws are sufficiently loosened to raise the cover, the drive access cover may then be lifted off the drive. The module access cover may be rested on the rear lip of the drive (Figure B-24).

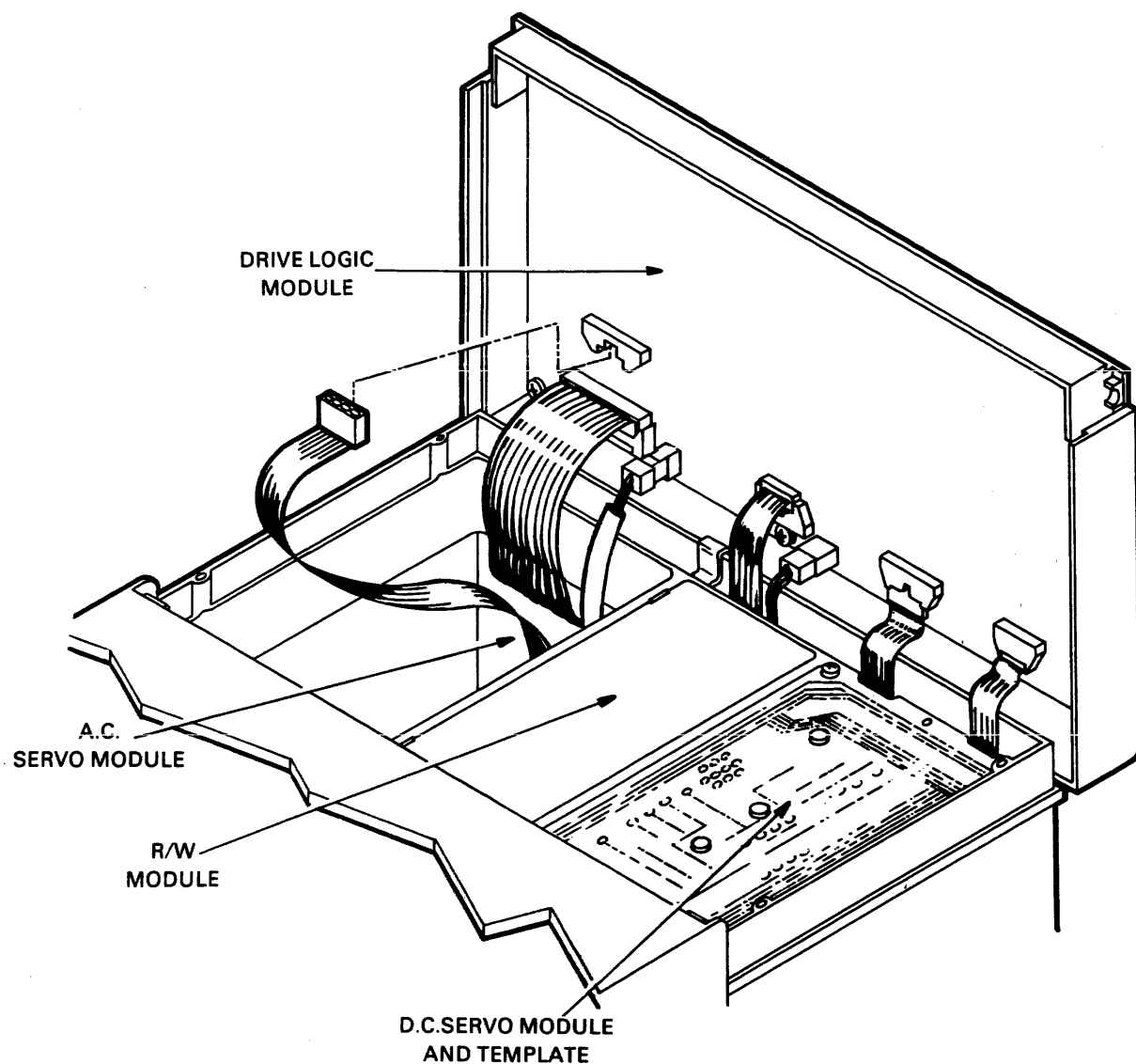

MA-0564

Figure B-24 RL01/RL02 Disk Drive —  
Exposed Drive Logic Module

8. Loosen the head restraining bracket screw located on the positioner. Turn the bracket 90 degrees and retighten the screw (Figure B-25).
9. On newer drives, there are two shipping screws on the bottom of the unit that secure the spindle/blower motor. Remove the screws.
10. If the drive is being installed in a dual-drive cabinet that has an interlock system to prevent more than one drive being extended at a time, ensure that it is connected.
11. Inspect the terminal block covers at the rear of the drive. Ensure that they are configured properly for the input power available (Figure B-22).

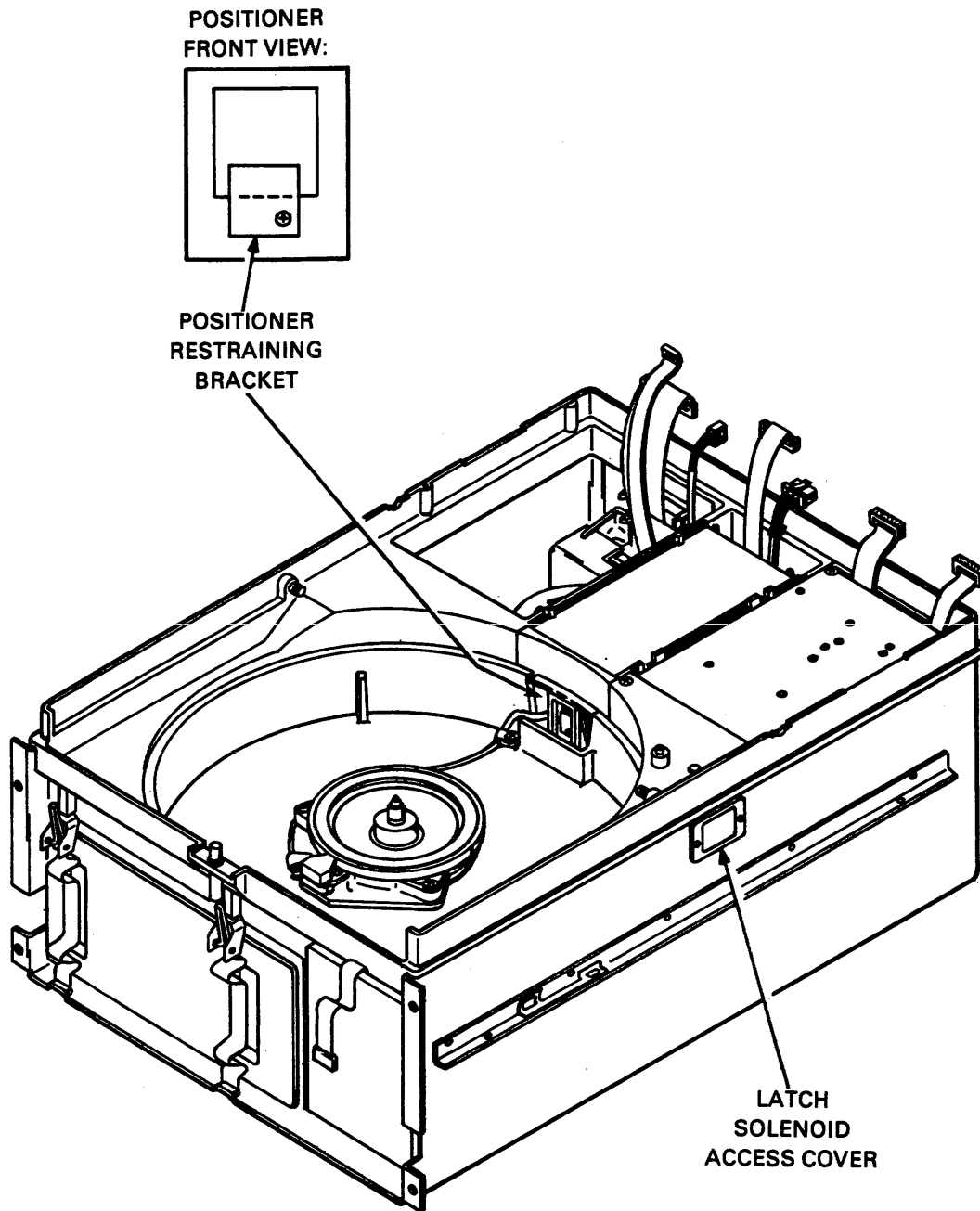

CZ-2003

Figure B-25 RL01/RL02 — Covers Removed

**CAUTION**

**Connection to the wrong power source will result in serious damage to the disk drive.**

12. If there is only one disk drive in the system, or if this is the last drive of the daisy-chain, install a terminator assembly (DIGITAL part no. 70-12293) in the "cable out" location at the rear of the drive (Figure B-26).



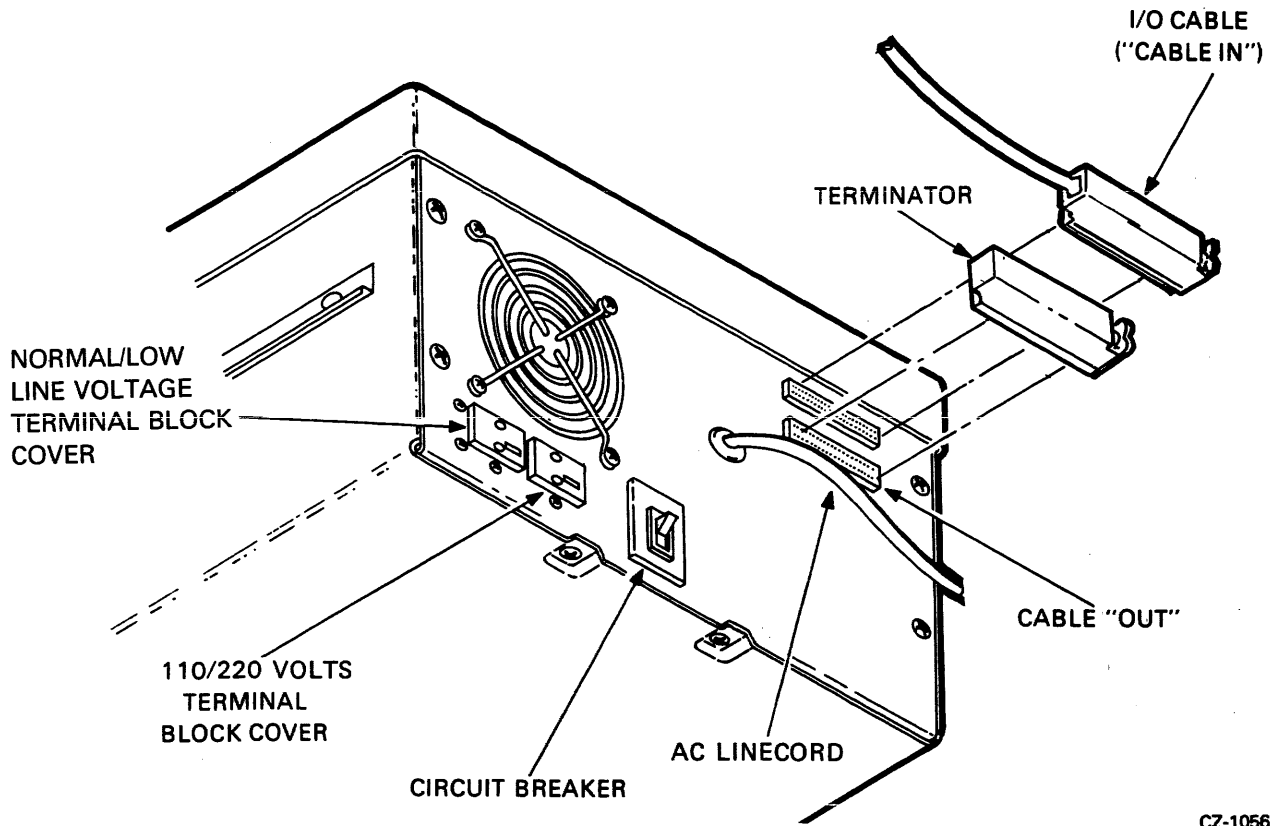

Figure B-26 RL01/RL02 Disk Drive — Rear View

**NOTE**

**On newer-drives, a shielded cable is used. Its part number is BC21Z-XX.**

13. If this is an RL11- or an RLV11-based system, route the I/O cable BC20J-XX (DIGITAL part no. 70-12122-10) between the first drive and the transition connector. If this is an RL8A-based system, route the BC80J-20 cable from the RL8A to the first drive. If this is an RLV12 based system, route the BC80M-6 between the RLV12 and the first drive.
14. If this is a multidrive installation, connect an I/O cable from "cable in" of this drive to the "cable out" connector of the previous drive. Repeat for each drive.

**NOTE**

**The total length of cable from controller to the last drive must not exceed 30 m (100 ft).**

15. Install the proper unit select plug at the front of the drive (Figure B-27).

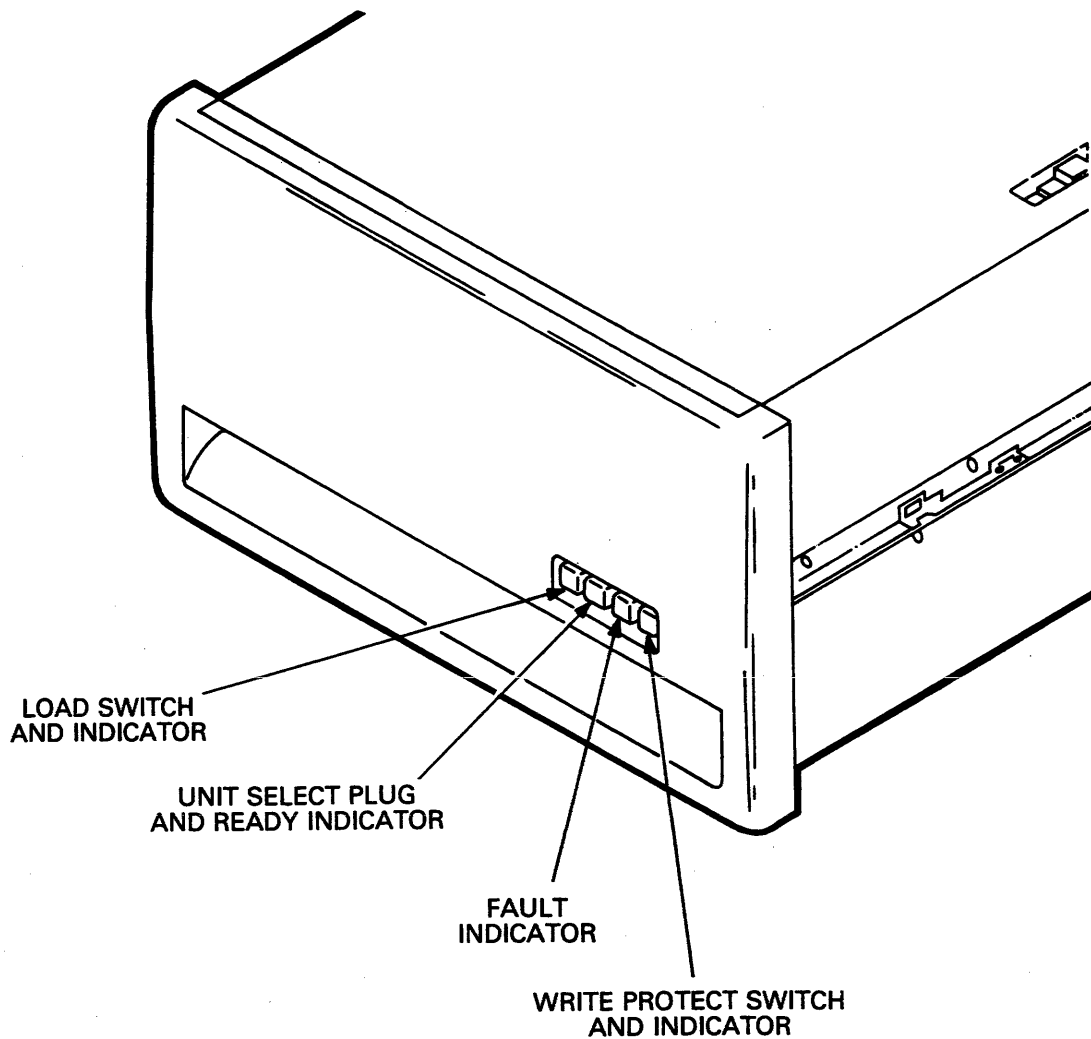

CZ-1005

Figure B-27 RL01/RL02 Disk Drive — Front View

### B.8.3 Drive Prestart-up Inspection

To begin the inspection procedure, remove the top cover by loosening the captive screws and lifting the cover straight up. Rest the cover on the rear of the drive. With the drive power off, follow these steps.

1. Ensure that the positioner restraining bracket is secured out of position to prevent interference with the positioner (Figure B-25).
2. Ensure that the positioner is home.
3. Ensure that the read/write head gimbels are not bent or dirty. (If they are dirty, clean with a solution of 91 percent alcohol and 9 percent water and a lint-free wiper.)
4. Ensure that the spindle rotates freely and its top surfaces are not dirty. (Clean as described above.)
5. Ensure that the brush assembly is home (not exposed).

#### NOTE

An engineering change has eliminated the need for brushes on the drive. On newer RL01 and RL02 drives, the brush assembly has been replaced with a unit containing only the cartridge-in-place and top cover interlock. The drive logic module also contains some logic changes to accommodate the brush cycle removal.

6. Ensure that the logic modules and connectors are seated firmly.
7. Turn CB1 ON.
8. Ensure that the spindle rotates slowly counterclockwise for approximately 15 seconds and stops. At this time, the LOAD light will come on.

#### NOTE

On the newer drives (without brushes), the spindle will NOT rotate until both the top cover and the cartridge-in-place interlocks are depressed.

9. Ensure that the FAULT light is not on.
10. Ensure that the cooling fan at the rear of the drive is operating.
11. On the newer drives, release the top cover and cartridge-in-place interlocks, noting that the spindle stops rotating.
12. Using a suitable measuring device (i.e., digital voltmeter or equivalent), ensure the following drive voltages are within the specified tolerances.

Voltage	Range	Test Point
+15 UNREG	(+15.0 to +18.0 Vdc)	+V UNREG
-15 UNREG	(-15.0 to -18.0 Vdc)	-V UNREG
+5 REG	(+4.48 to +5.1 Vdc)	TP8
+8 REG	(+7.7 to +8.3 Vdc)	TP4
-8 REG	(-7.7 to -8.3 Vdc)	TP5

See Figure B-24 for dc servo module location. Test points are located on the mask covering the dc servo module.

12. Verify that the WRITE PROTECT switch cycles in and out and the indicator lights up when the switch is pressed.
13. Verify that the LOAD switch cycles in and out and the indicator light goes out when the switch is pressed. Return switch to the "out" position.
14. Turn off CB1.
15. Reinstall the top cover and secure with the captive screws.

16. Ensure that the drive access cover cannot be opened.
17. Turn CB1 on and ensure the drive access cover will open.

#### **B.8.4 Drive Start-up Operation Check**

1. With the drive power ON, install a scratch cartridge.
2. Close the cover, press the LOAD switch and note that:
  - The LOAD light goes out
  - When the cartridge reaches nominal speed (after approximately 30 seconds), a brush cycle commences on those drives that have brushes. When the brushes have returned home, the read/write heads load and approach cylinder 0. When the heads have locked onto cylinder 0, the READY light illuminates. The total time for this process is approximately 45 seconds.
3. Press the LOAD switch again. The READY light should go off and the read/write heads should retract to their home position. The spindle should slow down and then come to a complete stop after about 30 seconds. The LOAD light illuminates when the spindle stops.
4. If the drive start-up operation check detailed above is successfully completed (i.e., the READY indicator illuminates), run the subsystem confidence tests described in Paragraph B.8.

#### **B.9 CONFIDENCE TESTING**

Confidence testing consists of running the diagnostic programs. Each diagnostic has a listing that contains operating instructions. Each listing explains system hardware requirements, software environment, which features are tested and how they are tested, program options and how to select them, how to interpret printouts, error handling, device information tables, dialogue with the Diagnostic Supervisor, and complete operating instructions. The listings are available as hard copy printouts or on microfiche.

The binary form of the diagnostic programs is available on various media. It is always advisable to keep a copy of the RL01/RL02 diagnostics on a media other than the RL01K or RL02K cartridge so that the diagnostics can be loaded through another device if the RL subsystem is down.

The old MAINDEC naming system is replaced with a new naming system. Manual and microfiche designations are also converted. In addition, part numbers are assigned that conform to DIGITAL's standard twelve character part number system.

When ordering diagnostic media, listings, manuals, or microfiche, check the current catalog or index for the latest designation and revision level. The applicable catalogs and indexes are listed in Table B-4. Unless otherwise specified when ordering, the latest revision will be shipped.

**Table B-4 Diagnostic Catalogs and Indexes**

---

<b>Name</b>	<b>Part Number</b>
PDP-11 Diagnostic Software Components Catalogue*	AV-B021E-TC
PDP-8 Software Components Catalogue*	AV-0872B-TA
PDP-11 Maindec Index (microfiche)	AH-9026P-MC
PDP-8 Maindec Index (microfiche)	AH-6572G-MA

---

\* Both of these catalogs are available on microfiche (EP-08/11)

**B.9.1 RL11-Based Diagnostics**

The diagnostic package used for an RL11/RL01 subsystem before the release of the RL02 consisted of the six free-standing programs listed in Table B-5. There were two revisions, Revision A and Revision B. These programs handled only RL01 drives (not RL02 units).

**Table B-5 RL11 Based Diagnostics**

---

<b>Part Number</b>	<b>Description</b>
CZRLAA0	Controller Test Part 1
CZRLBA0	Controller Test Part 2
CZRLCA0	Drive Test Part 1
CZRLDA0	Drive Test Part 2
CZRLEA0	Performance Exerciser
CZRLFA0	Drive Compatibility Test

---

These diagnostics can be run free-standing under the Diagnostic Supervisor, manually under XXDP, chainable under XXDP (except CZRLFA0 which requires manual intervention), or under manufacturing checkout environments such as SLIDE or ACT-11.

A new diagnostic package is available to test either an RL01 or an RL02 unit. The kit numbers are listed in Table B-6 and the contents of the tests are shown in Table B-7.

**Table B-6 RL11 Diagnostic Kit Numbers**

---

<b>Part Number</b>	<b>Description</b>
ZJ283-RB	Documentation and paper tape
ZJ283-RZ	Documentation only
ZJ283-PB	Paper tape only
ZJ283-FR	Microfiche only

---

**Table B-7 RL11 Diagnostic Components**

<b>Part Number</b>	<b>Name</b>	<b>Item</b>
AC-F111A-MC AH-F110A-MC AK-F108A-MC AK-F109A-MC AF-F111A-M0	CZRLGA0 Controller Test #1	Documentation Fiche Paper tape #1 Paper tape #2 DECO
AC-F115A-MC AH-F114A-MC AK-F112A-MC AK-F113A-MC AF-F115A-M0	CZRLHA0 Controller Test #2	Documentation Fiche Paper tape #1 Paper tape #2 DECO
AC-F119A-MC AH-F118A-MC AK-F116A-MC AK-F117A-MC AF-F119A-M0	CZRLIA0 Drive Test #1	Documentation Fiche Paper tape #1 Paper tape #2 DECO
AC-F123A-MC AH-F122A-MC AK-F120A-MC AK-F121A-MC AF-F123A-M0	CZRLJA0 Drive Test #2	Documentation Fiche Paper tape #1 Paper tape #2 DECO
AC-F127A-MC AH-F126A-MC AK-F124A-MC AK-F125A-MC AF-F127A-M0	CZRLKA0 Performance Exerciser	Documentation Fiche Paper tape #1 Paper tape #2 DECO
AC-F131A-MC AH-F130A-MC AK-F128A-MC AK-F129A-MC AF-F131A-M0	CZRLLA0 Drive Compatibility Test	Documentation Fiche Paper tape #1 Paper tape #2 DECO
AC-F135A-MC AH-F134A-MC AK-F132A-MC AK-F133A-MC AF-F135A-M0	CZRLMA0 Bad Sector File Utility	Documentation Fiche Paper tape #1 Paper tape #2 DECO

There is an additional program added to the package named CZRLMA0. It is used to read the Bad Sector File and can be used to write entries into the field writable portion of the Bad Sector File. This program is not a diagnostic and should not be used as one. It assumes that the system is functioning properly.

In addition to the free-standing diagnostics, there is a DECX11 module for use with the DECX11 System Exerciser. The current revision is designated RLAA and is in DECX11 Option Library #5 DXQLQ. Revision A (RLAA) will operate an RL01 drive only. Revision B (RLAB) will operate either an RL01 or an RL02.

There is also an RL subsystem driver for the Maintenance Program Generator (MPG).

The binary form of the diagnostics is included as part of XXDP. This makes it available on media for the RK05, RK06, RK07, RL01, RX01, DECTape, magnetic tape, and DECassette.

The use of XXDP, DECX11, and MPG is explained in the manuals listed in Table B-8.

**Table B-8 User Documents**

Part Number Hard Copy	Part Number Microfiche	Name
AC-9093I-MC	EP-DZQXA-J-D	CZQXAI0 XXDP User Guide
AC-8240Z-MC	AH-8242Z-MC	CXQBAZ0 DECX11 User Document
AC-816JC-MC	EP-DTUMA-C-D	CTUMAC0 M.P.G. User Manual

**B.9.2 RLV11-/RLV12-Based Diagnostics**

The RLV11/RLV12 controller-based subsystems are tested with the same set of diagnostics as RL11 controller subsystems with the following exception. The RLV11/RLV12 subsystems have an internal maintenance feature that is not tested by the RL11 diagnostics. Therefore, there is one additional diagnostic program. This program is called the CVRLA Diskless Test for use on the RLV11 subsystems. RLV12 subsystems use CVRLB Diskless Test. At some point in time CVRLB will replace CVRLA.

The diagnostic kit includes the same items as the RL11 diagnostic kit plus the CVRLAA0 test. The RLV11 kit designations are shown in Table B-9.

The DECX11 module is the same one used for the RL11.

**Table B-9 RLV11/RLV12 Diagnostic Kit Designations**

Designation	Contents
ZJ285-RB	Documentation and paper tape
ZJ285-RZ	Documentation only
ZJ285-PB	Paper tape only
ZJ285-FR	Microfiche only

### B.9.3 RL8A-Based Diagnostics

There are six free-standing diagnostic programs for the RL8A/RL01 Controller-based system. There is also a DECX8 module for use with the DECX8 system exerciser. These diagnostics are available as individual components (see Table B-10) or in a kit (see Table B-11).

**Table B-10 RL8/RL01 Diagnostic Components**

Part Number	Designation
AC-C656A-MA	AJRLAA0, RL8A Diskless Control Test (Document)
AH-C657A-MA	AJRLAA0, RL8A Diskless Control Test (Fiche)
AK-C658A-MA	AJRLAA0, RL8A Diskless Control Test (Paper tape)
AL-C659A-NA	AJRLAA0, RL8A Diskless Control Test (DECtape)
AC-C660A-MA	AJRLBA0, RL8A/RL01 Drive Test 1 (Document)
AH-C661A-MA	AJRLBA0, RL8A/RL01 Drive Test 1 (Fiche)
AK-C662A-MA	AJRLBA0, RL8A/RL01 Drive Test 1 (Paper tape)
AL-C663A-NA	AJRLBA0, RL8A/RL01 Drive Test 1 (DECtape)
AC-C664A-MA	AJRLCA0, RL8A/RL01 Drive Test 2 (Document)
AH-C665A-MA	AJRLCA0, RL8A/RL01 Drive Test 2 (Fiche)
AK-C666A-MA	AJRLCA0, RL8A/RL01 Drive Test 2 (Paper tape)
AL-C667A-NA	AJRLCA0, RL8A/RL01 Drive Test 2 (DECtape)
AC-C668A-MA	AJRLDA0, RL8A/RL01 Compat. Verify (Document)
AH-C669A-MA	AJRLDA0, RL8A/RL01 Compat. Verify (Fiche)
AK-C670A-MA	AJRLDA0, RL8A/RL01 Compat. Verify (Paper tape)
AL-C671A-NA	AJRLDA0, RL8A/RL01 Compat. Verify (DECtape)
AC-C672A-MA	AJRLEA0, RL8A/RL01 Perf. Exer. (Document)
AH-C673A-MA	AJRLEA0, RL8A/RL01 Perf. Exer. (Fiche)
AK-C674A-MA	AJRLEA0, RL8A/RL01 Perf. Exer. (Paper tape)
AL-C675A-NA	AJRLEA0, RL8A/RL01 Perf. Exer. (DECtape)
AC-C676A-MA	AXRLAA0, RL8A DECX8 Module (Document)
AH-C677A-MA	AXRLAA0, RL8A DECX8 Module (Fiche)
AK-C678A-MA	AXRLAA0, RL8A DECX8 Module (Paper tape)
AC-C682A-MA	AJRLGA0, RL8A/RL01 Pack Verify (Document)
AH-C683A-MA	AJRLGA0, RL8A/RL01 Pack Verify (Fiche)
AK-C684A-MA	AJRLGA0, RL8A/RL01 Pack Verify (Paper tape)
AL-C685A-NA	AJRLGA0, RL8A/RL01 Pack Verify (DECtape)



**Table B-11 RL8/RL01 Diagnostic Kits**

---

<b>Part Number</b>	<b>Contents</b>
ZB233-RB	Documentation and paper tape
ZB233-RZ	Documentation only
ZB233-PB	Paper tape only
ZB233-FR	Microfiche only

---

There are six free-standing diagnostic programs for the RL8/RL02 subsystem, plus a module for use with the DECX8 System Exerciser. They are available in kit form (Table B-12) or as individual components (Table B-13). The Diskless Controller Test (AJRLACO) is simply Revision C of the RL01 test and can test a subsystem with either RL01 or RL02 units. The other diagnostics test RL02-based systems only.

**Table B-12 RL8A Diagnostic Kits**

---

<b>Part Number</b>	<b>Contents</b>
ZF241-RB	Documentation and paper tape
ZF241-RZ	Documentation only
ZF241-PB	Paper tape only
ZF241-FR	Microfiche
ZF241-PH	RL02
ZF241-RH	RL02 and documentation

---

#### **B.10 USE OF THE M9312 BOOTSTRAP WITH AN RL11 SUBSYSTEM**

The M9312 module is used on many PDP-11 UNIBUS systems to provide bootstrap capability as well as other functions. The module has five IC sockets for ROM chips, four of which are reserved for peripheral bootstrap programs. There are several ROM chips available for the different peripheral devices, and an M9312 is configured by selecting the appropriate chips for the particular system on which it is used.

The RL subsystem bootstrap program is contained in ROM chip number 23-751A9. This chip can be ordered individually and is also available in kit MR11-EA, which consists of an M9312 module plus all the available ROM chips.

An RL system disk can be booted by a command to the console emulator (a program that is a feature of the M9312). The device mnemonic for the RL11 is DL or DLn, where n is the unit number (0 through 3).

**Table B-13 RL8/RL02 Diagnostic Components**

<b>Part Number</b>	<b>Name</b>	<b>Item</b>
AC-C656C-MA AH-C657C-MA AK-C658C-MA AL-C659C-NA	AJRLAC0 RL8A Diskless Control Test	Documentation Fiche Paper tape DECtape
AK-F362A-MA AH-F363A-MA AH-F364A-MA AL-F365A-MA AF-F362A-M0	AJRLHA0 RL8/RL02 Seek/Function	Documentation Paper tape Fiche DECtape DECO/DEPO
AC-F366A-MA AK-F367A-MA AH-F368A-MA AL-F369A-MA AF-F366A-M0	AJRIA0 RL8/RL02 Read/Write	Documentation Paper tape Fiche DECtape DECO/DEPO
AC-F370A-MA AK-F371A-MA AH-F372A-MA AL-F373A-MA AF-F370A-M0	AJRLJAO RL8/RL02 Drive Compat.	Documentation Paper tape Fiche DECtape DECO/DEPO
AC-F374A-MA AK-F375A-MA AH-F376A-MA AL-F377A-MA AF-F374A-M0	AJRLKA0 RL8/RL02 Perf. Exer.	Documentation Paper tape Fiche DECtape DEPO/DECO
AC-F378A-MA AK-F379A-MA AH-F380A-MA AL-F381A-MA AF-F378A-M0	AJRLLA0 RL8/RL02 Pack Verify	Documentation Paper tape Fiche DECtape DECO/DEPO
AC-F382A-MA AK-F383A-MA AH-F384A-MA AF-F38SA-M0	AXRLBA0 DEC/X8 MOD RL8/RL02	Documentation Paper tape Fiche DECO/DEPO

## APPENDIX C TOGGLE-IN PROGRAMS

### C.1 HEAD SELECTION PROGRAM FOR RL11/RLV11/RLV12

The following program causes head 1 (lower head) to be selected (on unit 0) if the WRITE PROTECT switch is in and head 0 (upper head) to be selected if the switch is out.

1000	012700	Housekeeping
1002	174400	
1004	012701	
1006	174404	
1010	105710	Wait
1012	100376	
1014	012711	Get Status Command
1016	000013	
1020	012710	
1022	000004	
1024	105710	Wait
1026	100376	
1030	013702	Status Word
1032	174406	
1034	006302	
1036	010203	
1040	006303	
1042	105702	Check HS Bit
1044	100405	
1046	005703	Check WL Bit
1050	100357	Equal, Loop
1052	012711	Set HS Bit
1054	000021	
1056	000404	Go to Seek Command
1060	005703	Check WL Bit
1062	100752	Equal, Loop
1064	012711	Reset HS Bit
1066	000001	
1070	012710	Seek Command
1072	000006	
1074	000745	Loop

## C.2 HEAD SELECTION PROGRAM FOR RL8A

The following program causes head 1 (lower head) to be selected (on unit 0) if the WRITE PROTECT switch is in and head 0 (upper head) to be selected if the switch is out.

200	6600	Clear Controller
201	1234	
202	6604	Get Status Command
203	6601	Wait
204	5203	
205	6615	First Word of Status
206	0232	
207	7640	Check HS Bit
210	5217	HS=1, Go to 217
211	6615	Second Word of Status
212	0233	
213	7650	Check WL Bit
214	5201	HS=WL, Go to 201
215	7332	
216	5224	
217	6615	Second Word of Status
220	0233	
221	7640	Check WL
222	5201	HS=WL, Go to 201
223	7300	
224	6603	HS to Command REG A
225	7325	
226	6604	Seek Command to Command REG B
227	6601	Wait
230	5227	
231	5201	Loop to 201
232	0100	Constant
233	0040	Constant
234	1002	

### C.3 GET STATUS (WITH OR WITHOUT RESET) ON AN RL11/RLV11/RLV12 SUBSYSTEM

To accomplish this, it is necessary to:

1. Deposit a 3 into DAR at 774404 (or 13 to Reset)
2. Deposit a 4 into CSR at 774400 (or 404, 1004, 1404 for units 1, 2, 3)
3. Wait for operation to be complete
4. Examine contents of MPR at 774406.

On some PDP-11 systems this can be accomplished manually using the console. On other PDP-11 systems it is necessary to run a program such as given below. Start at 1000 and when it halts, examine memory location 1032.

To get status on unit 1, 2, or 3 modify location 1010 to 404, 1004, or 1404.

To reset drive modify location 1002 to 13.

1000	012737	Get Status Command
1002	000003	Use 13 to Reset
1004	174404	
1006	012737	
1010	000004	Use 404, 1004, 1404 for Units 1, 2, 3
1012	174400	
1014	105737	Wait
1016	174400	
1020	100375	
1022	013737	Move Result to Memory
1024	174406	
1026	001032	
1030	000000	Halt
1032	000000	Result

#### C.4 GET STATUS ON AN RL&A SUBSYSTEM

The following program will get status from unit 0. To access unit 1, 2, 3 change location 212 to 1102, 1202, 1302.

Start the program at 200. At the first halt, the first byte of the status word is displayed in the accumulator. At the second halt, the second byte is displayed.

200	7300	
201	1212	Get Status
202	6604	
203	6601	Wait
204	5203	
205	6615	Get First Byte
206	7402	Halt and Display First Byte
207	6615	Get Second Byte
210	7402	Halt and Display Second Byte
211	5200	Jump to Start
212	1002	Constant

### C.5 OSCILLATING SEEK FOR RL11/RLV11/RLV12

The following program will cause unit zero to perform an oscillating seek. To drive units other than unit 0, swap the unit number plugs or modify locations 1044 and 1054 to reflect the unit number in bits 8 and 9.

The number of cylinders involved is inserted into bits 15 through 7 and bit 0 is set in the switch register before starting the programs at 1000. If no switch register is available, modify location 1012 from 177570 to 001060 and put the number of cylinders in bits 17 through 7 and set bit 0 in location 1060.

The common values for the switch register are:

Number of cylinders (in decimal)		Value of Switch Register (in octal)
1		000205
85		025205
170		052405
255		077605
511		177605
1000	012706	Set Stack Pointer
1002	001000	
1004	012700	Set Device Address into R0
1006	174400	
1010	013701	Set Difference into R1
1012	177570	
1014	004537	Go Seek
1016	001032	
1020	042701	Change direction bit in R1
1022	000004	
1024	004537	Go Seek
1026	001032	
1030	000767	Loop Back
1032	105710	Wait
1034	100376	
1036	010137	Seek
1040	174404	
1042	012710	
1044	000006	
1046	105710	Wait
1050	100376	
1052	012710	Read Header to kill time for SKTO
1054	000010	
1056	000205	Return

## C.6 OSCILLATING SEEK FOR RL8A

The following program will cause unit 0 to perform an oscillating seek. To drive units other than 0, swap unit number plugs. Insert the number of cylinders into the switches before starting at location 200. The usual values for the switch register are: 1 cyl=1, 85 cyl=125, 170 cyl=252, 255 cyl=377 and 511 cyl=777.

200	7201	Reset
201	6604	
202	7604	Get Number
203	4221	Go Wait for Ready
204	3225	Store number
205	1225	
206	6603	Seek
207	7325	
210	6604	
211	4221	Go Wait for Ready
212	7307	Read Header to Delay for SKTO
213	6604	
214	1225	
215	1226	Change Direction Bit
216	7500	Check for Time to Restore
217	5202	Loop to Start
220	5203	Loop
221	0000	Wait for Ready
222	6601	
223	5222	
224	5621	
225	0000	Temp
226	4000	Constant



## APPENDIX D

### RL11 CONFIGURATION AND INSTALLATION CONSIDERATIONS

#### D.1 SPC CONSIDERATIONS

The RL11 is a small peripheral controller (SPC) but does not unconditionally fit into any SPC slot. Early SPCs were always quad-height modules or combinations of smaller (single or dual) modules that involved only four rows. Thus, the standard pin assignments applied only to rows C, D, E and F on a hex-height backplane. Many new options, such as the RL11, are hex-height modules and therefore require that rows A and B be vacant since some SPC slots use rows A and B for UNIBUS cables or power connectors. Some hex-height options require standard UNIBUS pinning on rows A and B and some require Modified UNIBUS Device (MUD) pinning. In the case of the RL11, the only connections used on rows A and B are the +5v and ground. Thus, these rows can be either standard UNIBUS or MUD pinning.

The early SPCs did not utilize direct memory access (DMA) data transfers to/from memory and therefore those signals were not part of the original SPC pin assignments. Some of the newer options, such as the RL11, do utilize DMA transfers. There is a new pin assignment called SPC PRIME that includes these signals. If the RL11 is to be used in an older (non-SPC PRIME) slot then it is necessary to ensure that the following signals are wired on the backplane.

- Pin CA1 – NPG In
- Pin CB1 – NPG Out
- Pin FJ1 – NPR
- Pin CV1 – AC LO
- Pin CU1 – +15v

If the slot has SPC PRIME pinning then another precaution must be taken. NPG continuity is maintained across an empty SPC PRIME slot by a backplane jumper from pin CA1 to pin CB1. This jumper must be removed whenever a DMA-type option (such as an RL11) is installed, and the jumper must be added if the module is removed. This consideration is in addition to the normal bus grant continuity card used in row D of all empty SPC slots.

## D.2 CONFIGURATION CONSIDERATIONS

When configuring a UNIBUS system for the best priority assignments, two characteristics of a peripheral option must be taken into consideration. These are the peak word transfer rate and the T1 time (T1 time is a function of the peak transfer rate and the silo size). The RL11 has a peak transfer rate of 256 kHz (3.9 microseconds/word) and a T1 time of 62.4 microseconds. These values dictate its position in the priority scheme. The recommended priority scheme is listed below.

### CPU

#### Memory

RK11/RK05

TM11/TU10

TC11/TU56

RL11/RL01-RL02

RJS04

RM02

RJP04

RK611/RK06-RK07

RP11C/RP03

RJS03

TJU16

RF11/RS11

### DB11

Other general configuration rules are listed below.

- On a PDP-11 UNIBUS, a combination of two disk subsystems and a tape or floppy disk subsystem is considered maximum.
- On a PDP-11/70 system, one UNIBUS disk subsystem is considered maximum if there are MASSBUS disks.
- A disk subsystem should not be installed beyond a bus expander.

RL01/RL02  
TECHNICAL MANUAL  
EK-RL122-TM-001

### Reader's Comments

Your comments and suggestions will help us in our continuous effort to improve the quality and usefulness of our publications.

What is your general reaction to this manual? In your judgment is it complete, accurate, well organized, well written, etc.? Is it easy to use? \_\_\_\_\_  
\_\_\_\_\_  
\_\_\_\_\_

What features are most useful? \_\_\_\_\_  
\_\_\_\_\_  
\_\_\_\_\_

What faults or errors have you found in the manual? \_\_\_\_\_  
\_\_\_\_\_  
\_\_\_\_\_

Does this manual satisfy the need you think it was intended to satisfy? \_\_\_\_\_

Does it satisfy *your* needs? \_\_\_\_\_ Why? \_\_\_\_\_  
\_\_\_\_\_  
\_\_\_\_\_

Please send me the current copy of the *Technical Documentation Catalog*, which contains information on the remainder of DIGITAL's technical documentation.

Name \_\_\_\_\_ Street \_\_\_\_\_  
Title \_\_\_\_\_ City \_\_\_\_\_  
Company \_\_\_\_\_ State/Country \_\_\_\_\_  
Department \_\_\_\_\_ Zip \_\_\_\_\_

Additional copies of this document are available from:

Digital Equipment Corporation  
444 Whitney Street  
Northboro, Ma 01532  
Attention: Communications Services (NR2/M15)  
Customer Services Section

Order No.     EK-RL122-TM-001

-----  
**Fold Here**  
-----

-----  
**Do Not Tear - Fold Here and Staple**  
-----

**digital**



**No Postage  
Necessary  
if Mailed in the  
United States**

**BUSINESS REPLY MAIL**  
FIRST CLASS      PERMIT NO.33      MAYNARD, MA.  
POSTAGE WILL BE PAID BY ADDRESSEE

**Digital Equipment Corporation  
301 Rockrimmon Boulevard South  
Colorado Springs, Colorado 80963**

**Educational Services  
Development and Publishing**



