

Replacement DELNI

Technical Information

Order Number: EK-DELNX-TM.A01

Revision Update Information: This is a new manual.

February 1992

© Digital Equipment Corporation 1992. All rights reserved. Printed in U.S.A.

The reproduction of this material, in part or whole, is strictly prohibited. For copy information, contact the Digital Education and Training Department, Digital Equipment Corporation, Maynard, Massachusetts 01754.

The information in this document is subject to change without notice and should not be construed as a commitment by Digital Equipment Corporation. Digital Equipment Corporation assumes no responsibility for any errors that may appear in this document.

Restricted Rights: Use, duplication, or disclosure by the U.S. Government is subject to restrictions as set forth in subparagraph (c)(1)(ii) of the Rights in Technical Data and Computer Software clause at DFARS 252.227-7013.

FCC NOTICE: This equipment generates and uses radio frequency energy and if not installed and used properly, that is, in strict accordance with the manufacturer's instructions, may cause interference to radio and television reception. It has been type tested and found to comply with the limits for a Class B computing device in accordance with specifications in Subpart J of Part 15 of FCC rules, which are designed to provide reasonable protection against such interference in a residential installation. However, there is no guarantee that interference will not occur in a particular installation. If this equipment does cause interference to radio or television, which can be determined by turning the equipment off and on, the user is encouraged to try to correct the interference by one or more of the following measures:

- reorient the receiving antenna
- relocate the computer with respect to the receiver
- move the computer away from the receiver
- plug the computer into a different outlet so that computer and receiver are on different branch circuits.

If necessary, the user should consult the dealer or an experienced radio/television technician for additional suggestions. The user may find the following booklet prepared by the Federal Communications Commission helpful:

"How to Identify and Resolve Radio-TV Interference Problems."

This booklet is available from the US Government Printing Office, Washington, DC 20402, Stock No. 004-000-00345-4.

The postpaid READER'S COMMENTS form in this document requests the user's critical evaluation to assist in preparing future documentation.

The following are trademarks of Digital Equipment Corporation:
DECNA, DELNI, DELUA, DEQNA, DEUNA, VAX DOCUMENT, and the DIGITAL logo.

This document was prepared using VAX DOCUMENT, Version 2.0.

Contents

Preface	v
1 Introduction	
1.1 Overview	1-1
1.1.1 Communication Interfaces	1-2
1.1.2 Operating Modes/Operational Communication Interfaces	1-2
1.1.3 Operational Applications	1-2
1.2 DELNI Functional Description	1-3
1.2.1 LOCAL Mode Operation	1-3
1.2.2 GLOBAL Mode Operation	1-3
1.3 DELNI Physical Description	1-4
1.3.1 Physical Characteristics	1-4
1.3.2 Configurations	1-4
1.4 DELNI Controls, Indicators, and Circuit Breaker	1-6
1.4.1 Controls and Indicators	1-7
1.4.2 Circuit Breaker	1-7
1.5 DELNI Rackmount	1-8
1.6 Related Documentation	1-8
2 DELNI Network Configuration Guidelines	
2.1 Configuration Guidelines	2-1
2.1.1 Standalone DELNI LAN	2-1
2.1.2 Two-Tier DELNI LAN	2-1
2.1.3 Connected DELNI LAN	2-1
2.2 Configuration Limitations	2-2
2.3 Transceiver Cable Types	2-2
3 DELNI Interfaces, Input/Output Signal Flow, and Specifications	
3.1 Communication Interfaces	3-1
3.1.1 Local Connector Interfaces	3-1
3.1.2 Global Connector Interfaces	3-3
3.2 Input/Output Signal Flow and Timing Relationships	3-4
3.2.1 LOCAL Mode Signal Flow and Timing Relationships	3-4
3.2.2 GLOBAL Mode Signal Flow and Timing Relationships	3-6
3.3 Input/Output Circuit and Signal Characteristics	3-10
3.3.1 CHn TRANSMIT Pair Circuit Characteristics	3-10
3.3.2 CHn TRANSMIT Pair Signal Characteristics	3-10
3.3.3 CHn RECEIVE Pair Circuit Characteristics	3-11
3.3.4 CHn RECEIVE Pair Signal Characteristics	3-11
3.3.5 CHn COLLISION PRESENCE Pair Circuit Characteristics	3-12
3.3.6 CHn COLLISION PRESENCE Pair Signal Characteristics	3-12

3.3.7	XCVR TRANSMIT Pair Circuit Characteristics	3-13
3.3.8	XCVR TRANSMIT Pair Signal Characteristics	3-13
3.3.9	XCVR RECEIVE Pair Circuit Characteristics	3-14
3.3.10	XCVR RECEIVE Pair Signal Characteristics	3-14
3.3.11	XCVR COLLISION PRESENCE Pair Circuit Characteristics	3-15
3.3.12	XCVR COLLISION PRESENCE Pair Signal Characteristics	3-16
3.3.13	XCVR POWER Pair Characteristics	3-16
3.3.14	XCVR POWER Pair External Load Requirements	3-17
3.4	Input Power Requirements	3-18
3.5	Environmental Requirements	3-19

4 Theory of Operation

4.1	DELNI Circuit Characteristics	4-1
4.1.1	Power Supply	4-1
4.1.2	Operating Mode Control	4-2
4.1.3	AUI Concentrator Chip (ACC)	4-2
4.1.4	Local Interfaces	4-2
4.1.5	Global Interface	4-2
4.2	DELNI Functional Operation	4-4
4.2.1	LOCAL Mode Functional Theory	4-4
4.2.2	GLOBAL Mode Functional Theory	4-4

Figures

1-1	Digital Ethernet Local Network Interconnect (DELNI)	1-1
1-2	DELNI Controls and Indicators	1-6
2-1	Configuration Guidelines and Limitations: Standalone DELNI LAN	2-3
2-2	Configuration Guidelines and Limitations: Two-Tier DELNI LAN	2-4
2-3	Configuration Guidelines and Limitations: Connected DELNI LAN	2-5
3-1	LOCAL Mode Signal Flow Diagram	3-5
3-2	LOCAL Mode Signal Timing Diagram	3-6
3-3	GLOBAL Mode Signal Flow Diagram	3-8
3-4	GLOBAL Mode Signal Timing Diagram	3-9
4-1	DELNI Functional Block Diagram	4-3

Tables

1-1	DELNI Country Kits	1-5
1-2	Controls and Indicators	1-7
1-3	Related Documentation	1-8
3-1	Local Connector Signal Line Interfaces	3-2
3-2	Global Connector Signal Line Interfaces	3-3

Preface

OVERVIEW

The *replacement* Digital Ethernet Local Network Interconnect (DELNI) unit is designed to provide the same functionality as the *original* DELNI unit. The replacement DELNI utilizes the newest technology available to increase reliability while maintaining high-quality standards. The metal box and removable plastic dress skins of the original DELNI have been eliminated with the design of a new plastic box for the replacement DELNI. This has eliminated the need to remove the plastic dress skins for a rackmount configuration.

This manual describes the physical, electrical, and functional characteristics of the replacement DELNI. This document is intended to provide the Digital Services Engineer with a working knowledge of the replacement DELNI unit.

IMPORTANT

The information in this manual deals with the replacement DELNI only. For ease of presentation, the replacement DELNI will be referred to as the DELNI.

This manual consists of the following:

- **Chapter 1** provides an overview and a functional/physical description of the replacement DELNI unit.
- **Chapter 2** provides network configuration guidelines for the replacement DELNI unit.
- **Chapter 3** provides information on DELNI interfaces, input/output signal flow, and specifications for the replacement DELNI unit.
- **Chapter 4** provides information on the theory of operation for the replacement DELNI unit.

1.1 Overview

The DELNI unit (see Figure 1-1) is a hardware communications device. The DELNI unit and associated cables can be used to create several types of Local Area Networks (LANs) through which Ethernet Compatible Stations (Stations) may communicate using the Digital Ethernet Carrier Sense Multiple Access /Collision Detect (CSMA/CD) protocol.

Figure 1-1 Digital Ethernet Local Network Interconnect (DELNI)

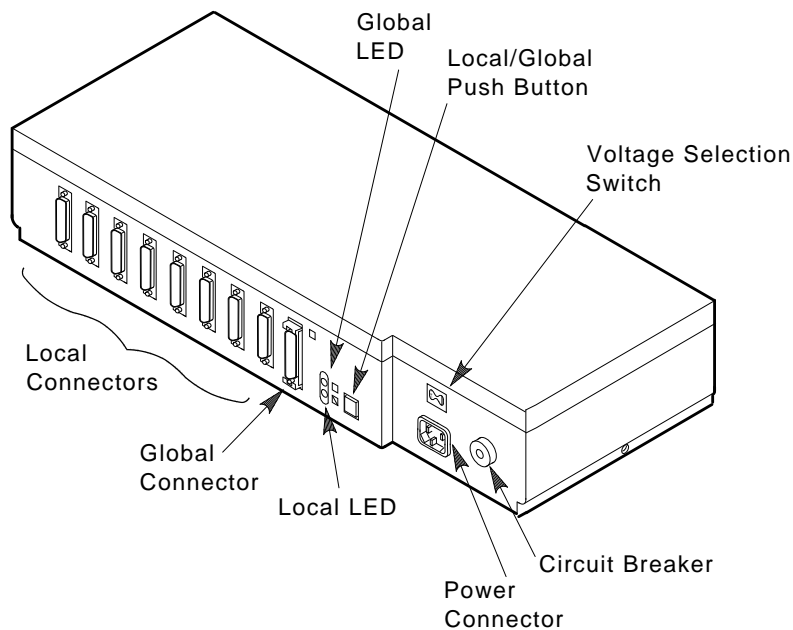

MKV-04000202-01-DGS

Introduction

1.1.1 Communication Interfaces

The DELNI unit provides nine communication interfaces. They consist of:

- Eight (8) local connectors (labeled 1 through 8 on the front panel)
- One (1) global connector (labeled □ on the front panel)

Each of the eight local connectors have the following paired signal line interfaces.

- TRANSMIT
- RECEIVE
- COLLISION PRESENCE

The global connector has the following paired signal line interfaces.

- TRANSMIT
- RECEIVE
- COLLISION PRESENCE
- POWER (+12 Vdc and +12 Vdc return)

1.1.2 Operating Modes/Operational Communication Interfaces

The DELNI unit has two selectable modes of operation: LOCAL and GLOBAL.

In the LOCAL mode of operation, all communication interfaces with the DELNI unit are by way of the local connectors.

In the GLOBAL mode of operation, the communication interfaces with the DELNI unit are through both the local and global connectors.

1.1.3 Operational Applications

The DELNI unit and associated cables may be used to create the following types of Local Area Networks (LANs):

- Standalone DELNI LAN—Network through which up to 8 stations can communicate.
- Two-Tier DELNI LAN—Network through which up to 64 stations can communicate.
- Connected DELNI LAN—Network through which up to 8 stations can communicate on a larger Ethernet network through a single Ethernet transceiver interface.

NOTE

Refer to the *Ethernet Installation Guide* (EK-ETHER-IN) for detailed configuration requirements. General configuration requirements are provided in Chapter 2 of this document.

1.2 DELNI Functional Description

The functional operation of the DELNI unit is dependent on the mode of operation selected: LOCAL or GLOBAL.

1.2.1 LOCAL Mode Operation

In the LOCAL mode, the DELNI unit performs the following functions:

- Transmit/Receive—Provides the data paths between the TRANSMIT and RECEIVE pairs of the local connectors.
- Heartbeat Signaling—Provides signaling on the COLLISION PRESENCE pairs of the local connectors after the end of each transmission interval.
- Collision Detection—Detects the condition in which two or more stations are attempting to transmit simultaneously.
- Collision Signaling—Provides signaling on the COLLISION PRESENCE pairs of the local connectors when a collision is detected.

1.2.2 GLOBAL Mode Operation

In the GLOBAL mode, the DELNI unit performs the following functions:

- Transmit—Provides a data path from the TRANSMIT pairs of the local connectors to the TRANSMIT pair of the global connector. It is through this data path that stations connected to the local connectors can send data to a global network device for transmission on a larger Ethernet network.
- Local Collision Detection—Detects the condition in which two or more stations connected to the local connectors are attempting to transmit simultaneously.
- Local Collision Condition Data Control and Collision Signaling—During a local collision condition, controls the data sent to the global network device. This ensures that the duty cycle and minimum packet length requirements are not violated. Also, provides signaling on the COLLISION PRESENCE pairs of the local connectors.
- Receive—Provides a data path from the RECEIVE pair of the global connector to the RECEIVE pairs of the local connectors. This data path distributes the data received from a global network device to the stations connected to the local connectors.
- Global Collision and Heartbeat Signal Detection—Detects the presence of signals asserted on the COLLISION PRESENCE pair of the global connector.
- Global Collision and Heartbeat Signaling—Provides signaling on the COLLISION PRESENCE pairs of the local connectors whenever a signal is detected on the COLLISION PRESENCE pair of the global connector.

Introduction

1.3 DELNI Physical Description

The following sections outline the physical characteristics and configurations of the DELNI unit.

1.3.1 Physical Characteristics

The dimensions and weight of the DELNI unit are as follows:

- Width 44.50 cm (17.52 in)
- Depth 17.80 cm (7.01 in)
- Height 8.26 cm (3.25 in) (including feet)
- Weight 2.60 kg (5.73 lb)

1.3.2 Configurations

There are two configurations of the DELNI unit: DELNI-BA configuration for U.S. applications and DELNI-BB configuration for European/GIA applications. The differences between the two configurations are:

- DELNI-BA (U.S.)
 - The 120/240 switch is preset to the 120 position
 - *Replacement DELNI Installation and Operating Information* manual
 - AC power cord
- DELNI-BB (European/GIA)
 - The 120/240 switch is preset to the 240 position

NOTE

No ac power cord or *Replacement DELNI Installation and Operating Information* manual is shipped with the DELNI-BB configuration. A country kit (containing a power cord and *Replacement DELNI Installation and Operating Information* manual) must be ordered separately. Table 1–1 lists the country kits available.

Table 1–1 DELNI Country Kits

Order Designation	Primary Country
DELNK-AB	Belgium
DELNK-AC	Canada—France
DELNK-AD	Denmark
DELNK-AE	United Kingdom
DELNK-AF	Finland
DELNK-AG	Germany
DELNK-AH	Holland
DELNK-AI	Italy
DELNK-AK	Switzerland—France
DELNK-AL	Switzerland—Germany
DELNK-AM	Sweden
DELNK-AN	Norway
DELNK-AP	France
DELNK-AQ	Canada—England
DELNK-AS	Spain
DELNK-AZ	Australia

Introduction

1.4 DELNI Controls, Indicators, and Circuit Breaker

The location of the controls, indicators, and circuit breaker for the DELNI unit are shown in Figure 1-2.

Figure 1-2 DELNI Controls and Indicators

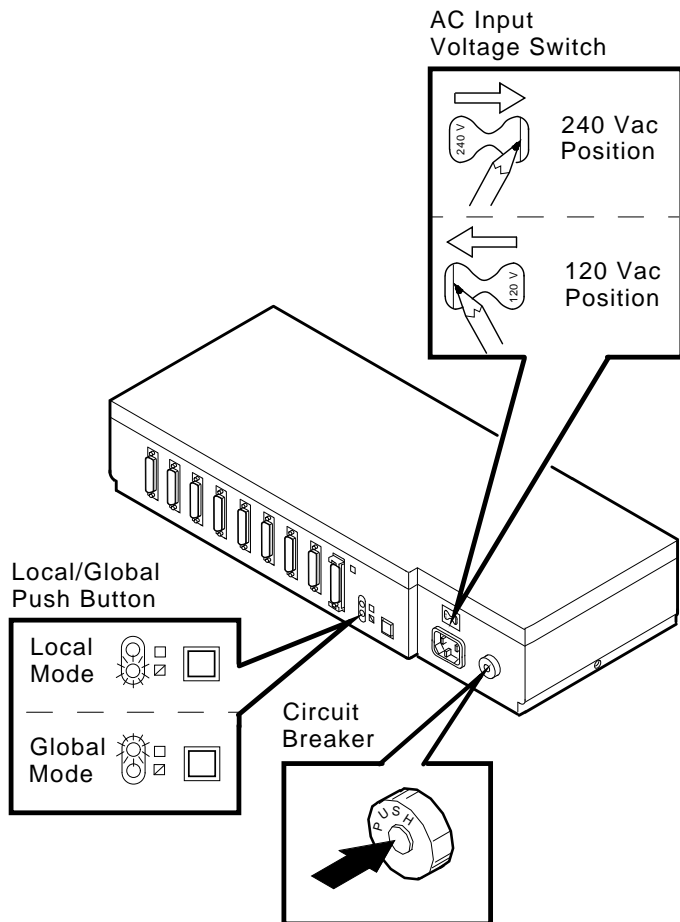

MKV-04000202-35-DGS

1.4.1 Controls and Indicators

Table 1–2 describes each of the controls and indicators and specifies their function.

Table 1–2 Controls and Indicators

Control/Indicator (Type)	Function
<input type="checkbox"/> / <input type="checkbox"/> LEDs with push-button control	DELNI Operating Mode Selector
<input type="checkbox"/> LED lit	Selects GLOBAL mode of operation.
<input type="checkbox"/> LED lit	Selects LOCAL mode of operation.
<input type="checkbox"/> / <input type="checkbox"/> LEDs	Power Supply Indicator Either of the Local or Global LEDs being lit indicates that the +5 Vdc internal Vcc power supply is functioning. These LEDs do not reflect the state of the +12 Vdc power supply used for the global port transceiver power.
120/240 (Two-position slide switch)	AC Input Voltage Switch
120	Makes DELNI unit compatible with 90 to 128 Vac input power source.
240	Makes DELNI unit compatible with 180 to 256 Vac input power source.

1.4.2 Circuit Breaker

Both the DELNI-BA and the DELNI-BB are equipped with a 2 A thermal circuit breaker that contains a reset button.

Introduction

1.5 DELNI Rackmount

The DELNI unit may be mounted in a standard 19-inch (48.26-centimeter) rack using the rackmount brackets and hardware that are shipped with the unit.

1.6 Related Documentation

Other documents relative to the DELNI unit and associated Ethernet networks are listed in Table 1–3.

Table 1–3 Related Documentation

Title	Order Number	Description
<i>DELNI Field Maintenance Print Set</i>	MP-01656	Contains unit assembly drawings, parts listing, and schematic diagrams.
<i>Replacement DELNI Installation and Operating Information</i>	EK-DELNX-IN	Outlines Ethernet networking configurations that can be developed using the DELNI unit. Also provides tabletop and rackmount installation instructions, troubleshooting information, and a description of service options.
<i>Introduction to Local Area Networks</i>	EB-22714-18	Describes the terms, concepts, designs, and strategies related to local area networks.
<i>The Ethernet, A Local Area Network, Data Link Layer and Physical Layer Specification</i>	AA-K759A-TK	Describes the design constraints and functional requirements for components to be used in the Ethernet environment. Also discusses the protocol to be used for communication on the Ethernet.
<i>Ethernet Installation Guide</i>	EK-ETHER-IN	Two volumes with Volume 1 containing detailed site planning information and Volume 2 containing detailed installation instructions.

DELNI Network Configuration Guidelines

2.1 Configuration Guidelines

Basic configuration guidelines for the three DELNI LAN Ethernet environments (standalone DELNI LAN, two-tier DELNI LAN, and connected DELNI LAN) are outlined in the following sections and in Figure 2–1, Figure 2–2, and Figure 2–3. Restrictions regarding the length of cables that may be used are defined in Section 2.2.

2.1.1 Standalone DELNI LAN

In a standalone DELNI LAN application (see Figure 2–1), all stations are interconnected by way of a single DELNI unit. All station interfaces to the DELNI unit are through the local connectors and the DELNI unit is operated in the LOCAL mode.

2.1.2 Two-Tier DELNI LAN

In a two-tier DELNI LAN application (see Figure 2–2), there may be as many as nine DELNI units with one DELNI unit operating in the LOCAL mode and up to eight DELNI units operating in the GLOBAL mode. The interfaces between stations and DELNI units of a typical two-tier DELNI LAN are as follows:

- All station interfaces to the DELNI units are through the local connectors.
- The global connector of each DELNI unit operating in the GLOBAL mode is connected to the local connector of the DELNI unit operating in the LOCAL mode.

2.1.3 Connected DELNI LAN

In a connected DELNI LAN application (see Figure 2–3), the stations are connected to the local connectors of a single DELNI unit operating in the GLOBAL mode. The global connector of the DELNI unit is connected to an Ethernet transceiver.

DELNI Network Configuration Guidelines

2.2 Configuration Limitations

The primary configuration limitations are due to the maximum length of transceiver cable that can be used to interconnect the stations and DELNI units. The maximum length of transceiver cable that may be used is dependent on the following parameters:

- Type of transceiver cable used
- Type of Ethernet communications controller installed in the station
- DELNI LAN configuration

Figure 2–1, Figure 2–2, and Figure 2–3 outline the maximum cable lengths for the three DELNI LAN configurations. Each figure shows the restrictions associated with several types of Ethernet communications controllers and for two types of transceiver cables.

2.3 Transceiver Cable Types

Two types of transceiver cables are as follows:

- BNE3X-XX—Transceiver cable
- BNE4X-XX—Office transceiver cable

These cables have different electrical signal attenuation characteristics. The cable length restrictions called out in Figure 2–1, Figure 2–2, and Figure 2–3 assume that only one type of cable is used in each cabling run (that is, the attenuation characteristics are constant). If the two cable types are connected to create a cabling run, the maximum cable length allowable may be calculated using the following relationship.

The attenuation of a 2 meter length of BNE4X-XX cable is equivalent to the attenuation of an 8 meter length of BNE3X-XX cable.

DELNI Network Configuration Guidelines

Figure 2-1 Configuration Guidelines and Limitations: Standalone DELNI LAN

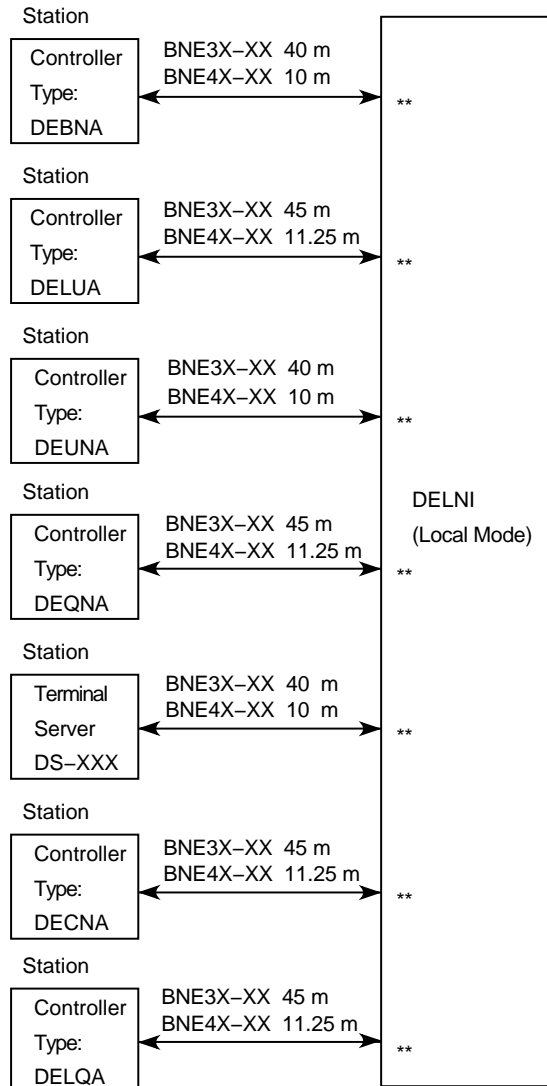

NOTE
 The Differences in Cable Lengths Specified for Use with Each Type Controller Are Due to the Lengths and Type of Cabling That is a Part of Each Controller.

Legend
 ** Local Connector
 ## Global Connector

MKV-04000202-28-RAGS

DELNI Network Configuration Guidelines

Figure 2-2 Configuration Guidelines and Limitations: Two-Tier DELNI LAN

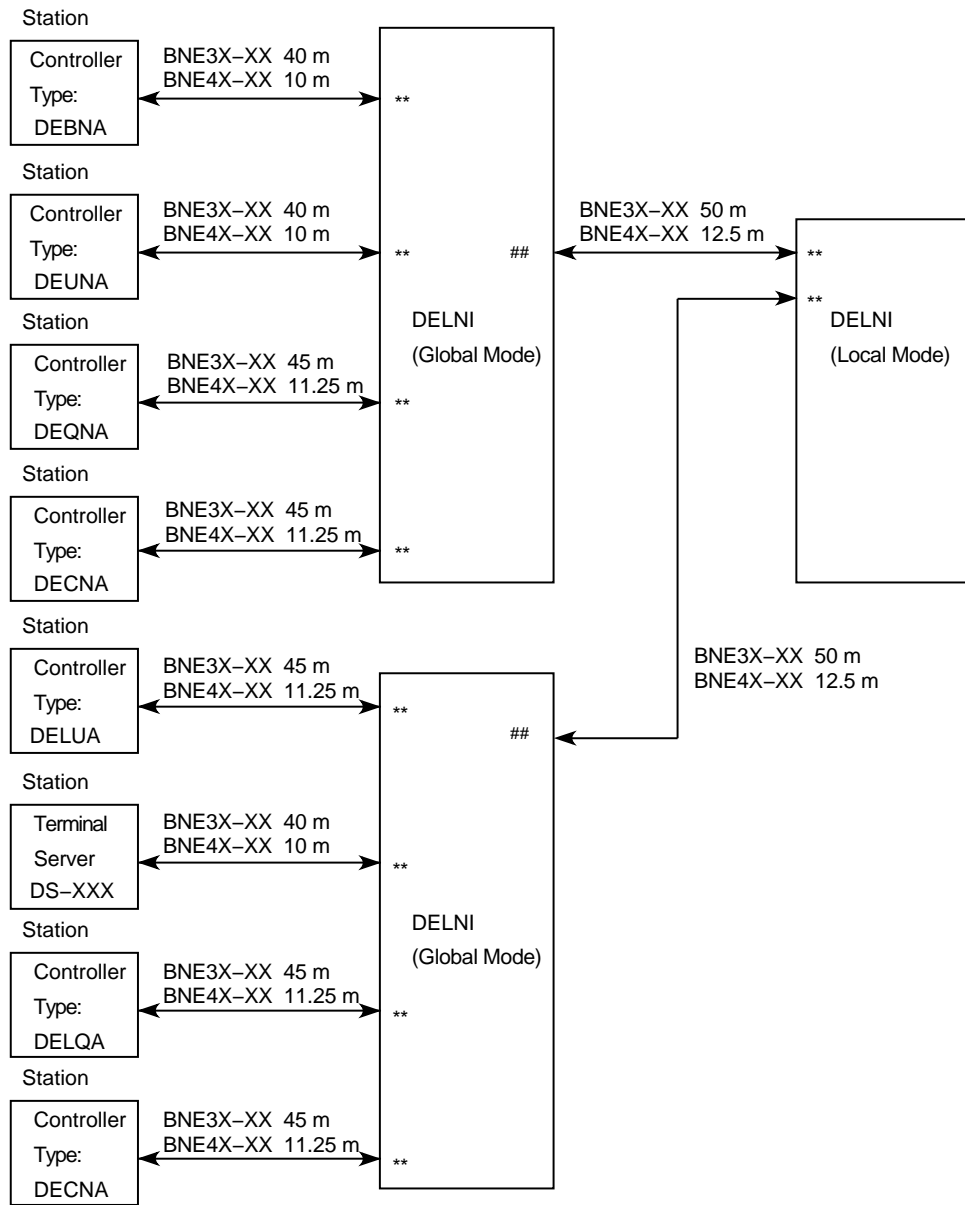

NOTE
 The Differences in Cable Lengths Specified for Use with Each Type Controller Are Due to the Lengths and Type of Cabling That is a Part of Each Controller.

Legend
 ** Local Connector
 ## Global Connector

MKV-040000202-29-RAGS

DELNI Network Configuration Guidelines

Figure 2-3 Configuration Guidelines and Limitations: Connected DELNI LAN

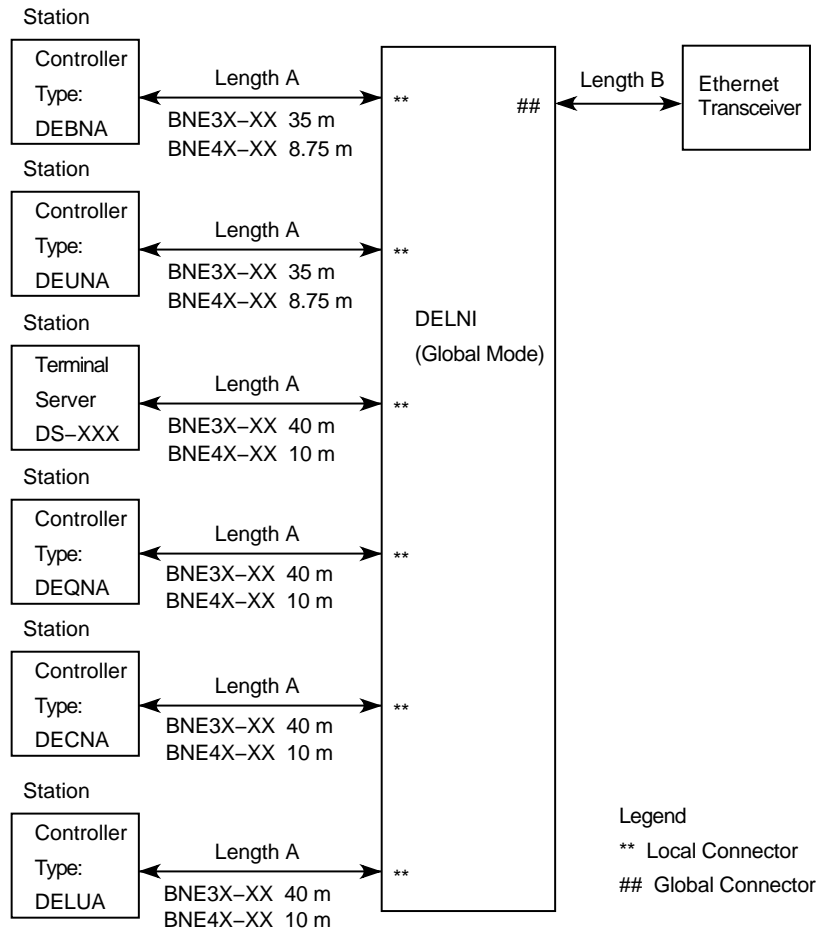

NOTE

The Lengths Specified Under "Length A" Are the Total Cable Lengths (Length A Plus Length B) Allowable Between the Controller and the Ethernet Transceiver.

The Differences in Cable Lengths Specified for Use with Each Type Controller Are Due to the Lengths and Type of Cabling That is a Part of Each Controller.

The Cable Segment Labeled "Length B" May Be Made Up of Transceiver Cables Joined in an Etherjack Connection Box.

MKV-04000202-30-RAGS

DELNI Interfaces, Input/Output Signal Flow, and Specifications

3.1 Communication Interfaces

The DELNI communication interfaces are accessed through the following connectors:

- Eight (8) local connectors
- One (1) global connector

3.1.1 Local Connector Interfaces

The eight local connectors are *physically* isolated from the DELNI safety earth /logic reference ground. The backshell of each of these connectors is *electrically* connected to the DELNI safety earth/logic reference ground through capacitors to maintain electrical isolation. The electrical isolation characteristics are:

- Impedance (connector backshell to safety earth/logic reference ground) 3 MHz to 30 MHz
 - 10 Ω maximum
 - 0.5 Ω minimum
- Isolation at 60 Hz
 - 280 k Ω typical
 - 250 k Ω minimum
- Breakdown voltage at 60 Hz
 - 270 V rms

Each of the eight local connectors provide the signal line interfaces listed in Table 3–1.

DELNI Interfaces, Input/Output Signal Flow, and Specifications

Table 3–1 Local Connector Signal Line Interfaces

Local Connector Pin	Interface Signal Designation
1	No Connection
2	CH _n COLLISION PRESENCE (+) ¹
3	CH _n TRANSMIT (+) ²
4	Reserved
5	CH _n RECEIVE (+) ¹
6	POWER (RTN) ³
7	Reserved
8	Reserved
9	CH _n COLLISION PRESENCE (–) ¹
10	CH _n TRANSMIT (–) ²
11	Reserved
12	CH _n RECEIVE (–) ¹
13	POWER (+) ³
14	Reserved
15	Reserved

¹Denotes output signals.

²Denotes input signals.

³POWER input not used at DELNI unit (no internal connection).

3.1.2 Global Connector Interfaces

The global connector is physically and electrically connected directly to the DELNI safety earth/logic reference ground by the metal shell of the connector. The electrical characteristics of this connection are:

- Resistive at dc 0.10 Ω maximum
- Inductive at 10 MHz 50 nH

The global connector provides the signal line interfaces listed in Table 3–2.

Table 3–2 Global Connector Signal Line Interfaces

Global Connector Pin	Interface Signal Designation
1	No Connection
2	XCVR COLLISION PRESENCE (+) ²
3	XCVR TRANSMIT (+) ¹
4	Reserved
5	XCVR RECEIVE (+) ²
6	XCVR POWER (RTN) ¹
7	Reserved
8	Reserved
9	XCVR COLLISION PRESENCE (–) ²
10	XCVR TRANSMIT (–) ¹
11	Reserved
12	XCVR RECEIVE (–) ²
13	XCVR POWER (+) ¹
14	Reserved
15	Reserved

¹Denotes output signals.

²Denotes input signals.

3.2 Input/Output Signal Flow and Timing Relationships

The following sections describe the signal flow and timing relationships when in LOCAL mode and in GLOBAL mode.

3.2.1 LOCAL Mode Signal Flow and Timing Relationships

In the LOCAL mode of operation, the signal asserted on a CHn TRANSMIT pair is routed to each of the CHn RECEIVE pairs (Figure 3–1).

Following termination of the signal asserted on the CHn TRANSMIT pair, a heartbeat signal is asserted on all CHn COLLISION PRESENCE pairs (Figure 3–2).

The time delay between the assertion of the CHn TRANSMIT pair signal and the assertion of the CHn RECEIVE pairs signal is due to the DELNI squelch circuit characteristics. The time delay between the data content of the CHn TRANSMIT pair signal and the data content of the CHn RECEIVE pair signals is due to steady-state propagation delay through the DELNI unit.

The CHn COLLISION PRESENCE pairs of the DELNI unit are asserted during the following two conditions:

1. After the end of each transmission interval (heartbeat signaling)
2. During a transmission interval in which two or more CHn TRANSMIT pairs are being asserted simultaneously (collision condition)

For heartbeat signaling, a short duration 10 MHz signal is asserted on all CHn COLLISION PRESENCE pairs shortly after the end of packet transmission.

For collision condition signaling, a 10 MHz signal is asserted on all CHn COLLISION PRESENCE pairs until the conflicting CHn TRANSMIT pairs are deasserted. Therefore, no time duration is specified in Figure 3–2 for the collision signaling condition. (The link level protocol specifies times of 320 ns minimum and 480 ns maximum.)

DELNI Interfaces, Input/Output Signal Flow, and Specifications

Figure 3-1 LOCAL Mode Signal Flow Diagram

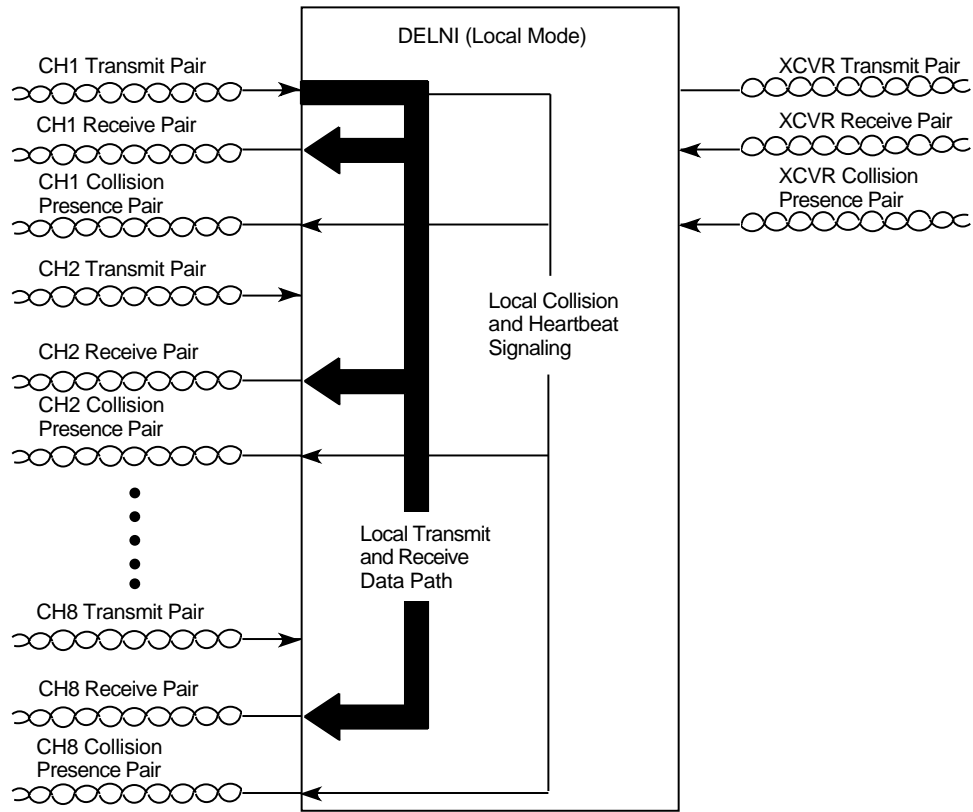

MKV-040000202-31-RAGS

DELNI Interfaces, Input/Output Signal Flow, and Specifications

Figure 3–2 LOCAL Mode Signal Timing Diagram

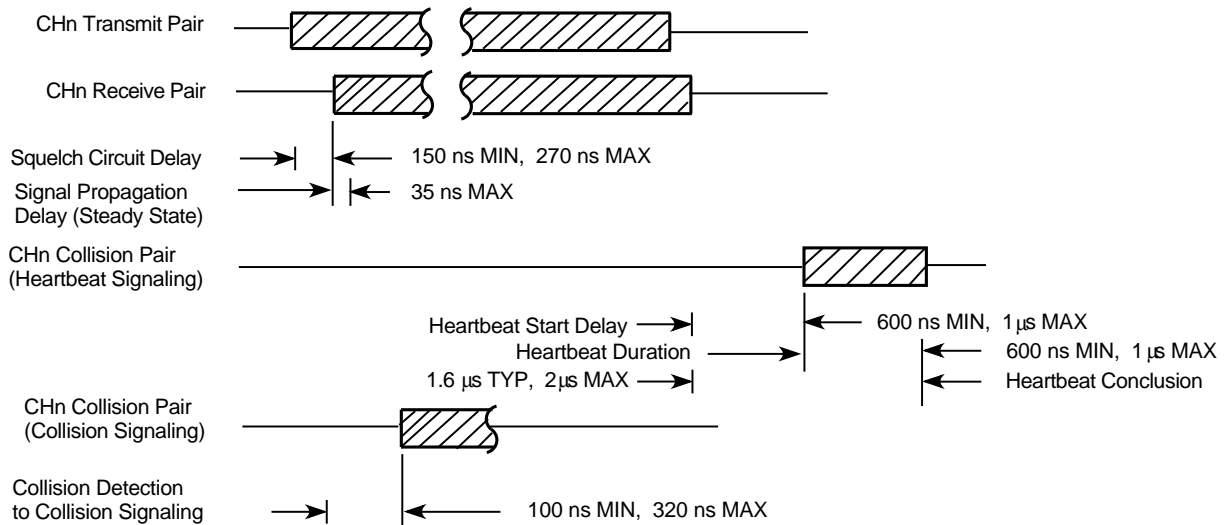

MKV-040000202-32-RAGS

3.2.2 GLOBAL Mode Signal Flow and Timing Relationships

In the GLOBAL mode of operation, the signal asserted on a CHn TRANSMIT pair is routed to the XCVR TRANSMIT pair (Figure 3–3).

The time delay between the assertion of the CHn TRANSMIT pair signal and the assertion of the XCVR TRANSMIT pair signal is due to the DELNI squelch circuit characteristics (Figure 3–4). The time delay between the data content of the CHn TRANSMIT pair signal and the data content of the XCVR TRANSMIT pair signal is due to steady-state propagation delay through the DELNI unit.

The signal being asserted on the XCVR TRANSMIT pair is routed back to the XCVR RECEIVE pair by the global network device (MAU).

The time delay between the assertion of the XCVR TRANSMIT pair signal and the assertion of the XCVR RECEIVE pair signal is due to the DELNI squelch circuit characteristics, and the functioning of the global network device. Therefore, only the maximum allowable delay is specified in Figure 3–4.

The global network device detects all global network transmissions and sends the detected data to the XCVR RECEIVE pair of the DELNI unit.

The DELNI unit detects the signals asserted on the XCVR RECEIVE pair and routes the signals to all CHn RECEIVE pairs.

The time delay between the assertion of the XCVR RECEIVE pair signal and the assertion of the CHn RECEIVE pairs signal is due to the DELNI squelch circuit characteristics. The time delay between the data content of the XCVR RECEIVE pair signal and the data content of the CHn RECEIVE pairs signal is due to the steady-state propagation delay through the DELNI unit.

For global heartbeat and collision signaling, the global network device asserts the XCVR COLLISION PRESENCE pair.

DELNI Interfaces, Input/Output Signal Flow, and Specifications

The DELNI unit responds to a signal asserted on the XCVR COLLISION PRESENCE pair by generating and asserting a 10 MHz signal on all CHn COLLISION PRESENCE pairs.

The time delay between the assertion of the XCVR COLLISION PRESENCE pair signal and the assertion of the CHn COLLISION PRESENCE pairs signal is due to the DELNI squelch circuit characteristics.

The DELNI unit also responds to local collision conditions during the GLOBAL mode of operation.

When a local collision condition is detected, the DELNI unit interrupts the normal data path to the XCVR TRANSMIT pair and asserts a 5 MHz signal on the XCVR TRANSMIT pair. This ensures that a signal that meets Ethernet requirements is asserted on the XCVR TRANSMIT pair. The 5 MHz signal remains asserted until the conflicting CHn TRANSMIT pairs are deasserted.

For local collision condition signaling, the DELNI unit generates and asserts a 10 MHz signal on all CHn COLLISION PRESENCE pairs. Local collision signaling starts when the signal transmitted on the XCVR TRANSMIT pair has been looped back to the XCVR RECEIVE pair by the global network device, and the received signal has been detected by the DELNI unit. The 10 MHz signal sent on the CHn COLLISION PRESENCE pairs remains asserted until the conflicting CHn TRANSMIT pairs are deasserted. Therefore, only the maximum time interval between local collision detection and the start of local collision condition signaling is specified in Figure 3-4.

DELNI Interfaces, Input/Output Signal Flow, and Specifications

Figure 3-3 GLOBAL Mode Signal Flow Diagram

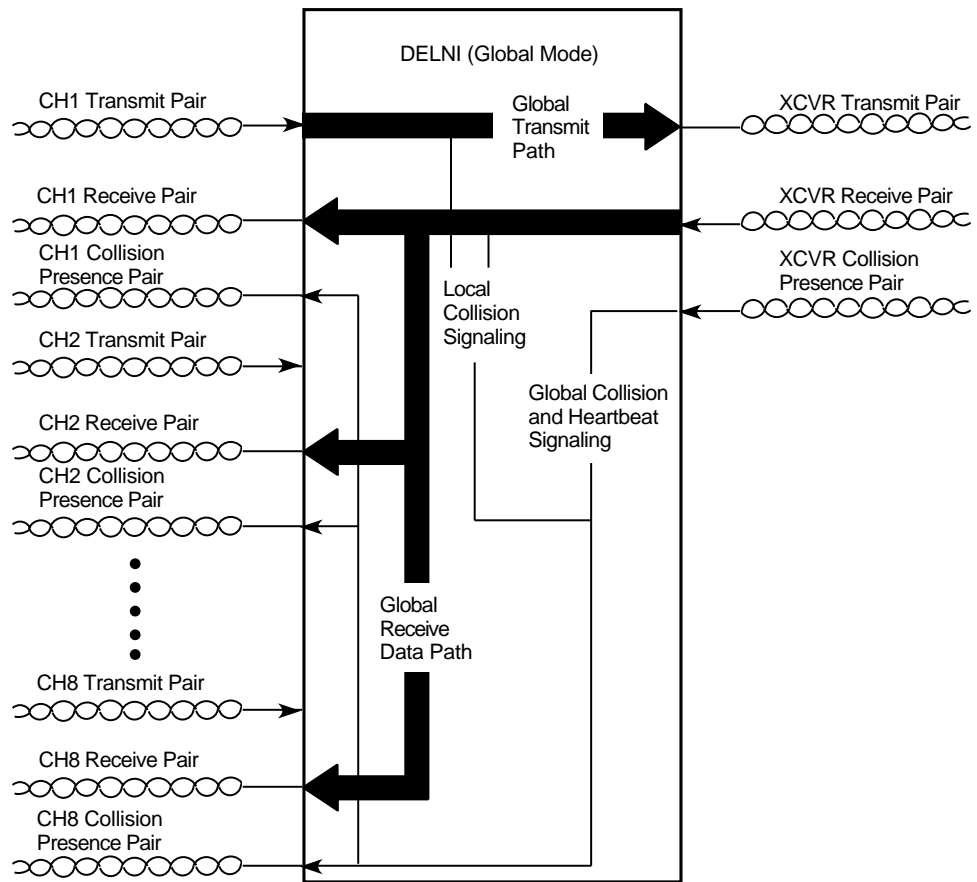

MKV-04000202-33-RAGS

DELNI Interfaces, Input/Output Signal Flow, and Specifications

Figure 3–4 GLOBAL Mode Signal Timing Diagram

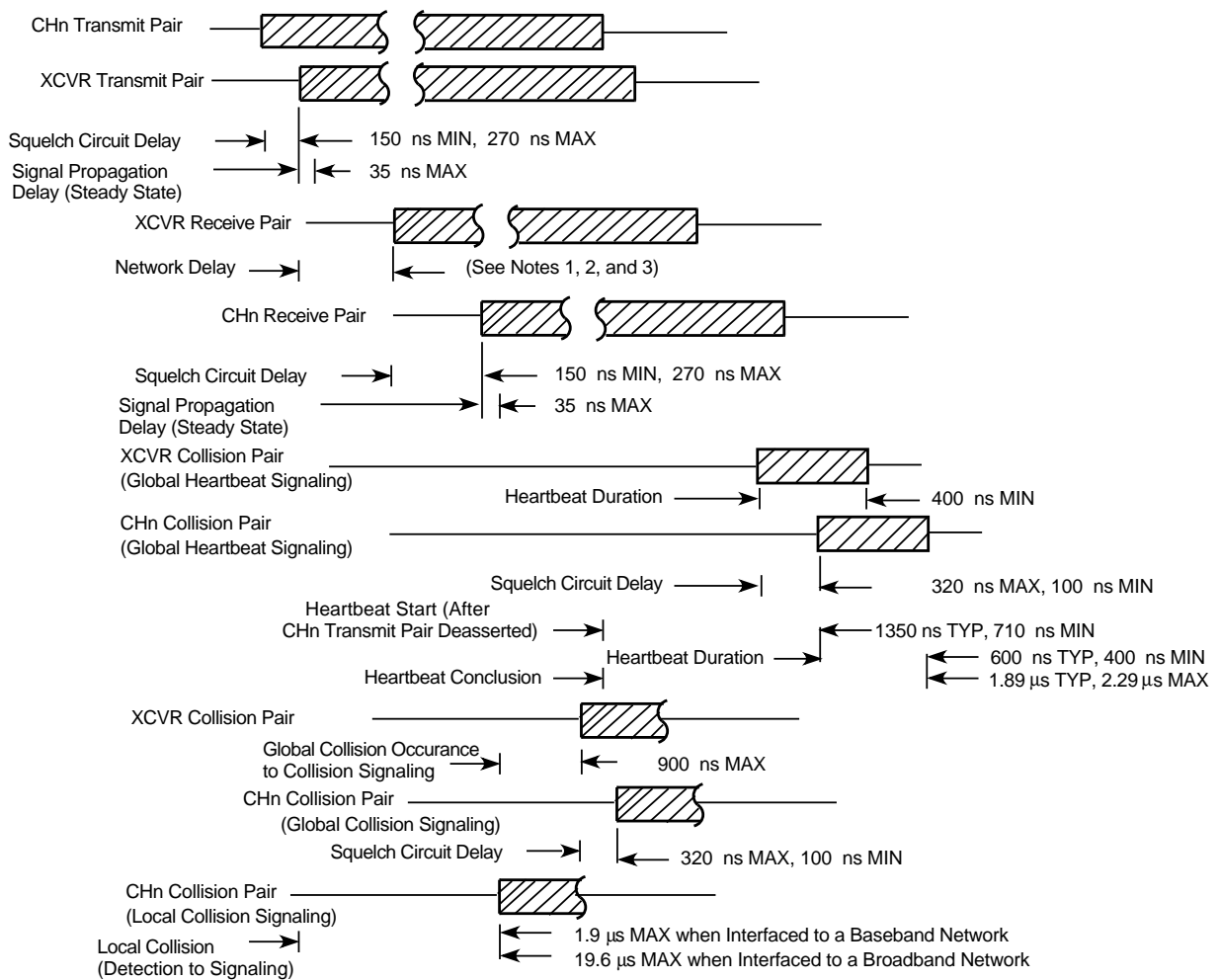

NOTES

- 1 In the Two-Tier DELNI Environment, the Delay will be 818 ns MAX, Which Includes Delays as Follows:
 - 50 m Transceiver Cable (5.13 ns/m); Round-Trip Delay 513 ns
 - Squelch Turn-on Delay of DELNI Unit 270 ns MAX
 - Steady-state Delay Through DELNI Unit 35 ns MAX
- 2 In a Connected DELNI LAN Environment the Delay is 930 ns MAX.
- 3 In a Connected DELNI LAN Environment, Which Interfaces to a Broadband Network, the Delay is 19.6 μs MAX.

MKV-040000202-34-RAGS

3.3 Input/Output Circuit and Signal Characteristics

3.3.1 CH_n TRANSMIT Pair Circuit Characteristics

The CH_n TRANSMIT pair is transformer-coupled to the AUI concentrator chip (ACC).

The characteristics of the circuitry associated with the CH_n TRANSMIT pair are as follows:

- Input impedance
 - Differential mode @10 MHz $78 \pm 3.9 \Omega$
 - Common mode (3 MHz to 20 MHz) 18.5Ω minimum
- Isolation transformer
 - Magnetizing inductance $30 \mu\text{H} \pm 10\%$
 - Isolation withstanding voltage 270 V rms minimum
 - Common mode voltage $\pm 3 \text{ V}$
- Squelch parameters
 - The squelch circuit in the ACC turns OFF only in response to valid Ethernet signals, remains OFF during the transmission interval, and turns ON again after the end of the transmission interval. While the squelch is OFF, it allows the data asserted on the CH_n TRANSMIT pair to pass through the ACC onto the CH_n RECEIVE pair.
 - The squelch circuit has three parameters: turn-off, stay-off, and turn-on. The following information specifies squelch action relative to input signal parameters. Note that in the following list of parameters, -400 is less than -500 .

Turn-off voltage	-350 mV typical, -400 mV minimum
Turn-off time	150 ns minimum, 270 ns maximum
Stay-off time	144 ns maximum
Turn-on time	144 ns minimum, 200 ns maximum

3.3.2 CH_n TRANSMIT Pair Signal Characteristics

- DELNI local connector pins
 - CH_n TRANSMIT (+) Pin 3
 - CH_n TRANSMIT (–) Pin 10
- Signal level (measured differentially)
 - 800 mV peak-to-peak minimum
 - 2630 mV peak-to-peak maximum

NOTE

During the idle state, the input voltage to the CH_n TRANSMIT pair must decay to zero. The first transition of the signal asserted on the CH_n TRANSMIT pair must be negative going, and the last transition must be positive going.

3.3.3 CHn RECEIVE Pair Circuit Characteristics

The characteristics of the circuitry associated with the CHn RECEIVE pairs are as follows:

- Source impedance of driver
 - 400 Ω typical
 - 300 Ω minimum
- Isolation transformer
 - Magnetizing inductance 30 $\mu\text{H} \pm 10\%$
 - Isolation withstanding voltage 270 V rms minimum

3.3.4 CHn RECEIVE Pair Signal Characteristics

- DELNI local connector pins
 - CHn RECEIVE (+) Pin 5
 - CHn RECEIVE (–) Pin 12
- Signal level into 78 $\pm 5 \Omega$ (measured differentially)
 - 1200 mV peak-to-peak minimum
 - 2630 mV peak-to-peak maximum
- Timing asymmetry (duty cycle timing variance for a minimum voltage 10 MHz signal having a 50% duty cycle)
 - 1 ns typical
 - 2 ns maximum
- Signal rise/fall time (10% to 90%)
 - 3.5 ns typical
 - 2.0 ns minimum
 - 5.0 ns maximum

NOTE

During the idle state, the output of the circuits driving the CHn RECEIVE pairs is momentarily high. During the idle state, the output voltage decays to zero due to transformer coupling. The first transition of the signal asserted on the CHn RECEIVE pairs is negative going, and the last transition is positive going.

DELNI Interfaces, Input/Output Signal Flow, and Specifications

3.3.5 CHn COLLISION PRESENCE Pair Circuit Characteristics

The characteristics of the circuitry associated with the CHn COLLISION PRESENCE pairs are as follows:

- Source impedance of driver
 - 400 Ω typical
 - 300 Ω minimum
- Isolation transformer
 - Magnetizing inductance 30 $\mu\text{H} \pm 10\%$
 - Isolation withstanding voltage 270 V rms minimum

3.3.6 CHn COLLISION PRESENCE Pair Signal Characteristics

- DELNI local connector pins
 - CHn COLLISION PRESENCE (+) Pin 2
 - CHn COLLISION PRESENCE (–) Pin 9
- Signal level into 78 $\pm 5 \Omega$ (measured differentially)
 - 1200 mV peak-to-peak minimum
 - 2630 mV peak-to-peak maximum
- Signal frequency
 - 10 ± 0.01 MHz
- Duty cycle
 - Between 40%/60% and 60%/40%
- Signal rise/fall time (10% to 90%)
 - 3.5 ns typical
 - 2.0 ns minimum
 - 5.0 ns maximum

NOTE

During the idle state, the output of the circuits driving the CHn COLLISION PRESENCE pairs is momentarily high. During the idle state, the output voltage decays to zero due to transformer coupling.

3.3.7 XCVR TRANSMIT Pair Circuit Characteristics

The characteristics of the circuitry associated with the XCVR TRANSMIT pair are as follows:

- Source impedance of driver
 - 400 Ω typical
 - 300 Ω minimum
- Isolation transformer
 - Magnetizing inductance 75 $\mu\text{H} \pm 10\%$
 - Isolation withstanding voltage 270 V rms minimum

3.3.8 XCVR TRANSMIT Pair Signal Characteristics

- DELNI global connector pins
 - XCVR TRANSMIT (+) Pin 3
 - XCVR TRANSMIT (–) Pin 10
- Signal level into 78 $\pm 5 \Omega$ (measured differentially)
 - 1200 mV peak-to-peak minimum
 - 2630 mV peak-to-peak maximum
- Timing asymmetry (duty cycle timing variance for a minimum voltage 10 MHz signal having a 50% duty cycle)
 - 1 ns typical
 - 2 ns maximum
- Signal rise/fall time (10% to 90%)
 - 3.5 ns typical
 - 2.0 ns minimum
 - 5.0 ns maximum

NOTE

During the idle state, the output of the circuit driving the XCVR TRANSMIT pair is momentarily high. During the idle state, the output voltage decays to zero due to transformer coupling in the network device to which the signal is asserted. The first transition of the signal asserted on the XCVR TRANSMIT pair is negative going, and the last transition is positive going.

DELNI Interfaces, Input/Output Signal Flow, and Specifications

3.3.9 XCVR RECEIVE Pair Circuit Characteristics

The XCVR RECEIVE pair is transformer-coupled to the AUI concentrator chip (ACC).

The characteristics of the circuitry associated with the XCVR RECEIVE pair are as follows:

- Input impedance
 - Differential mode @10 MHz $78 \pm 3.9 \Omega$
 - Common mode (3 MHz to 20 MHz) 18.5Ω minimum
- Isolation transformer
 - Magnetizing inductance $75 \mu\text{H} \pm 10\%$
 - Isolation withstanding voltage 270 V rms minimum
- Common mode voltage (relative to 12 V return line)
 - +1.0 V minimum
 - +4.2 V maximum
- Squelch parameters
 - Same as specified for the CHn TRANSMIT pair (refer to Section 3.3.1).

3.3.10 XCVR RECEIVE Pair Signal Characteristics

- DELNI global connector pins
 - XCVR RECEIVE (+) Pin 5
 - XCVR RECEIVE (–) Pin 12
- Signal level (measured differentially)
 - 800 mV peak-to-peak minimum
 - 2630 mV peak-to-peak maximum

NOTE

During the idle state, the output of the circuit driving the XCVR RECEIVE pair is momentarily high. During the idle state, the output voltage decays to zero due to transformer coupling. The first transition of the signal asserted on the XCVR RECEIVE pair must be negative going, and the last transition must be positive going.

3.3.11 XCVR COLLISION PRESENCE Pair Circuit Characteristics

The XCVR COLLISION PRESENCE pair is transformer-coupled to the AUI concentrator chip (ACC).

The characteristics of the circuitry associated with the XCVR COLLISION PRESENCE pair are as follows:

- Input impedance
 - Differential mode @10 MHz 78 ±3.9 Ω
 - Common mode (3 MHz to 20 MHz) 18.5 Ω minimum
- Isolation transformer
 - Magnetizing inductance 75 μH ±10%
 - Isolation withstanding voltage 270 V rms minimum
- Common mode voltage (relative to 12 V return line)
 - +1.0 V minimum
 - +4.2 V maximum
- Squelch parameters
 - The squelch circuit in the ACC turns OFF only in response to valid Ethernet signals, remains OFF while the signal remains asserted, and turns ON again after the signal input has ended. While the collision presence squelch is turned OFF, it enables the DELNI unit to generate and assert a 10 MHz signal on the CHn COLLISION PRESENCE pairs.
 - The squelch circuit has three parameters: turn-off, stay-off, and turn-on. The following information specifies squelch action relative to input signal parameters. Note that in the following list of parameters, –400 is less than –500.

Turn-off voltage	–350 mV typical, –400 mV minimum
Turn-off time	150 ns minimum, 270 ns maximum
Stay-off time	144 ns maximum
Turn-on time	144 ns minimum, 200 ns maximum

DELNI Interfaces, Input/Output Signal Flow, and Specifications

3.3.12 XCVR COLLISION PRESENCE Pair Signal Characteristics

- DELNI global connector pins
 - XCVR COLLISION PRESENCE (+) Pin 2
 - XCVR COLLISION PRESENCE (–) Pin 9
- Signal level (measured differentially)
 - 800 mV peak-to-peak minimum
 - 2630 mV peak-to-peak maximum

NOTE

During the idle state, the output of the circuit driving the XCVR COLLISION PRESENCE pair must be high. During the idle state, the output voltage decays to zero due to transformer coupling. The first transition of the signal asserted on the XCVR COLLISION PRESENCE pair must be negative going, and the last transition must be positive going.

3.3.13 XCVR POWER Pair Characteristics

The XCVR POWER pair of the DELNI unit provides a +12 V power source for an Ethernet transceiver.

The +12 V power source is short-circuit protected by a current-limiting circuit within the DELNI unit. The power source can withstand an externally applied voltage [to XCVR POWER (+) pin with respect to XCVR POWER (RTN) pin] of +15 V maximum without damage to the power source.

The XCVR POWER pair meets the requirements for Class 2 wiring devices.

The general output characteristics are as follows:

- DELNI global connector pins
 - XCVR POWER (+) Pin 13
 - XCVR POWER (RTN) Pin 6
- Output voltage (V_{out})
 - No load ($I_{out} < I_{min}$)
 - 15 V peak
 - $I_{min} < I_{out} < I_{max}$
 - 12.5 V typical
 - 14.0 V maximum
 - 11.4 V minimum

NOTE

The output voltage is regulated within the given range over the intended operational current range of $I_{out\ min}$ to $I_{out\ max}$. Output current above $I_{out\ max}$ may cause the supply to come out of regulation and reduce the output voltage.

- Output current (I_{out})
 - 0.5 A rms maximum (continuous)
 - 0.0 A rms minimum
- Output current at current limit (output current into 0 V for the current limit mode)
 - 1.5 A rms maximum
- Ripple voltage
 - 0.5 V peak-to-peak (includes both ripple frequency components)
- Ripple frequency
 - 100 kHz typical
 - 110 kHz maximum
 - 80 kHz minimum

NOTE

The output ripple may have two frequency components: one at double the line frequency and one at the power supply switching frequency.

3.3.14 XCVR POWER Pair External Load Requirements

Specific external load requirements are as follows:

- Maximum reactive load
 - Capacitance 2000 μ F
 - Inductance 1 mH
- Maximum continuous load current fluctuations
 - 0 to 20 kHz 200 mA peak-to-peak
 - 20 kHz to 1 MHz 500 mA peak-to-peak

3.4 Input Power Requirements

The input power requirements for the DELNI unit are as follows:

- Voltage/frequency/phase (range is user switch selected)
 - 90-128 Vac/47-63 Hz/single phase
 - 180-256 Vac/47-63 Hz/single phase
- Current (steady state) maximum
 - 0.20 A at 120 Vac
 - 0.11 A at 240 Vac
- Inrush current
 - 10 A at 120 Vac
 - 5 A at 240 Vac
- Surge current
 - 2 A for 5 cycles at 120 Vac
 - 1 A for 5 cycles at 240 Vac
- Apparent power (typical)
 - 14 W at 120 Vac
 - 14 W at 240 Vac
- Maximum power consumption
 - 15 W at 120 Vac
 - 15 W at 240 Vac
- Input power protection
 - Circuit breaker
 - 2 A thermal circuit breaker
 - Internal transformer thermal protection

3.5 Environmental Requirements

The DELNI unit is designed for use in a Digital Equipment Corporation Class C Environment (a non-air conditioned or exposed area in an industrial site).

The specific operational environmental conditions are as follows:

- Temperature
 - 5°C (41°F) to 50°C (122°F)

NOTE

Temperature based on operation at sea level; 760 mm Hg (29.92 in Hg). Maximum allowable temperature is reduced by a factor of 1.8°C/1000 m (1°F/1000 ft) for operation at high-altitude sites.

- Relative humidity
 - 10% or less to 95% with maximum wet bulb 32°C (90°F) and minimum dew point 2°C (36°F).

Theory of Operation

4.1 DELNI Circuit Characteristics

Figure 4–1 shows a functional block diagram of the DELNI unit. As shown, the DELNI unit is made up of the following functional circuits:

- Power supply
- Operating mode control
- AUI concentrator chip (ACC)
- Eight local connector interfaces with each interface containing:
 - Isolation transformers
 - Termination resistors

NOTE

For simplicity, only one of the eight local connector interfaces are shown in Figure 4–1. The STATION DRIVERS EN, CHA RCV DATA, and 10 MHz signals are common to all eight local connector interfaces. The CHA CLSN, CHA XMIT DATA, and CHA XMIT SQLCH signals are individual connections to each local interface.

- Global connector interface that contains:
 - Isolation transformers
 - Termination resistors

4.1.1 Power Supply

The power supply uses an input filter/voltage selection device, a single secondary voltage step-down transformer, a bridge rectifier, and two independent but coupled switching power regulator chips to convert the 120/240 Vac input power to a regulated +5 Vdc and +12 Vdc output. The power regulator chips have internal overvoltage, overcurrent, and overtemperature protection mechanisms. The +5 Vdc output is used to power the ACC. The +12 Vdc output is used to provide power to an Ethernet transceiver.

The two-position slide switch on the front panel makes the DELNI power supply compatible with either a 120 Vac input or a 240 Vac input. The +5 Vdc output of the power supply drives the mode indicator lights (green LEDs) on the front panel of the DELNI unit. Either one of the LEDs being lit indicates that the +5 Vdc power supply is functioning properly. The status of the +12 Vdc power supply is not reflected by the LEDs. If a problem with the +12 Vdc power supply is suspected, refer to the troubleshooting chapter in the *Replacement DELNI Installation and Operating Information* manual.

Theory of Operation

4.1.2 Operating Mode Control

The operating mode control consists of the GLOBAL\LOCAL push button and two green LED indicators located on the front panel of the DELNI unit. GLOBAL mode is selected by pushing the GLOBAL/LOCAL push button until the green LED next to the symbol is lit. LOCAL mode is selected by pushing the GLOBAL/LOCAL push button until the green LED next to the symbol is lit.

4.1.3 AUI Concentrator Chip (ACC)

The ACC functional control logic operates in either of two switch-selectable modes; LOCAL and GLOBAL. Depending on the selected mode, the internal control logic selects the proper internal data path routing and collision handling. The internal data path is only altered prior to enabling external line drivers to guarantee that no data transmission occurs during data path multiplexing.

Two pins on the ACC (TEST and SMARTSQE) are not used in the DELNI unit. Both are asserted low to enable the functions. Internal pullups in the ACC require no external components to disable these functions. TEST is used only for special test functions in the ACC and is not used by the DELNI unit. SMARTSQE is a pin to select whether the SQE signal is sent to all channel collision pairs following a transmit, or only to the channel or channels that were involved in transmitting. The DELNI unit operates with the SMARTSQE pin unconnected to send the SQE signal to all channels following any local transmit. The internal control logic is either asynchronous or is timed off of a 10 MHz base clock depending on performance and synchronization issues. This produces internal state transitions at 100 ns intervals for the synchronous sections.

4.1.4 Local Interfaces

As shown in Figure 4–1, each of the eight local interfaces are connected to:

- The ACC
- Isolation transformers
- Termination resistors

The isolation transformers are used to provide electrical isolation between the DELNI unit and the devices connected to the local connectors.

4.1.5 Global Interface

As shown in Figure 4–1, the global interface is connected to:

- The ACC
- Isolation transformers
- Termination resistors

Figure 4-1 DELNI Functional Block Diagram

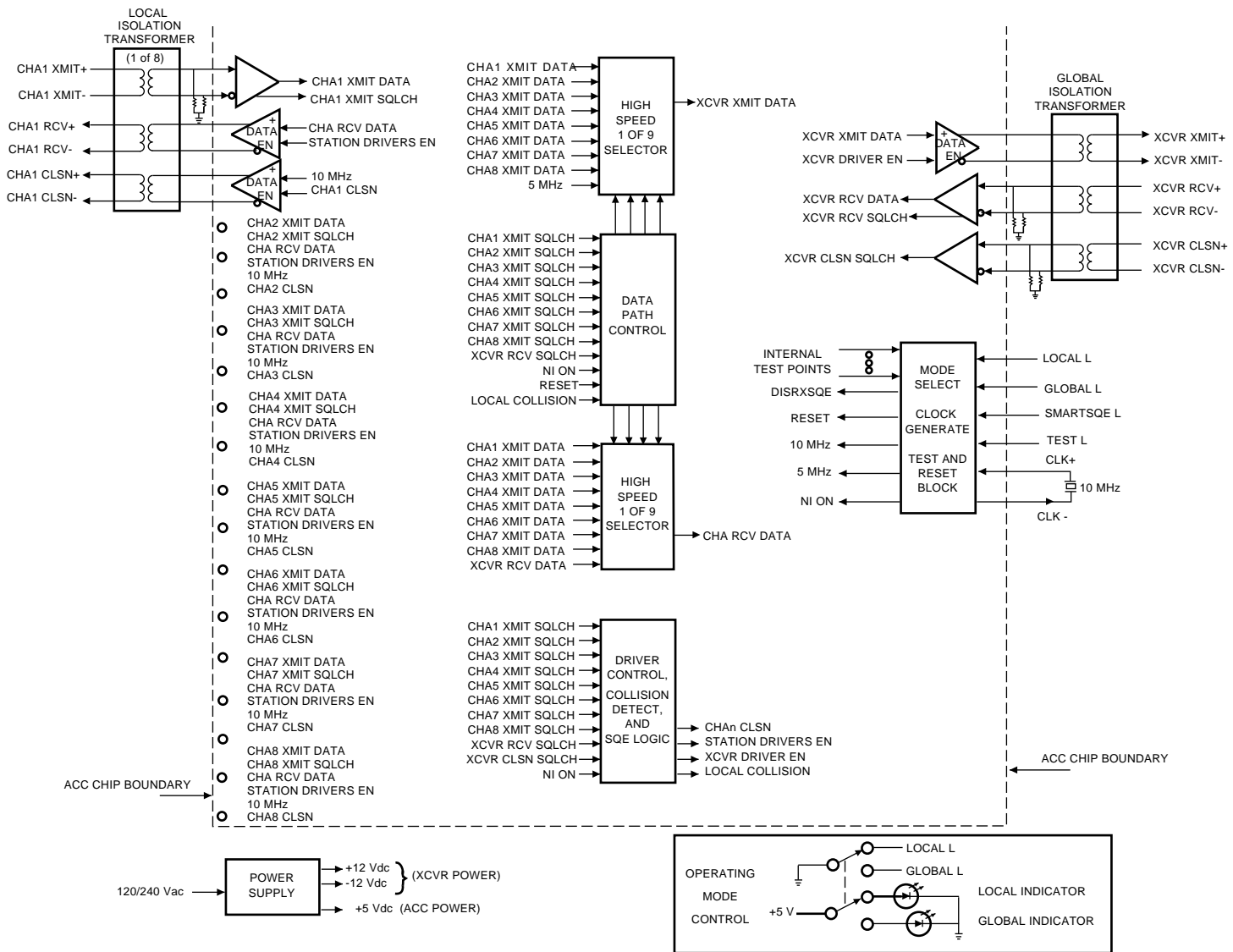

MKV-04000202-36-MPS

Theory of Operation

4.2 DELNI Functional Operation

To provide a cohesive functional theory of operation, the operation of the DELNI unit is discussed relative to the functions performed in each operational mode.

4.2.1 LOCAL Mode Functional Theory

While all CHA XMIT input lines from the stations are inactive, the ACC is in an idle condition. When the ACC is in an idle condition, all CHA RCV and CLSN output drivers to the stations are disabled. This state also occurs when powering up the ACC.

When the ACC is in LOCAL mode, all control signals to and from the XCVR port are logically disabled by the control logic.

When transmission activity that causes squelch deassertion is detected on any of the eight CHA XMIT input pins, the ACC gates that line's transmission data to all CHA RCV drivers and then enables the CHA RCV line drivers to drive the lines. As long as this condition exists, the single CHA XMIT input is routed to all CHA RCV pair drivers.

When the transmission is completed, the squelch for that particular channel activates. This in turn starts the end-of-packet hold on the CHA RCV pair driver outputs on all channels. Once the hold time is met, the drivers transition to an idle state.

During the specified SQE test interval, the ACC internally generates an SQE test burst and sends the burst to the CHA CLSN output lines of all the stations.

If two or more stations become active during any station transmission activity, the ACC immediately recognizes this as a collision. The ACC then activates the CHA CLSN drivers to the stations and places a 10 MHz collision presence signal on all of the CHA CLSN output lines. The CHA RCV data is considered undefined during collision.

To reduce the power dissipation caused by having both the CLSN and RCV drivers active, the RCV drivers shut down once the CLSN drivers are active and they remain shut down until all XMIT activity has completed. This overlap ensures that no carrier dropout occurs. The collision presence signal remains active as long as any station port is detecting transmission input activity. Once all transmission traffic has ceased, the ACC returns to the idle condition.

4.2.2 GLOBAL Mode Functional Theory

When the ACC is set to GLOBAL mode, the local station users are logically connected to the LAN backbone media. Because of this, there are two types of signal flow patterns that can occur; station to other stations and the LAN, or LAN to all stations.

After powerup reset, the ACC enters the idle state and waits for LAN or station line activity to direct its internal data routing sequencer.

If a station starts to transmit, its squelch deactivates and it is considered active. The control logic then selects that channel's data for transmission to the external LAN. Unlike the LOCAL mode of operation, the other stations do not receive the data directly from the active port. Data must first reach the transceiver, be looped back, and then be applied to the eight CHA RCV drivers. This emulates the operation between a station and a transceiver in a normal point-to-point link.

In GLOBAL mode, the ACC must handle local collisions differently than global collisions. For local collisions, the ACC cannot force a collision on the LAN backbone directly. The only thing that can be done is to transmit on the XCVR XMIT leads to force activity onto the LAN segment. This ensures that any LAN activity collides with the forced 5 MHz signal and can be detected on the collision receiver, thus keeping the network in synchronization. Once the XCVR RCV data is looped back from the LAN, the collision is sent to all of the local stations CHA CLSN outputs. Unlike LOCAL mode, the CHA RCV outputs remain active during a collision condition. The CHA RCV outputs transition to idle only after all transmit activity has ended, either from CHA XMIT or XCVR RCV.

A global collision (collision on the network) is handled in the normal manner since a stations transmitted data is routed to the XCVR XMIT data. This causes the actual data sources to be in collision. Once a collision is detected on the network, the transceiver asserts CLSN. CLSN is then detected on the XCVR CLSN input. CLSN is then routed to all of the CHA CLSN outputs, which causes the transmitting station and all others to become aware of the collision.

In GLOBAL mode the transceiver generates SQE. Once a station finishes its transmission, the transceiver generates the SQE. This is detected on the XCVR CLSN input and the SQE is then sent on all the stations' collision lines.

Because of the additional cable length involved for the external transceiver, collision presence is sent to all stations until all station transmission activity and transceiver collision activity ceases. This keeps the local stations more closely synchronized with the global network timing.

