

MicroVAX 3100 Model
30 to DEC 3000 Model
400S AXP

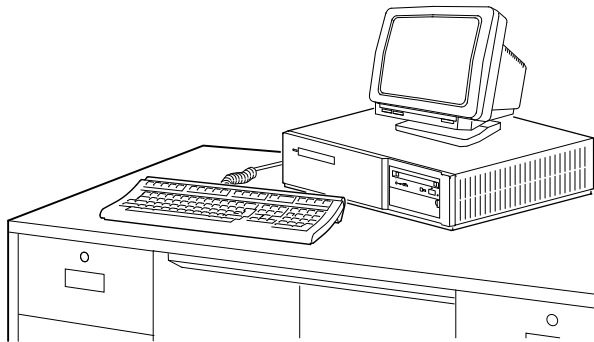

Upgrade Instructions



Part Number: EK-MX34S-IN. A01

Options You Can Upgrade

	Can Upgrade	Cannot Upgrade
Drives:	RZ23L, 24L	RZ22
	RZ24, 25, 26	RZ23
	RZ55*	RZ27
	RZ56*	RZ35
	RZ58*	RZ57
	RX26	RZ59
	TZK10	RX23
	RRD42**	RX33
	TLZ04*	TK50Z
	TLZ06**	DSSI Devices
	TZ85*	
	TZ86***	
	TZ30****	
Expansion Boxes:	SZ03	
	SZ12	
	SZ16	
Memory:	None	
Communication Options:		DHW42
		DSW41

*External device support only.

**External device (including tabletop) support only.

***Support planned for external device.

****Latest version of TZ30 only.

Check Components Shipped

Your shipment should contain the following two kits.

If you are missing any of these components, contact your Digital sales representative.

System Kit:

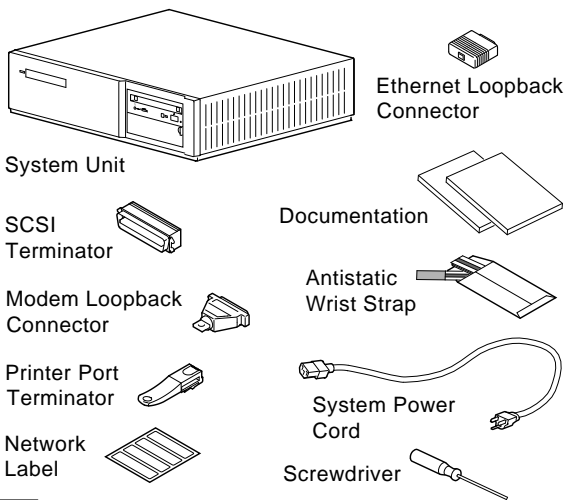

Accessory Kit:

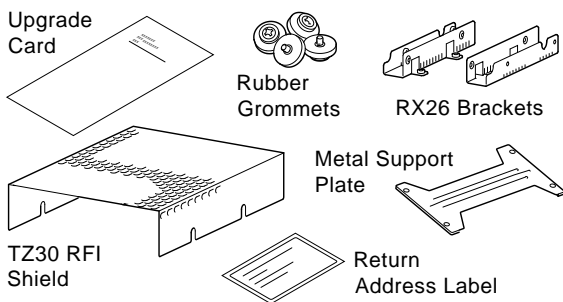

Remove the System Unit Cover

Follow these steps to remove the system unit cover:

1. Turn off the system by pressing the on/off switch to the off (O) position.
2. Disconnect the cables, connectors, and terminators from the system unit.
3. Loosen the two captive screws on the back of the system unit.

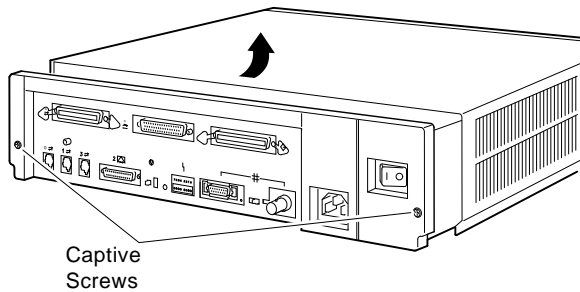

4. Slide the cover forward and lift it up from the system unit. Set the cover aside.

Remove Fixed Disk Drives

Note: The DEC 3000 system can hold two fixed disk drives and one removable-media drive.

1. Press and hold the spring clip that locks the disk drive in position.
2. Push the disk drive towards the spring clip until the rubber grommets under the disk drive release from the cutouts in the drive mounting shelf.

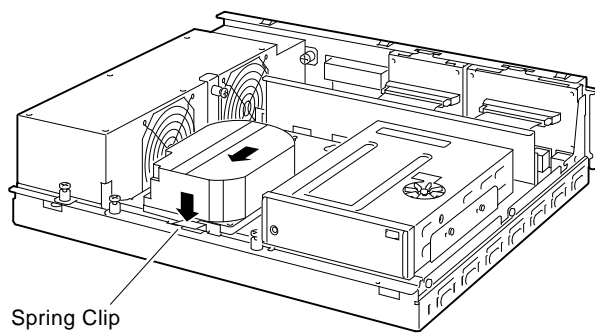

3. Lift the disk drive up from the drive mounting shelf and release the spring clip.
4. Disconnect the SCSI and power cables from the back of the drive.
5. Set the drive aside on an antistatic mat.

Remove Diskette/CD/Tape Drive

Follow these steps to remove a removable-media drive from the lower drive shelf:

1. Loosen the captive screw that secures the drive mounting bracket to the drive shelf.

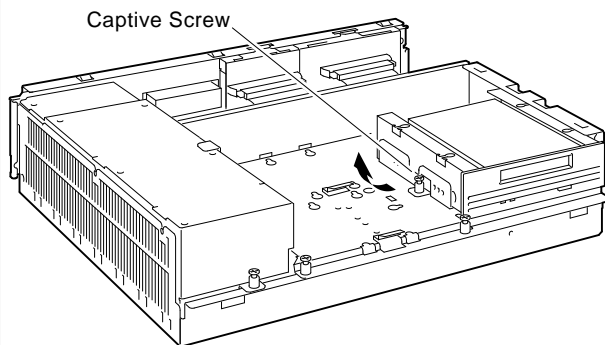

2. Lift the left side of the drive until the tabs on the right side clear the cutouts in the drive shelf.
3. Disconnect the SCSI and power cables from the back of the drive.
4. Set the drive aside on an antistatic mat.

Check the SCSI ID Settings

Each device in your system must have its own unique SCSI ID setting. If your DEC 3000 system has a factory-installed drive, it is set to SCSI ID 3.

You can check the SCSI ID settings on your drives by referring to the *DEC 3000 Model 400/400S AXP Options Guide*. The RZ23L and RZ24 SCSI ID settings (not covered in the guide) are shown here.

RZ23L Drive SCSI ID Settings:

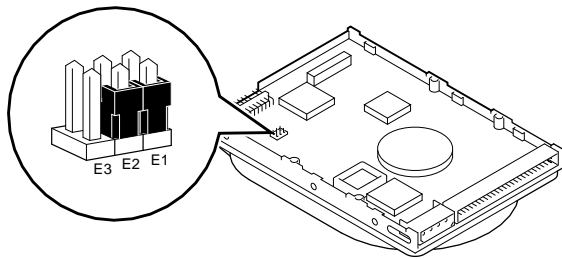

SCSI Settings: 0

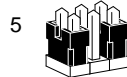

Check the SCSI ID Settings

RZ24 Drive SCSI ID Settings:

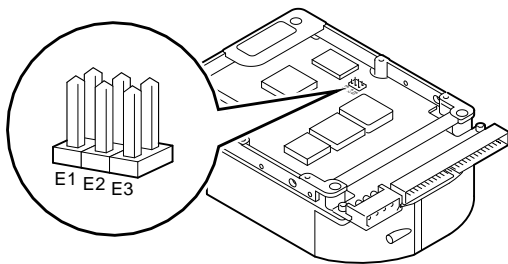

SCSI

Settings: 0



Install New Mounting Brackets

Remove the mounting brackets from all the drives you are upgrading, unless you are upgrading an RZ23L or RZ24 drive that has the support plate shown below.

To attach the support plate (from the accessory kit) to your drives:

1. Place the metal support plate on the disk drive as shown.
2. Screw the four rubber grommets into the plate and the drive until the plate is secure.

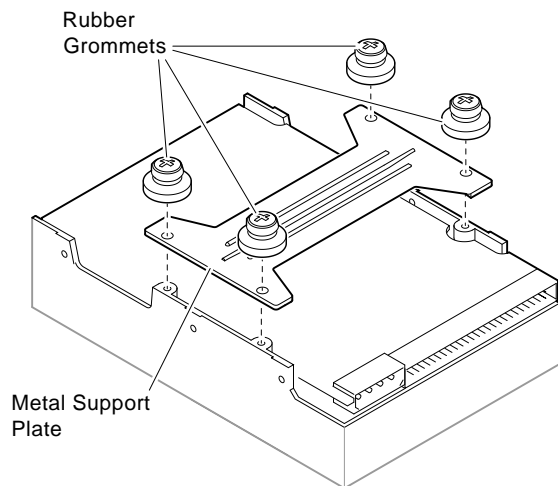

Other Accessory Brackets

Install the RX26 bracket extensions as shown below:

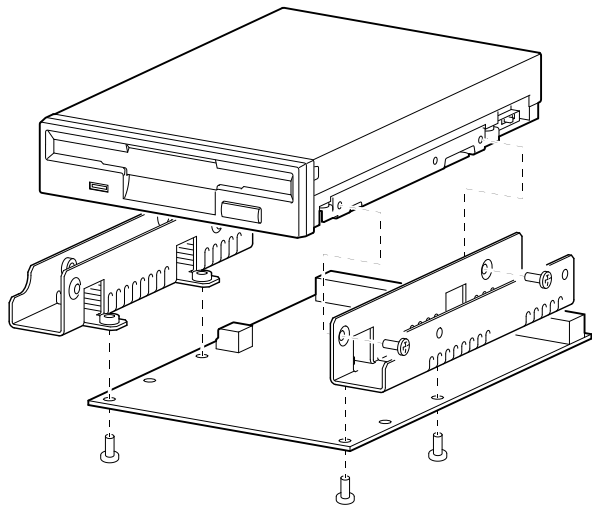

The *DEC 3000 Model 400/400S AXP Options Guide* explains how to attach the RFI shield to the TZ30 drive, and how to mount a removable-media drive in the system mounting bracket.

Install the DEC 3000 System

1. Follow the instructions in the *DEC 3000 Model 400/400S AXP Owner's Guide* to set up and install that system.
2. Follow the instructions in the *DEC 3000 Model 400/400S AXP Options Guide* to install the options in your new system.
3. Connect the terminal, keyboard, and power cables, as shown.

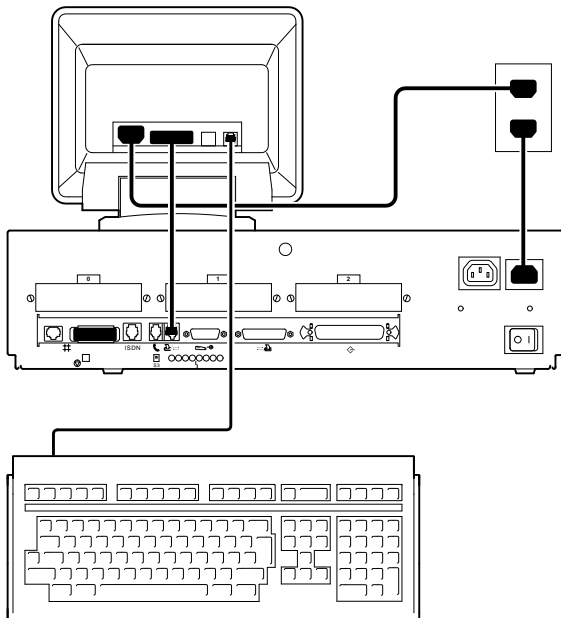

4. Turn on the DEC 3000 AXP system.

Complete the Upgrade

1. Test the installation by turning on your new system and entering the `show device` command at the console prompt.

The drives you upgraded should appear in the display. If a drive does not display, it has not been installed properly.

2. Return your MicroVAX system to Digital as follows:
 - a. Pack the MicroVAX system unit securely in packing material for shipment.
 - b. Attach the return-address label that came in the upgrade accessory kit.
3. Contact your Digital service representative to upgrade your hardware service contract.