

# ZLX Graphics Accelerator Modules

---

## Owner's Guide

Order Number: EK-PIXEL-OG. C01

---

**First Printing, September 1993**  
**Second Printing, November 1994**  
**Third Printing, December 1994**

Digital Equipment Corporation makes no representations that the use of its products in the manner described in this publication will not infringe on existing or future patent rights, nor do the descriptions contained in this publication imply the granting of licenses to make, use, or sell equipment or software in accordance with the description.

The software described in this document is furnished under a license and may be used or copied only in accordance with the terms of such license.

No responsibility is assumed for the use or reliability of software on equipment that is not supplied by Digital Equipment Corporation or its affiliated companies.

© Digital Equipment Corporation 1994.  
All Rights Reserved.  
Printed in U.S.A.

The postpaid Reader's Comments form at the end of this document request your critical evaluation to assist in preparing future documentation.

The following are trademarks of Digital Equipment Corporation: Alpha AXP, AXP, DEC, DEC Open3D, Digital, OpenVMS, TURBOchannel, VAX DOCUMENT, and the DIGITAL logo.

OSF/1 is a trademark of the Open Software Foundation, Inc.

All other trademarks and registered trademarks are the property of their respective holders.

**FCC NOTICE:** This equipment has been tested and found to comply with the limits for a Class A digital device, pursuant to Part 15 of the FCC Rules. These limits are designed to provide reasonable protection against harmful interference when the equipment is operated in a commercial environment. This equipment generates, uses, and can radiate radio frequency energy and, if not installed and used in accordance with the instruction manual, may cause harmful interference to radio communications. Operation of this equipment in a residential area is likely to cause harmful interference, in which case users will be required to correct the interference at their own expense.

S2712

This document was prepared using VAX DOCUMENT Version 2.1.

---

# Contents

Guide Overview .....	1
Purpose .....	1
Audience .....	1
Contents .....	1
Conventions .....	1
Description of the Modules .....	2
Purpose .....	2
Module Variations .....	2
Software .....	2
Monitors .....	2
Illustrations .....	3
Setting Jumpers .....	4
Two Jumpers .....	4
Monitor Jumper .....	4
EEPROM Jumper .....	5
Installation .....	6
Confirming Proper Installation .....	7
Procedure .....	7
Running Self-Tests .....	8
Console Mode .....	8
Command Format .....	8
Available Module Tests .....	8
Available Scripts .....	10
Stereo Viewing .....	11
Stereo Monitor .....	11
Appendix A - Handling Problems Worksheet .....	12
Appendix B - Module Layouts .....	13
PMAGC-DA .....	13
PMAGC-EA .....	14
Appendix C - For Digital Service Use .....	15
FRU/Order Numbers .....	15
Power Up Self-Test (POST) .....	15
Error Message Format .....	15

Other Error Messages .....	15
Firmware Updates .....	16
Module Support .....	16

## Figures

1	ZLX-L1 and ZLX-L2 Graphics Accelerator Modules .....	3
2	L1 and L2 Monitor Jumpers .....	4
3	L1 and L2 EEPROM Jumper Location .....	5

## Tables

1	Module Variations .....	2
2	Software Versions .....	2
3	Self-Tests .....	8
4	Scripts .....	10
5	Module FRUs .....	15
6	Minimum Required Revision Levels .....	16

---

## Guide Overview

<b>Purpose</b>	This guide provides general information on the ZLX graphics accelerator modules (PMAGC–DA, and PMAGC–EA), and specific information for servicing the modules. The information is independent of hardware platform. For hardware installation information, see your hardware systems documentation.						
<b>Audience</b>	This guide is intended for anyone seeking general information on the ZLX modules, and for Digital service personnel seeking specific service information.						
<b>Contents</b>	This guide provides the following information: <ul style="list-style-type: none"><li>• Description of the module</li><li>• Setting jumpers</li><li>• Installation</li><li>• Confirming proper installation</li><li>• Running self-tests</li><li>• Stereo viewing</li><li>• Module layouts</li><li>• Information for Digital service engineers</li></ul>						
<b>Conventions</b>	The following conventions are used in this guide: <table><tr><td>lowercase</td><td>Lowercase monospaced letters indicate a command that you must enter exactly as shown. For example: the <code>show config</code> command.</td></tr><tr><td><b>CAUTION:</b></td><td>Cautions provide information to prevent damage to equipment or software. Read these carefully.</td></tr><tr><td><b>IMPORTANT:</b></td><td>Important notations provide information to allow your system to work properly.</td></tr></table>	lowercase	Lowercase monospaced letters indicate a command that you must enter exactly as shown. For example: the <code>show config</code> command.	<b>CAUTION:</b>	Cautions provide information to prevent damage to equipment or software. Read these carefully.	<b>IMPORTANT:</b>	Important notations provide information to allow your system to work properly.
lowercase	Lowercase monospaced letters indicate a command that you must enter exactly as shown. For example: the <code>show config</code> command.						
<b>CAUTION:</b>	Cautions provide information to prevent damage to equipment or software. Read these carefully.						
<b>IMPORTANT:</b>	Important notations provide information to allow your system to work properly.						

---

## Description of the Modules

**Purpose** The ZLX graphics accelerator modules are TURBOchannel-based 2D/3D graphics accelerators. They enable the use of applications requiring accelerated 2D or 3D graphics, such as mechanical CAD, molecular modeling, scientific visualization, simulation, and animation. When used with the J300 Sound and Motion module, the ZLX graphics accelerator modules integrate graphics with multimedia applications.

**Module Variations** There are two variations of the ZLX graphics accelerator module, as summarized in Table 1.

**Table 1 Module Variations**

Designation	Order No.	Occupies	Memory
ZLX-L1 Module	PMAGC-DA	2 slots	4 Mpixels
ZLX-L2 Module	PMAGC-EA	3 slots	8 Mpixels

**Software** The ZLX graphics accelerator modules require DEC Open3D software and the appropriate operating system version, as shown in Table 2.

**Table 2 Software Versions**

Module Variation	Open3D Software	DEC OSF/1 Software	OpenVMS Software
ZLX L1	2.4	3.0	6.1
ZLX L2	2.4	3.0	6.1

Refer to the DEC Open3D installation guide for software installation procedures.

**Monitors** The ZLX graphics accelerator modules support 66 Hz monitors, such as the VRT19-D and VRT16-D, and 72 Hz monitors, such as the VRT19-H and the VRT16-H.

**Illustrations**

The ZLX-L1 and ZLX-L2 modules are shown in Figure 1.

**Figure 1 ZLX-L1 and ZLX-L2 Graphics Accelerator Modules**

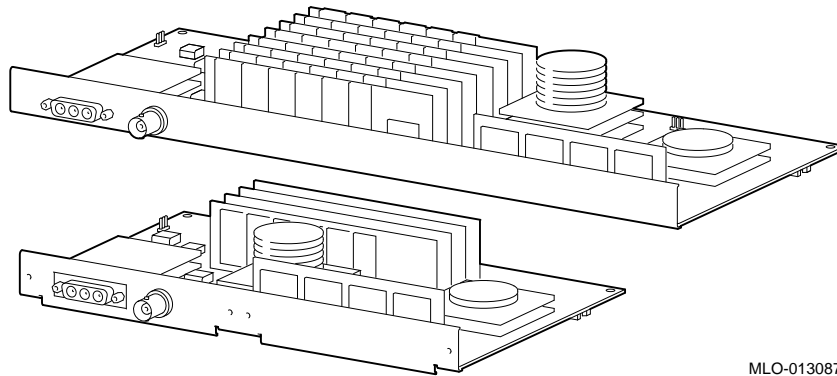

MLO-013087

---

## Setting Jumpers

### Two Jumpers

The ZLX graphics accelerator modules contain two configurable parts, a jumper for selecting the monitor, and a jumper for updating the EEPROM firmware. The locations of these jumpers are shown in Figure 2, and Figure 3.

### Monitor Jumper

Monitor jumpers allow the ZLX graphics accelerator module to work with monitors that use 66 Hz and 72 Hz refresh rates. Set the jumpers as shown in Figure 2.

**Figure 2 L1 and L2 Monitor Jumpers**

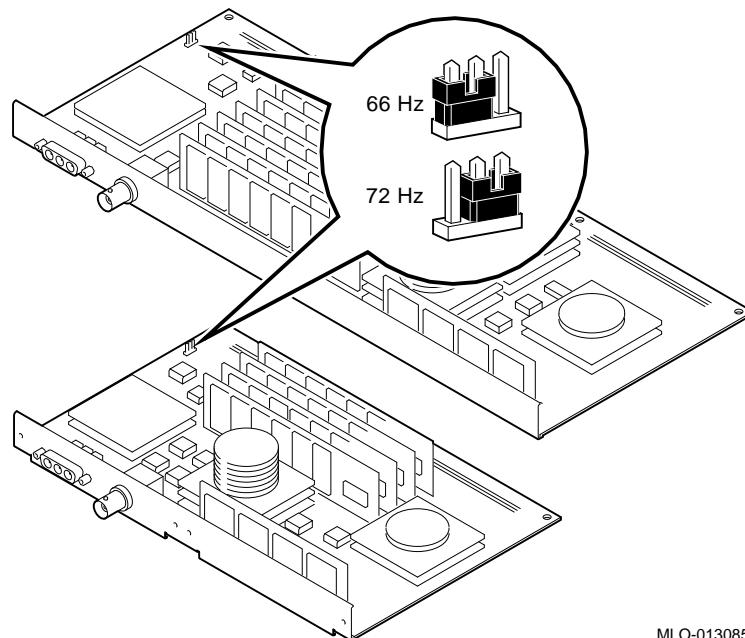

MLO-013085



## EEPROM Jumper

The jumper for the EEPROM is normally in the position shown in Figure 3. To prevent firmware from being changed, move the jumper to the other position.

**Figure 3 L1 and L2 EEPROM Jumper Location**

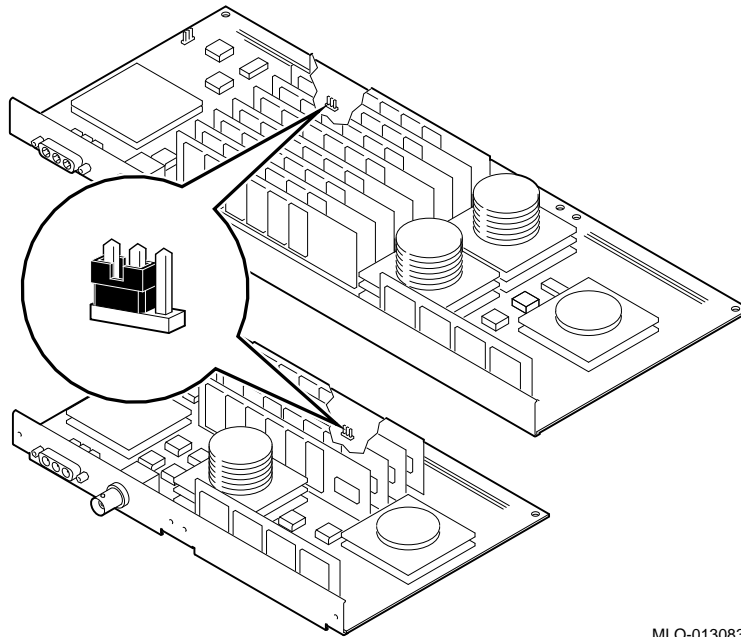

MLO-013083

---

## Installation

See the system documentation, or options documentation, that came with your workstation for installation instructions.

\_\_\_\_\_ **CAUTION: Module Damage** \_\_\_\_\_

To avoid damage from static discharge, you must wear an antistatic wrist strap. Instructions for use are on the strap envelope.

---

\_\_\_\_\_ **IMPORTANT: Grounding Module** \_\_\_\_\_

When installing a module inside a system, make sure that you use the screws that came with the module to fasten the module to the enclosure, thus grounding the module.

---

---

## Confirming Proper Installation

### Procedure

To confirm that the module is installed properly, do the following:

Step	Action
1	Turn on the monitor.
2	Turn on any peripheral devices connected to the system unit.
3	Turn on the system.
4	Enter the <code>sho config</code> command.

**Successful Installation:** PMAGC, PMAGC-DA, or PMAGC-EA appears in the configuration display and no errors are reported.

**Unsuccessful Installation:** The module designation does not appear in the configuration display. Move the module to another slot and try again. If the module still does not appear in the configuration display, contact your Digital service representative.

---

## Running Self-Tests

**Console Mode** Self-tests are run in console mode.

---

**Note**

---

References to slot numbers are used in the examples. Although a module physically occupies 2 or 3 slots, only one of those slots is recognized by the system. This is the slot number that appears in the `sho config` display.

---

**Command Format**

The command format for running a test is `t tc# testname`. For example, for a module residing in TURBOchannel slot 2, to run the `vdac` test, type the following at the prompt:

```
>>> t tc2 vdac
```

**Available Module Tests**

To determine which self-tests are available, type:

```
>>> t tc2 ?
```

`tc2` is the TURBOchannel slot used for the module.

**Table 3 Self-Tests**

Test	Function
<code>init</code>	Initializes the PMAGC module.
<code>cnfg</code>	Prints PMAGC configuration message. This includes version numbers for firmware and chips, the size of the visible pixel map ( <code>VSIZE</code> ), the size of the update array ( <code>USIZE</code> ), and the video refresh frequency.
<code>initc</code>	Initializes PMAGC module for console use.

(continued on next page)

**Table 3 (Cont.) Self-Tests**

<b>Test</b>	<b>Function</b>
putc	Draws a character on the console and updates the cursor position. It handles control characters: backspace, newline, and carriage return.
sram	Tests SRAM.
sramaddr	Tests SRAM addressing.
sramv	Tests SRAM.
sramdump	Prints SRAM contents.
vdac	Tests Bt463 I/O and functionality.
vdacsi	Tests serial input to Bt463.
vdacstat	Prints Bt463 state.
curs	Tests Bt431 I/O.
cursstat	Prints Bt431 state.
fb	Tests VDRAM data bits.
fbaddr	Tests VDRAM addressing.
fbdump	Prints VDRAM contents.
fbinit	Initializes VDRAM.
pva	Tests PVA I/O.
pvaint	Tests PVA interrupts.
pvadma	Tests PVA DMA.
pvatlb	Tests PVA tlb.
pvastat	Prints PVA state.
pv	Tests PV I/O.
pvfunc	Tests PV functionality.
pvstat	Prints PV state.
pat	Displays test patterns.
reset	Toggles reset line on PMAGC module.

## Available Scripts

Scripts are groups of tests and provide a convenient way to run related tests consecutively. You run scripts using the same format as the individual tests.

**Table 4 Scripts**

<b>Name</b>	<b>Function</b>
<code>cnsltest</code>	Tests console functionality. It runs <code>cnsltest</code> for all modules that have a console driver. Tests include <code>opt 1 1</code> , <code>pva 0</code> , <code>vdac 0</code> , <code>fbinit 0 -1</code> , and <code>opt 1 0</code> .
<code>pst-q</code>	Runs quick test of overall functionality. This script is for power-up, not for troubleshooting. Tests include <code>pva1</code> , <code>sram 1</code> , <code>sramaddr</code> , <code> curs 0 1</code> , <code> curs 1 1</code> , <code>vdac 2</code> , <code>pv 1</code> , <code>fbaddr</code> , and <code>fbinit</code> .
<code>pst-t</code>	Runs thorough test of overall functionality. This script is for power-up, not for troubleshooting. Tests include <code>pva1</code> , <code>sram 1</code> , <code>sramaddr</code> , <code> curs 0 1</code> , <code> curs 1 1</code> , <code>vdac 4</code> , <code>pv 1</code> , <code>pvaint 4</code> , <code>pvadma 14 1</code> , <code>pvatlb 7</code> , <code>fb 00000000</code> , <code>fb FFFFFFFF</code> , <code>fbaddr</code> , <code>vdacsi</code> , <code>pvfunc 10</code> , and <code>fbinit</code> .
<code>pst-m</code>	Runs manufacturing test. This script is for troubleshooting, and runs all of the diagnostics. Tests include <code>pva1</code> , <code>sram 3</code> , <code>sramaddr</code> , <code> curs 0 1</code> , <code> curs 1 1</code> , <code>vdac 5</code> , <code>pv 1</code> , <code>pvaint 4</code> , <code>pvadma 14 0</code> , <code>pvadma 14 1</code> , <code>pvatlb 7</code> , <code>fb 00000000</code> , <code>fb FFFFFFFF</code> , <code>fb 55555555</code> , <code>fb AAAAAAAAAA</code> , <code>fbaddr</code> , <code>vdacsi</code> , <code>pvfunc 10</code> , <code>pat</code> , and <code>fbinit</code> .
<code>script tstall</code>	Runs all tests.

---

## **Stereo Viewing**

StereoGraphics, a leading manufacturer of true stereo viewing systems, produces equipment to allow stereo viewing applications to work with your ZLX graphics accelerator module.

For more information, please contact them at:

StereoGraphics  
2171 East Francisco Boulevard  
San Rafael, California 94901  
Telephone: (415) 459-4500  
FAX: (415) 459-3020

## **Stereo Monitor**

Stereo viewing requires that the video monitor support a special stereo frequency mode. The VRC21-HA/H4 video monitor supports this stereo mode as well as video monitors available from other vendors.

---

## Appendix A - Handling Problems Worksheet

If you have a problem, please fill in the following information before calling for assistance. It will help your Digital representative to identify the problem quickly.

System Name/Model Number? \_\_\_\_\_

System Serial Number? \_\_\_\_\_

Module Information (from `sho config` command)?

\_\_\_\_\_

Operating System & Version? \_\_\_\_\_

DEC Open3D software version? \_\_\_\_\_

Monitor Name/Model Number? \_\_\_\_\_

Setting of Monitor Jumper? \_\_\_\_\_

Setting of EEPROM Jumper? \_\_\_\_\_

Error Received? \_\_\_\_\_

Tests Attempted & Results?

\_\_\_\_\_

\_\_\_\_\_

\_\_\_\_\_

\_\_\_\_\_

\_\_\_\_\_

\_\_\_\_\_

\_\_\_\_\_

\_\_\_\_\_

\_\_\_\_\_



---

## Appendix B - Module Layouts

### PMAGC-DA

The following illustration shows the layout for the PMAGC-DA module.

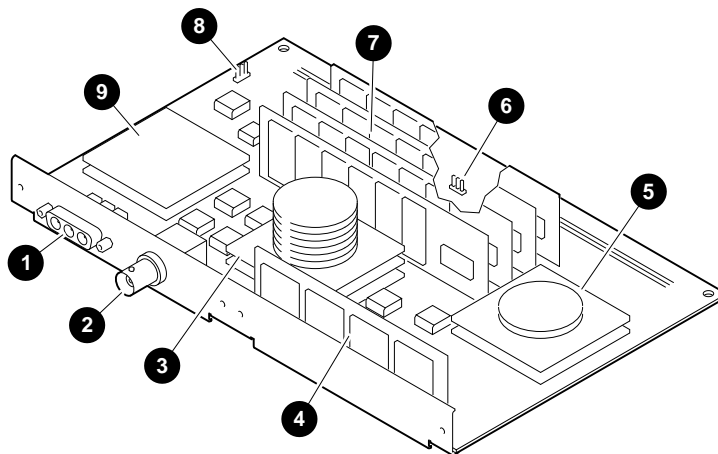

MLO-013082

- ❶ Video port
- ❷ Stereoscopic viewing port
- ❸ Rendering chip
- ❹ Coprocessor memory
- ❺ PVA (ASIC) Chip
- ❻ Flash EEPROM jumper
- ❼ Memory
- ❽ Monitor jumper
- ❾ Video digital/analog converter (VDAC)

## PMAGC-EA

The following illustration shows the layout for the PMAGC-EA module.

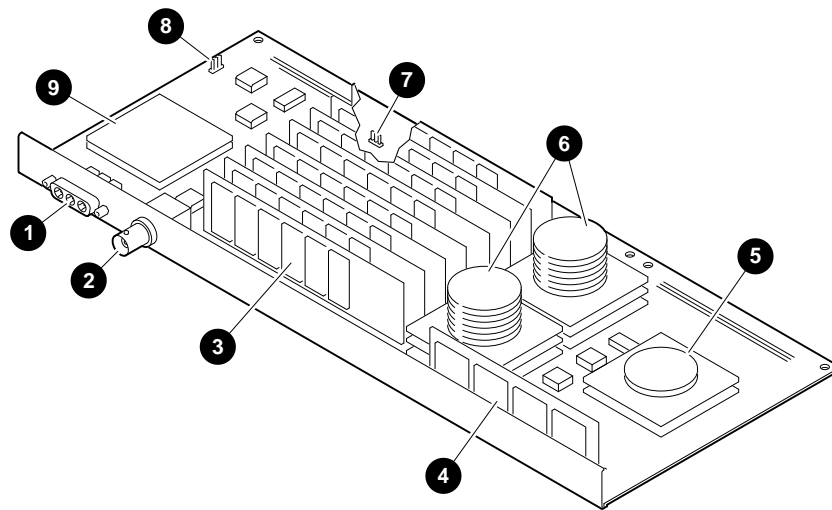

MLO-013081

- ❶ Video port
- ❷ Stereoscopic viewing port
- ❸ Memory
- ❹ Coprocessor memory
- ❺ PVA (ASIC) Chip
- ❻ Rendering chips
- ❼ Flash EEPROM jumper
- ❽ Monitor jumper
- ❾ Video digital/analog converter (VDAC)

---

## Appendix C - For Digital Service Use

### FRU/Order Numbers

See Table 5 to order field replaceable units (FRUs) for the customer.

**Table 5 Module FRUs**

FRU	Order Number
ZLX-L1 Module	54-23767-01
ZLX-L2 Module	54-23769-01
Antistatic wrist strap	12-36175-01
Cable	17-02906-01

### Power Up Self-Test (POST)

The power-up self-test runs the `cns1test`, `pst-q`, `pst-t`, or `pst-m` scripts, depending on the environment variables.

### Error Message Format

Errors use the following format:

```
?TFL: 0/testname(PMAGC) (+1+ yyyyyy)
```

- 0 is the slot number
- testname is the name of the test
- 1 is the test number. If the test has multiple subtests, this is the subtest that failed.
- yyyyyy is the specific test failure information

### Other Error Messages

A "Test not found" error uses the following format:

```
?TNF: testname
```

testname is the name of the test that does not exist.

If the test generates a bus error, the following message appears:

```
?UEX: testname
```

testname is the name of the test that was running when the bus error was generated.

## Firmware Updates

When updating firmware, the EEPROM jumper must be in the "Program" position, as shown in Figure 3. To prevent updates, move the jumper to the other ("Secure") position.

## Module Support

For ZLX graphics accelerator modules support, the system needs to be at a minimum revision level, as shown in Table 6.

**Table 6 Minimum Required Revision Levels**

Platform	Etch Revision	Circuit Revision
DEC 3000 Model 900	SYS B	A01
	IO B	E03
DEC 3000 Model 800	SYS B	B01
	IO A	A01
DEC 3000 Model 700	SYS A	A01
	IO B	A01
DEC 3000 Model 600	SYS A	A02
	IO A	E03
DEC 3000 Model 500	SYS D	J05
	IO F	J06
DEC 3000 Model 400	SYS D	H09
	IO F	H10
DEC 3000 Model 300	SYS C	C05 <sup>1</sup>
	IO D	E01

<sup>1</sup>Revision C modules for Digital internal use only

## How to Order Additional Documentation

---

### Technical Support

If you need help deciding which documentation best meets your needs, call 800-DIGITAL (800-344-4825) and press 2 for technical assistance.

### Electronic Orders

If you wish to place an order through your account at the Electronic Store, dial 800-234-1998, using a modem set to 2400- or 9600-baud. You must be using a VT terminal or terminal emulator set at 8 bits, no parity. If you need assistance using the Electronic Store, call 800-DIGITAL (800-344-4825) and ask for an Electronic Store specialist.

### Telephone and Direct Mail Orders

<b>From</b>	<b>Call</b>	<b>Write</b>
U.S.A.	DECdirect Phone: 800-DIGITAL (800-344-4825) Fax: (603) 884-5597	Digital Equipment Corporation P.O. Box CS2008 Nashua, NH 03061
Puerto Rico	Phone: (809) 781-0505 Fax: (809) 749-8377	Digital Equipment Caribbean, Inc. 3 Digital Plaza, 1st Street Suite 200 Metro Office Park San Juan, Puerto Rico 00920
Canada	Phone: 800-267-6215 Fax: (613) 592-1946	Digital Equipment of Canada Ltd. 100 Herzberg Road Kanata, Ontario, Canada K2K 2A6 Attn: DECdirect Sales
International	—————	Local Digital subsidiary or approved distributor
Internal Orders <sup>1</sup> (for software documentation)	DTN: 264-3030 (603) 884-3030 Fax: (603) 884-3960	U.S. Software Supply Business Digital Equipment Corporation 10 Cotton Road Nashua, NH 03063-1260
Internal Orders (for hardware documentation)	DTN: 264-3030 (603) 884-3030 Fax: (603) 884-3960	U.S. Software Supply Business Digital Equipment Corporation 10 Cotton Road Nashua, NH 03063-1260

---

<sup>1</sup>Call to request an Internal Software Order Form (EN-01740-07).



## Reader's Comments

ZLX Graphics Accelerator Modules  
Owner's Guide

EK-PIXEL-OG. C01

---

Your comments and suggestions help us improve the quality of our publications.

Thank you for your assistance.

<b>I rate this manual's:</b>	<b>Excellent</b>	<b>Good</b>	<b>Fair</b>	<b>Poor</b>
Accuracy (product works as manual says)	<input type="checkbox"/>	<input type="checkbox"/>	<input type="checkbox"/>	<input type="checkbox"/>
Completeness (enough information)	<input type="checkbox"/>	<input type="checkbox"/>	<input type="checkbox"/>	<input type="checkbox"/>
Clarity (easy to understand)	<input type="checkbox"/>	<input type="checkbox"/>	<input type="checkbox"/>	<input type="checkbox"/>
Organization (structure of subject matter)	<input type="checkbox"/>	<input type="checkbox"/>	<input type="checkbox"/>	<input type="checkbox"/>
Figures (useful)	<input type="checkbox"/>	<input type="checkbox"/>	<input type="checkbox"/>	<input type="checkbox"/>
Examples (useful)	<input type="checkbox"/>	<input type="checkbox"/>	<input type="checkbox"/>	<input type="checkbox"/>
Index (ability to find topic)	<input type="checkbox"/>	<input type="checkbox"/>	<input type="checkbox"/>	<input type="checkbox"/>
Page layout (easy to find information)	<input type="checkbox"/>	<input type="checkbox"/>	<input type="checkbox"/>	<input type="checkbox"/>

I would like to see more/less \_\_\_\_\_

\_\_\_\_\_

What I like best about this manual is \_\_\_\_\_

\_\_\_\_\_

What I like least about this manual is \_\_\_\_\_

\_\_\_\_\_

I found the following errors in this manual:

Page	Description
------	-------------

_____	_____
-------	-------

_____	_____
-------	-------

_____	_____
-------	-------

Additional comments or suggestions to improve this manual:

\_\_\_\_\_

\_\_\_\_\_

\_\_\_\_\_

For software manuals, please indicate which version of the software you are using: \_\_\_\_\_

\_\_\_\_\_

Name/Title \_\_\_\_\_ Dept. \_\_\_\_\_

Company \_\_\_\_\_ Date \_\_\_\_\_

Mailing Address \_\_\_\_\_

\_\_\_\_\_ Phone \_\_\_\_\_

Do Not Tear - Fold Here and Tape

**digital**™

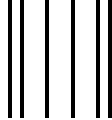

No Postage  
Necessary  
If Mailed  
in the  
United States

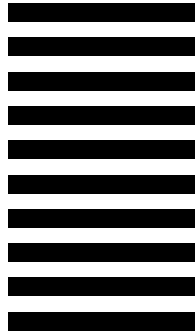

**BUSINESS REPLY MAIL**  
FIRST CLASS PERMIT NO. 33 MAYNARD MASS.

POSTAGE WILL BE PAID BY ADDRESSEE

DIGITAL EQUIPMENT CORPORATION  
Information Design and Consulting  
MRO1-3/K10  
200 FOREST STREET  
MARLBORO, MA 01752-3011



Do Not Tear - Fold Here