

Digital EtherWORKS 3 *Turbo*

User Information

Order Number: EK-LEMAC-OM. B01

Revision/Update Information: This is a revised document.

FCC ID: AO9-DE203
FCC ID: AO9-DE204
FCC ID: AO9-DE205

FCC NOTICE: This device complies with Part 15 of the FCC Rules. Operation is subject to the following conditions: (1) this device may not cause harmful interference, and (2) this device must accept any interference received, including interference that may cause undesired operation.

NOTE: This equipment has been tested and found to comply with the limits for a Class B digital device, pursuant to Part 15 of the FCC rules. These limits are designed to provide reasonable protection against harmful interference in a residential installation.

Any changes or modifications made to this equipment may void the user's authority to operate this equipment.

This equipment generates, uses, and can radiate radio frequency energy and, if not installed and used in accordance with the instructions, may cause harmful interference to radio communications. However, there is no guarantee that interference will not occur in a particular installation. If this equipment does cause harmful interference to radio or television reception, which can be determined by turning the equipment off and on, the user is encouraged to try to correct the interference by one or more of the following measures:

- Re-orient or relocate the receiving antenna
- Increase the separation between the equipment and receiver
- Connect the equipment into an outlet on a circuit different from that to which the receiver is connected
- Consult the dealer or an experienced radio/TV technician for help

The use of unshielded Ethernet cables on ThinWire and thick wire ports with this equipment is prohibited due to non-compliance with FCC regulations for a Class B computing device pursuant to Part 15 of FCC Rules.

This document was prepared using VAX DOCUMENT Version 2.1.

BENUTZERHINWEIS: Das Digital EtherWORKS 3 Turbo-Modul in Verbindung mit Turbo Personalcomputersystemem entsprechen den Funkentstöranforderungen der DBP-Verfugung 523/69 und VDE0871 Grenzwertklasse B.

VCCI Class 2 Notice:

この装置は、第一種情報装置（商工業地域において使用されるべき情報装置）で商工業地域での電波障害防止を目的とした情報処理装置等電波障害自主規制協議会（VCCI）基準に適合しております。

従って、住宅地域またはその隣接した地域で使用すると、ラジオ、テレビジョン受信機等に受信障害を与えることがあります。

取扱説明書に従って正しい取り扱いをして下さい。

First and Second Editions, 1993, 1994

Digital Equipment Corporation makes no representations that the use of its products in the manner described in this publication will not infringe on existing or future patent rights, nor do the descriptions contained in this publication imply the granting of licenses to make, use, or sell equipment or software in accordance with the description.

© Digital Equipment Corporation 1993. All Rights Reserved.
Printed in Australia

The following are trademarks of Digital Equipment Corporation: DEC, EtherWORKS, the DIGITAL logo, PATHWORKS, ThinWire, and VAX DOCUMENT.

IBM is a registered trademark of International Business Machines, Inc.

NetWare is a trademark of Novell Inc.

All other trademarks and registered trademarks are the property of their respective holders.

Contents

| | |
|--|------|
| About This Manual | vii |
| 1 Introduction | |
| Features | 1-1 |
| 2 Board Installation | |
| Preparing your PC | 2-2 |
| Installing a <i>Turbo</i> Board | 2-4 |
| Connecting to an Ethernet Network | 2-7 |
| Selecting the ThinWire and Thick Wire Network Interface | 2-9 |
| Resolving BUS Conflicts on ISA and EISA Systems .. | 2-10 |
| 3 Configuration | |
| Setup/Diagnostic Utility | 3-1 |
| Accessing the Setup/Diagnostic Utility | 3-2 |
| Setup Conventions | 3-2 |
| Default Settings | 3-3 |
| Making Selections from the Setup Menu | 3-4 |
| EISA Configuration | 3-6 |
| EISA Mode Setup | 3-6 |
| Custom Configuration | 3-8 |
| Module Status | 3-10 |
| Exiting NICSETUP | 3-10 |

4 Software Device Driver Installation

| | |
|--|-----|
| NDIS-DOS Device Driver Installation | 4-2 |
| Using Extended Memory Manager | 4-5 |
| ODI Client Device Driver Installation | 4-6 |
| ODI Server Device Driver Installation | 4-7 |
| PATHWORKS Native Datalink Installation | 4-8 |

A Problem Solving

| | |
|----------------------------|-----|
| Isolating Faults | A-2 |
| Error Messages | A-6 |

B General Information

| | |
|--|-----|
| Functional Components | B-1 |
| LEDs | B-2 |
| System Specifications | B-2 |
| Memory Modes | B-3 |
| Memory Mode Addresses | B-3 |
| I/O Base Addresses for the <i>Turbo</i> Boards | B-5 |
| IRQ Values | B-5 |
| Power Requirements | B-6 |
| PC Operating Environment | B-6 |
| Obtaining EtherWORKS Driver Files | B-7 |

Figures

| | | |
|-----|---|-----|
| 1 | <i>Turbo</i> Product Kit (PN DE203-AA) | x |
| 2 | <i>Turbo TP</i> Product Kit (PN DE204-AA) | xi |
| 3 | <i>Turbo PLUS</i> Product Kit (PN DE205-AA) | xii |
| 2-1 | Removing the System Unit Cover | 2-3 |
| 2-2 | Removing the Slot Cover | 2-4 |
| 2-3 | Installing a Board | 2-5 |
| 2-4 | Replacing the Cover | 2-6 |

| | | |
|-----|--|------|
| 2-5 | Connecting to ThinWire, Twisted-Pair, and ThickWire Ethernet | 2-8 |
| 2-6 | Hardstrap Jumpers | 2-12 |
| 4-1 | Distribution Media (Format and Contents) | 4-2 |

Tables

| | | |
|-----|--|------|
| 2-1 | Shunt Connector Settings | 2-9 |
| 2-2 | Hardstrap Override for the <i>Turbo</i> , <i>Turbo TP</i> , and <i>Turbo PLUS</i> Boards | 2-11 |
| 3-1 | Setup/Diagnostic Conventions | 3-2 |
| 3-2 | Default Settings | 3-3 |
| 3-3 | Custom Parameters | 3-8 |
| A-1 | Fault Isolation By Symptom | A-2 |
| A-2 | Error Messages | A-6 |
| B-1 | LED Activity | B-2 |
| B-2 | Memory Mode Addresses | B-4 |
| B-3 | Electrical Parameters | B-6 |

About This Manual

The Digital EtherWORKS 3 *Turbo* boards are personal computer (PC) adapter boards that enable you to integrate IBM compatible PCs to local area network (LAN) environments that use IEEE 802.3 and Ethernet protocols.

This manual explains how to install and configure the Digital EtherWORKS 3 *Turbo* boards (also referred to as *Turbo* board(s) or board in this manual).

The three *Turbo* boards and their connectors are as follows:

- *Turbo*-10BASE2 (ThinWire connector)
- *Turbo TP*-10BASE-T (twisted-pair connector)
- *Turbo PLUS*-10BASE-T, 10BASE2, and 10BASE5 (ThinWire, twisted-pair, and AUI thick wire connectors)

To install the *Turbo* boards, you need to understand the basic concepts and uses of Ethernet networks and be familiar with personal computers.

Manual Organization

This manual contains 4 chapters and 2 appendices.

| Chapter | Description |
|------------|---|
| 1 | Provides an overview of the Digital EtherWORKS 3 <i>Turbo</i> board and briefly describes the board's features. |
| 2 | Describes how to install the <i>Turbo</i> board. |
| 3 | Explains the <i>board</i> configuration. |
| 4 | Contains information about installing the software device drivers. |
| Appendix A | Describes problems you may encounter and suggests possible causes and solutions. |
| Appendix B | Provides system specifications and cabling requirements. |

Manual Conventions

This document uses the following conventions:

| Convention | Meaning |
|---|--|
| Note | A note contains information of special importance to the reader. |
| Caution | A caution contains information to prevent damage to the equipment. |
| PN | Part number. |
| ① | A number in a black circle in text refers to the corresponding number in an accompanying illustration. |
| Enter | A word in a box indicates a key on your keyboard. This example indicates the Enter key. |
| This type | Text in this type indicates text you enter or text that the system displays. |

Product Kit Contents

The product kit should include the items shown in Figure 1, Figure 2, or Figure 3. Verify that you have the following components before proceeding:

- Digital EtherWORKS 3 *Turbo* board ❶.
- Owner's manual ❷.
- Anti-static packaging ❸.
- 3½ inch micro-diskette ❹ that contains the software device drivers, setup utility, and README texts.
- T-Connector ❺ (supplied with the *Turbo* and *Turbo PLUS* boards only).

Figure 1 Turbo Product Kit (PN DE203-AA)

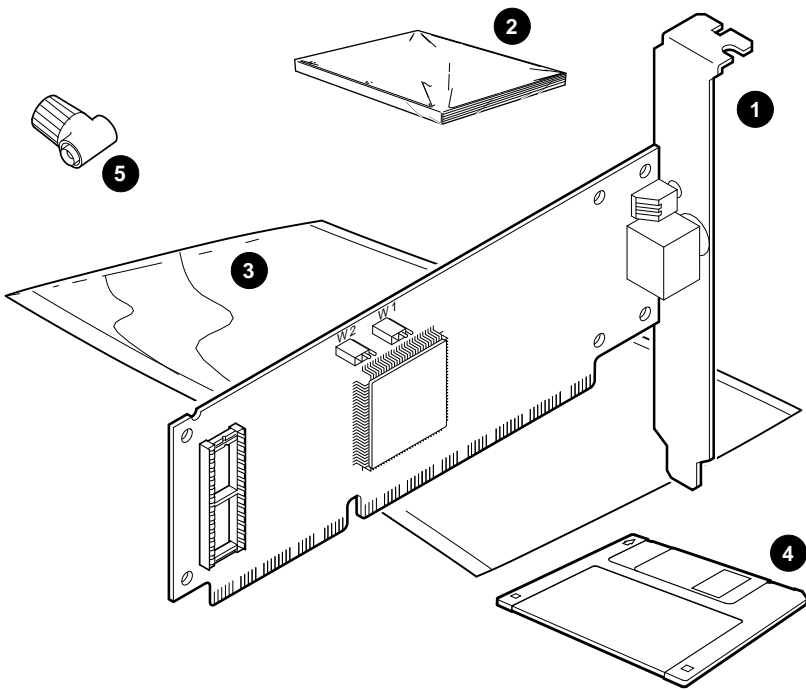

LJ-02592-T10

Figure 2 Turbo TP Product Kit (PN DE204-AA)

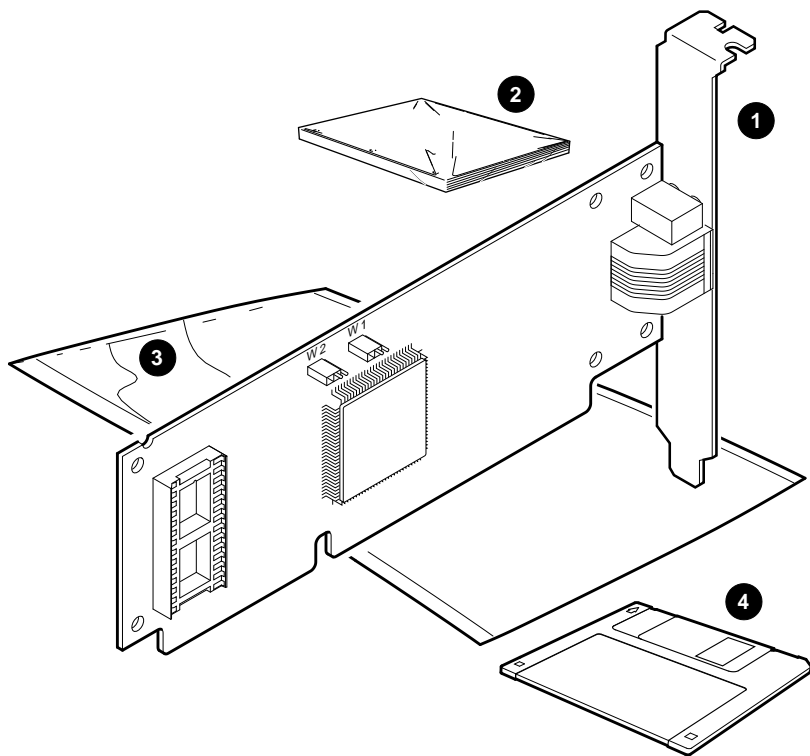

LJ-02621-T10

Figure 3 Turbo PLUS Product Kit (PN DE205-AA)

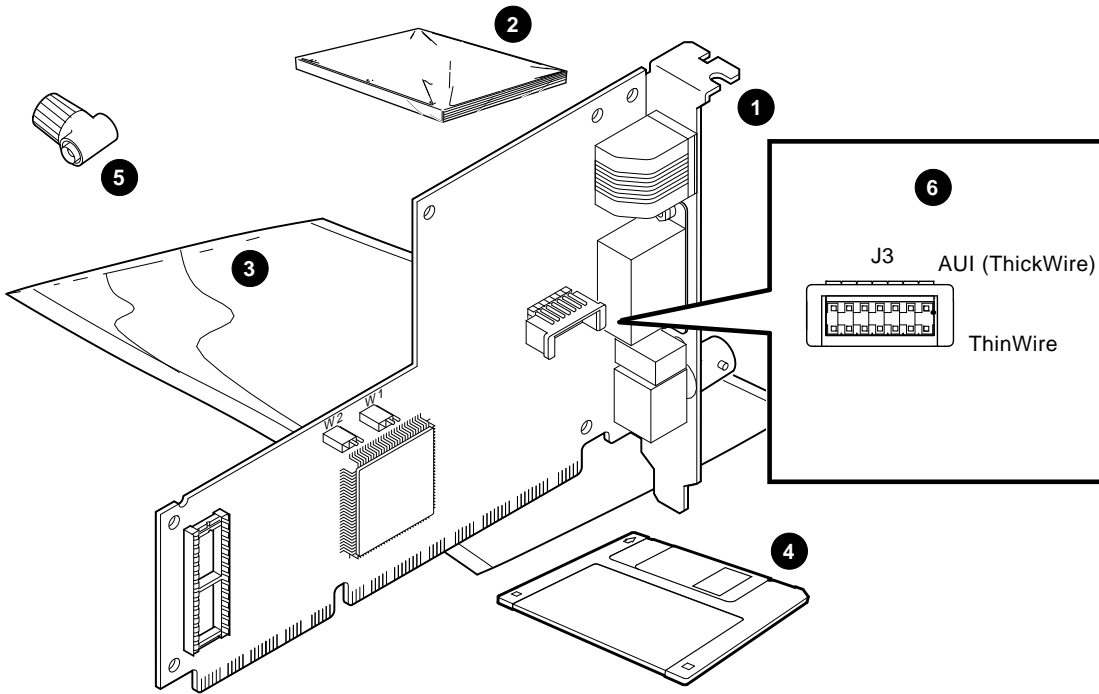

LJ-02623-T10

1

Introduction

This chapter describes the Digital EtherWORKS 3 *Turbo* boards and briefly summarizes the boards' features.

The *Turbo* boards are high-performance controllers that enable PCs to reach file, disk, application, print, and network services from Ethernet networks. The *Turbo* boards support Digital's PATHWORKS network operating system as well as multivendor PC network operating systems through NDIS, ODI, and IPX-compliant software device drivers.

Features

The main features of the *Turbo* boards are as follows:

- Supports Ethernet and IEEE 802.3 industry standards.
- Provides shared memory architecture with dynamic buffer management to ensure maximum performance during heavy network traffic.
- Provides driver and diagnostic programs on a 3½ inch distribution diskette.
- Provides boot ROM option.
- Provides 128 KB onboard RAM, but uses only 2 KB of PC system memory.

2

Board Installation

This chapter explains how to install a Digital EtherWORKS 3 *Turbo* board into your PC. The only tool you need is either a flat-head or Phillips head screwdriver. For instructions on how to disassemble your PC to install the *Turbo* board, refer to the documentation that came with your PC.

Note

Before you begin, make a back-up copy of the diskette that came in the product kit.

Preparing your PC

To prepare your PC for installing the *Turbo* board, perform the following procedure.

Caution

Static electricity can damage printed circuit boards and chips. It is strongly recommended that you use a grounded wrist strap and grounded work-surface-to-earth ground when working with these components.

1. Remove any diskettes from the diskette drives.
2. Set all power switches to O (off).
3. Unplug the power cord from the wall socket, then disconnect the cord from the rear of the system unit.
4. Unplug the keyboard connector from the rear of the system unit.
5. Disconnect any option cables and the monitor cable from the rear of the system unit.

Note

Note where the cables are connected, so you can reconnect them correctly.

6. Remove the screws from the rear of the system unit.
7. Slide the cover toward the front of the system unit until the cover is free (Figure 2-1).

Figure 2-1 Removing the System Unit Cover

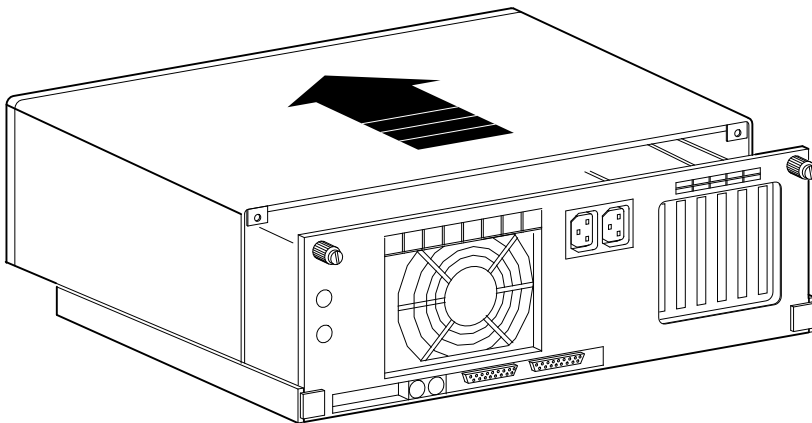

LJ-01814-T10

Installing a *Turbo* Board

Install a *Turbo* board as follows.

Warning

Ensure that there are no missing slot covers when you complete the installation.

1. Remove the option slot cover from the slot you plan to use (Figure 2-2).

Figure 2-2 Removing the Slot Cover

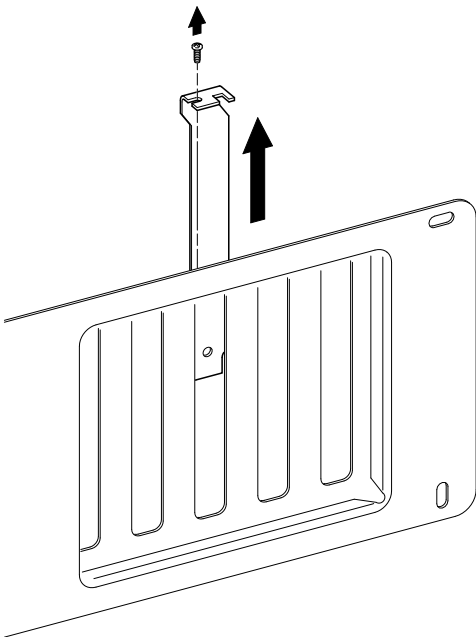

LJ-00462-T10

2. Place the board into the option slot (Figure 2–3).
 - a. Firmly press the board into place until it is securely seated.
 - b. Replace the screw on the slot cover.

Figure 2–3 Installing a Board

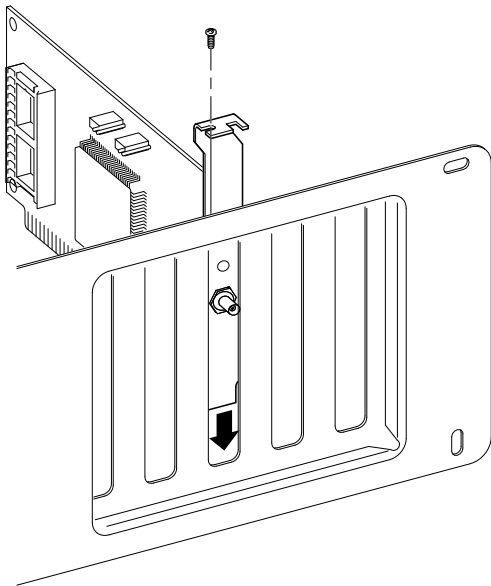

LJ-02590-T10

3. Replace the system unit cover (Figure 2-4).
 - a. Slide the cover toward the rear of the system unit.
 - b. Replace the screws at the rear of the system unit.

Figure 2-4 Replacing the Cover

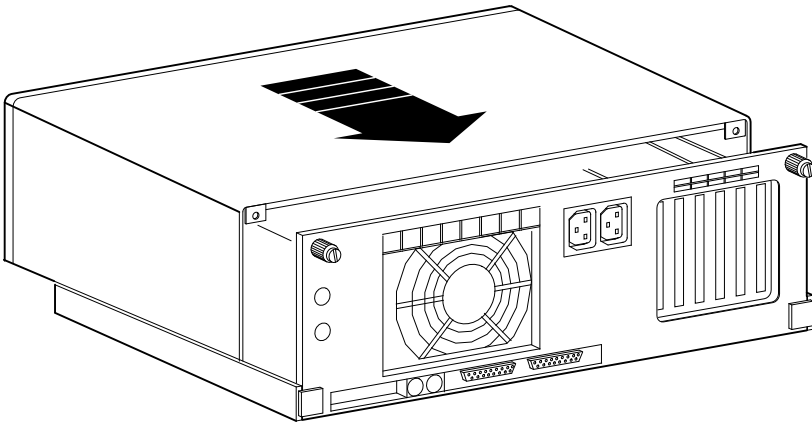

LJ-01814-T10A

4. Reconnect all cables and connectors.
 - a. Plug the keyboard connector into the rear of the system unit.
 - b. Connect any option cables and the monitor cable to the rear of the system unit.
 - c. Connect the power cord to the rear of the system unit, then plug the other end into the wall socket.

Connecting to an Ethernet Network

Figure 2-5 shows how to connect the following three types of Ethernet cables to the connectors on the *Turbo* boards:

- The *Turbo* board connected to ThinWire.
- The *Turbo TP* board connected to twisted-pair.
- The *Turbo PLUS* board connected to AUI thick wire (use cable PN BNE4G-xx where xx means cable length in meters).

When using an AUI cable connector, be sure to tighten the two screws on the connector to lock the connector in place.

Figure 2-5 Connecting to ThinWire, Twisted-Pair, and ThickWire Ethernet

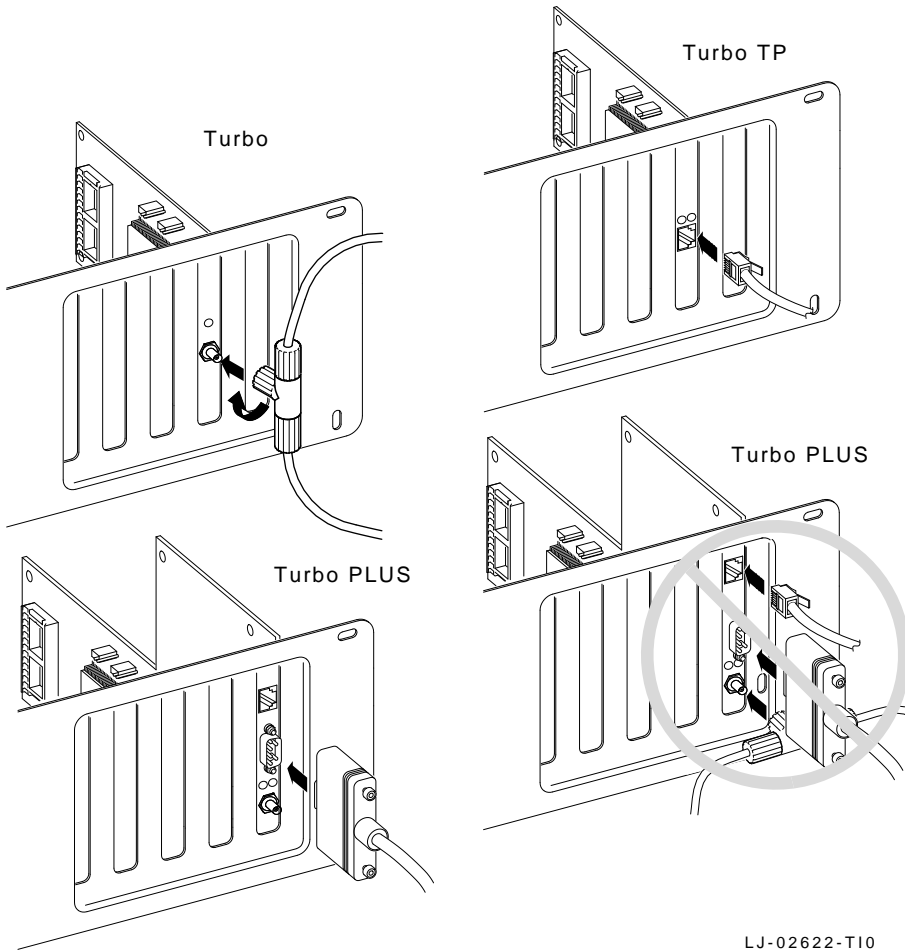

Selecting the ThinWire and Thick Wire Network Interface

The *Turbo* board has a *shunt connector* (J3) that selects the ThinWire or thick-wire network interface. The shunt connector has a 3-row jumper arrangement. The default setting of the shunt connector automatically selects either ThinWire or twisted-pair interface. If AUI connectivity is needed, the shunt connector settings need to be changed.

Table 2–1 summarizes the shunt connector settings. Figure 3 in Product Kit Contents shows the shunt connector settings ⑥ and also the AUI thick wire and ThinWire settings that are printed on the board.

Table 2–1 Shunt Connector Settings

| If You Want To . . . | Then . . . |
|--|--|
| Connect to a ThinWire or twisted-pair Ethernet network | Leave the top row of pins on the shunt connector open (the default setting). |
| Connect to an AUI Ethernet network (thick wire) | Leave the bottom row of pins on the shunt connector open. |

Caution

Static electricity can damage printed circuit boards and chips. It is strongly recommended that a grounded wrist strap and grounded work-surface-to-earth ground be used when handling these components.

Resolving BUS Conflicts on ISA and EISA Systems

Once you have installed the *Turbo* board, you are ready to turn on the system and begin the setup and software device driver installation.

The *Turbo* board is shipped with the following pre-programmed factory-default settings:

- Memory address: D0000h - D07FFh (2-KB mode)
- I/O Base address: 300h
- Interrupt value: 5

If a setting conflicts with a resource in the system, the system may not operate correctly. If this occurs, you may need to use jumpers to cover either the W1 and/or W2 posts to override the factory default settings. (This is called a "hardstrap override.")

Table 2-2 lists the available jumper selections. Figure 2-6 shows the factory-default (Out position) default jumper settings ❶ for W1 and W2 on the *Turbo*, *Turbo TP*, and *Turbo PLUS* boards.

Note

If a hardstrap override does not resolve the system conflict, contact your local Digital Service Representative.

Table 2-2 Hardstrap Override for the *Turbo*, *Turbo TP*, and *Turbo PLUS* Boards

| Jumper | | I/O Base Address | Mode |
|--------|-----|------------------|--|
| W1 | W2 | | |
| In | In | 200h | I/O only, no memory address assigned, no IRQ assigned |
| In | Out | 280h | I/O only, no memory address assigned, no IRQ assigned |
| Out | In | EISA | I/O only, no memory address assigned, no IRQ assigned |
| Out | Out | — | User defined from the NICSETUP utility or factory defaults |

Figure 2-6 Hardstrap Jumpers

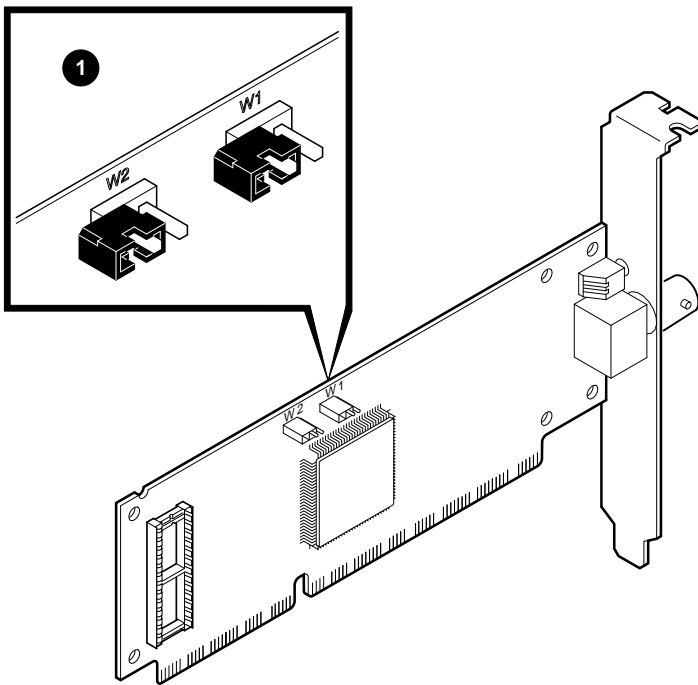

LJ-02796-T10

Once a hardstrap override resolves the system conflict, you can continue setting up the *Turbo* board, as described in Chapter 3.

To resolve bus conflicts:

1. Turn off the PC power.
2. Hardstrap the board by inserting one or both W1 and W2 jumpers on the *Turbo* board.
3. Turn on the PC power and run NICSETUP to change the board setup to resolve the conflict.
4. Select the Save Setup option to ensure that you save the setup parameters.

5. Turn off the PC power. Remove the W1 and/or W2 jumpers (see Figure 2-6).
6. Turn on the PC power. If the conflict is not resolved, repeat the procedure.

3

Configuration

This chapter explains how to run the Setup/Diagnostic utility, customize the *Turbo* board configuration, and view the board status.

Setup/Diagnostic Utility

The Digital EtherWORKS 3 *Turbo* distribution diskette contains a Setup/Diagnostic utility to help you configure the *Turbo* boards to operate without interference from other resources. It is recommended that you run the utility after initial installation to ensure that the board is set up to meet your system requirements and to verify module functionality.

The NICSETUP utility can configure and display setup options for up to four *Turbo* boards in a system. When you run NICSETUP diagnostics, make sure the RAMDIAG.COM file is in the same directory.

When the *Turbo* and *Turbo PLUS* boards are connected to ThinWire, it is necessary for the BNC T-connector to be terminated with two 50-ohm terminators; otherwise, NICSETUP will display a Loopback Error message. You will also receive Loopback Error messages if you run full diagnostics including Loopback on a *live* network.

NICSETUP will not allow diagnostics to be run when it detects that the *Turbo* board is *active*. The board is considered active if a network device driver was loaded. It may be necessary to remove the statement that loads the device driver in the CONFIG.SYS or other files, and cold boot the PC to deactivate the board.

Note

The Setup utility is based on DOS. If you are using another operating system, you need to boot your system from a DOS-based diskette and complete the Setup. Then, reboot the system to the operating system of your choice.

Accessing the Setup/Diagnostic Utility

To access the Setup/Diagnostics utility:

1. Insert the Digital EtherWORKS 3 *Turbo* distribution diskette into the disk drive.
2. Set the system to the disk drive being used.
3. Type `NICSETUP` at the DOS prompt.

An introductory window appears. Follow the instructions on each succeeding screen to set up the *Turbo* board.

Setup Conventions

The *Turbo* Setup/Diagnostic utility uses the conventions listed in Table 3-1.

Table 3-1 Setup/Diagnostic Conventions

| If you want to . . . | Then . . . |
|------------------------------------|---|
| Select an option or menu | Highlight the option or menu and press Enter. |
| Return to the previous window | Press Esc. |
| Move from one selection to another | Use the arrow keys. |

Help on any option or menu item is always available while using the Setup utility.

Default Settings

The *Turbo* board is preconfigured to work in most installations. If the default settings are appropriate for your installation, you do not need to change them. The default settings are summarized in Table 3–2.

Table 3–2 Default Settings

| Menu | <i>Turbo, Turbo TP, and Turbo PLUS</i> |
|----------------------|---|
| I/O Base | 300h |
| Memory mode | 2 KB |
| Memory base | D0000h |
| Memory address range | D0000 - D07FFh |
| IRQ Selection | IRQ5 |
| Fast bus | Disabled |
| 16-Bit bus | Enabled |

Note

If a *Turbo* board is set to use a setting that another installed board or resource uses, your computer or other boards may not operate correctly when you boot the system. If you do not know the settings for the other boards, check with your system administrator for a list of the settings.

Making Selections from the Setup Menu

The Setup menu enables you to change the settings for the following parameters:

- I/O Base—The I/O base address is the I/O address where the network interface board is located. It is important that the I/O base address does not conflict with other devices on the system.

The default address range is 300h-31fh. If this does not work, you have to hardstrap the *Turbo* board. If you need to select a different I/O address range, refer to the Resolving BUS Conflicts on ISA and EISA Systems section in Chapter 2 before running the NICSETUP utility.

- Memory mode — The memory mode is the amount of actual memory utilized and owned by the NIC card. There are three selections:

- 2 KB
 - 32 KB
 - 64 KB

In most cases, it is recommended that the 2-KB mode be used leaving a maximum amount of high memory for other application programs.

- Memory base — The memory base address is the given memory address where the network interface board is located.

Only one device can use a given memory address range. Check the documentation supplied with your PC and other installed products to determine memory address requirements and availability.

If other products use a memory range that conflicts with the *Turbo* board, select a range that is not used. Depending upon the memory mode selected, the *Turbo* board can be in any unused high memory area.

Note

Selecting a memory mode address in the A0000 to C7FFF range may cause a conflict with some system video adapters. Likewise, selecting a memory mode address in the F0000 to FFFFF range may cause a conflict with the system area of some PCs. In both cases, it is recommended that you select an address in the C8000 to EFFF range.

- **IRQ (Interrupt Request line)** — The IRQ value is the specific line that the network interface board uses to interrupt the CPU.
It is important that this line not be used by any other device in the system. Each device requires its own unique interrupt line. The default interrupt line is set to IRQ5. Other possible settings are IRQ10, IRQ11, or IRQ15.
- **Fast_Bus**—If the bus clock speed is greater than the standard 8.33 MHz, then enable the Fast_Bus parameter from the NICSETUP Custom Configuration menu. Fast_Bus does not yield any performance improvements, but allows the *Turbo* board to interoperate with a system with a fast bus. A typical fast bus speed is 10 MHz.
- **16-Bit transfers**—Tells the *Turbo* board that 16-bit memory transfers should be used. The 16-Bit transfer is the default mode and allows for best performance.

Note

If either the memory base address, I/O base address, and IRQ values are changed while executing the NICSETUP utility, you must also edit the appropriate configuration file (NET.CFG for NetWare ODI client; PROTOCOL.INI for NDIS client) using a standard text editor (such as EDIT or EDLIN) to reflect the change.

EISA Configuration

When the *Turbo* board is used as an EISA device in an EISA system, the boards' EISA configuration files are used in conjunction with your system EISA Configuration Utility (ECU) to configure the board.

The following EISA configuration files are located in the \EISA directory on the *Turbo* distribution diskette:

- !DEC2030.CFG for use with the DE203-AA or -AB *Turbo* board
- !DEC2040.CFG for use with the DE204-AB (only) *Turbo* board
- !DEC2050.CFG for use with the DE205-AA or -AB *Turbo* board

EISA Mode Setup

This section describes how to set up your *Turbo* board configuration prior to running your system ECU software.

To set up the *Turbo* board for EISA mode, perform the following procedure:

1. Install the *Turbo* board in an EISA system.
2. Insert the *Turbo* distribution diskette into the PC disk drive and set the default directory to the drive being used (for example, drive A).
3. Type NICSETUP at the DOS system prompt, then follow the screen instructions to display the Main Menu.
4. Select the Setup option, then press Enter twice to display the User Selected Value screen. The I/O base address (for example, 300H) is highlighted. Press Enter again to display a list of the system I/O addresses.
5. Use the down-arrow key to scroll to the EISA mode option (bottom of list), then press Enter. Note that the I/O base now reads I/O Base = EISA.

Note

The EISA I/O base will only appear if the system you are using is an EISA PC.

6. Change any other settings (for example, Memory Mode, Memory Base address, IRQ, etc.) that are required by your PC operating environment.
7. Select the Save Setup Data option to save your changes, then press Enter. Press Enter again to write the data.
8. Press Esc twice to exit NICSETUP and return to the DOS prompt.
9. Turn the system power off and then on again. The changes you make in NICSETUP take effect only after a cold boot.

You can now run the system ECU to add your *Turbo* board to the EISA system configuration. Refer to your PC documentation for information on how to install a board using your system ECU.

If the board fails diagnostics with an FF error, it is because the correct !DEC20x0.CFG file was not used to configure the *Turbo* board.

Note

It is *not* necessary to hardstrap the *Turbo* board for EISA mode operation. Hardstrapping the board for that setting will prevent the ECU from finding the board and cause a slot error message.

Hardstrapping the board to EISA mode is needed only when a configured board causes a conflict and the PC is inoperable. The hardstrapping will allow the board to be reconfigured to correct the conflict.

Custom Configuration

The *Turbo* NICSETUP utility Custom Configuration menu allows you to select certain operational parameters that are unique to the module that the Setup utility is run against. These parameters are listed in Table 3–3.

Table 3–3 Custom Parameters

| Custom Parameter | Function | Default |
|----------------------------------|---|------------|
| Less aggressive backoff (LAB) | When enabled, the backoff slot timer stops counting when there is activity on the network. This helps smooth out network congestion on a busy network, but may in turn slightly degrade the network throughput of this station. | Disabled |
| Signal quality error check (SQE) | When enabled, transmissions are expected to be followed by an SQE (heartbeat) signal. This is a network management feature. | Enabled |
| Remote boot timeout ¹ | Controls the time-out period for attempting a remote boot operation. | 30 seconds |
| Remote boot enable ¹ | Determines whether the remote boot feature is enabled or disabled. | Disabled |

¹This feature requires that an optional remote boot ROM chip be installed.

To change the configuration parameters:

1. Select the Custom Configuration menu.

The NICSETUP utility displays the parameters for up to four boards and highlights the Current Configuration dialog box, displaying the customized parameters for the selected board.

2. If you need to change the parameters for a different board, use the arrow keys to move to the board number you want to configure, and then press Enter. The selected board is highlighted.
 3. The *Turbo* NICSETUP utility displays the User Selected Configuration dialog box, which lists all the parameters that are user-definable for the selected board. It also lists two options for writing the new parameters to *Turbo* memory:
 - Write configuration data
 - Write default configuration data
 4. Change the parameters using one of the following:
 - If you wish to change all parameters to the default, select Write Default Configuration Data and press Enter.
The default values are reflected in the User Selected Configuration dialog box by an asterisk (*).
A confirmation window appears. Press Enter to confirm that you wish to change all the parameters to the default settings.
 - If you need to change one or more of the parameters from the current settings, use the arrow key to highlight the parameter and press Enter.
The NICSETUP utility lists all the acceptable settings for the selected parameter.
To change the parameter, use the arrow keys to highlight the appropriate parameter and press Enter.
The new value appears in the User Selected Configuration dialog box.
- To write the new parameters to memory, select Write Configuration Data.
5. Exit the NICSETUP utility and turn off power to the PC. The new configuration data takes effect the next time the system is turned on. If the PC does not operate correctly, you may have set one of the *Turbo* board parameters to the same setting as another module or system resource. Refer to the Resolving BUS Conflicts on ISA and EISA Systems section for more information.

Module Status

When you select the Module Status menu option, a listing of all the parameters for the selected module is provided.

To view the status of a module:

1. Select the Module Status option from the Main menu.
The NICSETUP utility highlights the settings for the first board.
2. To change boards, select the board and press Enter.

Exiting NICSETUP

To exit NICSETUP, select the Exit option from the Main menu.

The following warning message appears:

Do you really want to quit? (Y/N)

Press Y to exit NICSETUP, or press any other key to return to the Main window.

Note

If you do not Write Configuration Data or Write Default Data, no information is updated to the *Turbo* board when you exit NICSETUP.

Once you have completed the NICSETUP utility procedure and modified, if necessary, a configuration file (see Chapter 4), you must reboot the system for any changes that were made to take effect.

4

Software Device Driver Installation

This chapter explains how to install the Digital EtherWORKS 3 *Turbo* (EWRK3) software device driver files required for PATHWORKS, LAN Manager-based, and NetWare network operating systems. These files (NDIS and ODI) are contained on the EWRK3 distribution diskette.

The NICSETUP.EXE diagnostic utility will execute automatically during device driver installation. Refer to Appendix A if any problems occur during the installation. Refer to the ERROR.TXT file in the top-level directory of the distribution diskette for a description of the error messages and the suggested corrective action. If the error cannot be corrected, contact your local Digital service representative for further assistance.

If you do not wish to execute the diagnostics each time the driver is loaded, edit the PROTOCOL.INI file to read Diagnostic = 0.

Figure 4–1 provides the format and contents on the distribution media.

Figure 4-1 Distribution Media (Format and Contents)

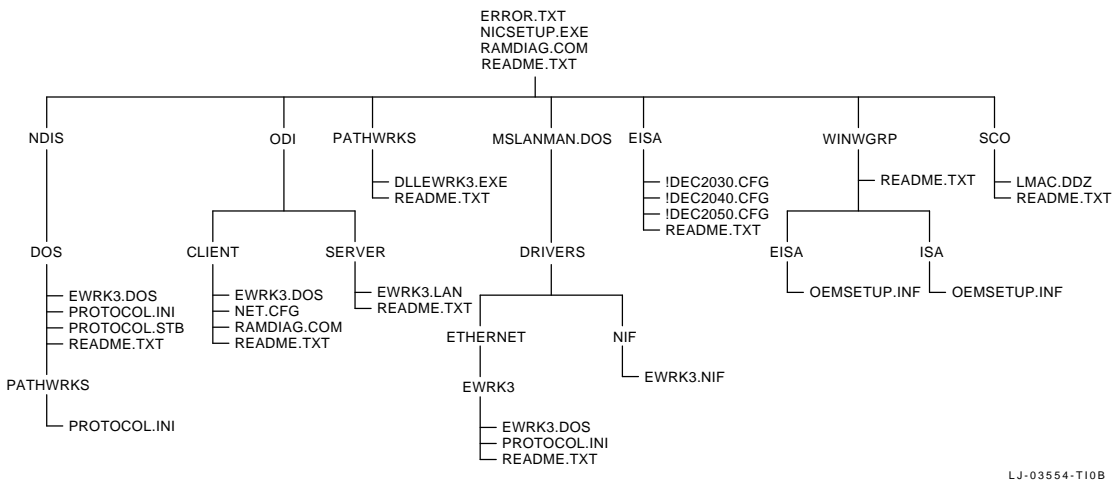

NDIS-DOS Device Driver Installation

Use the following procedures to install the NDIS driver in either a PATHWORKS or non-PATHWORKS environment. To change or view the *Turbo* board settings (for example, Memory range, I/O range, or IRQ line) required by your PC operating environment, run the NICSETUP utility prior to the board installation.

- To install the NDIS-DOS device driver in a PATHWORKS environment:
 1. Insert the distribution diskette into the disk drive (for example, drive A) and run NETSETUP to automate the network installation procedure.

2. When prompted for the network adapter type, select the Other NDIS option.

Note

PATHWORKS, version 5.0 or greater, includes a menu option to allow selection of the EtherWORKS 3 *Turbo* board in NETSETUP. For those versions, the selection of Other NDIS is inappropriate.

3. When prompted for the full pathname of the NDIS driver, enter the following:

```
A:\NDIS\DOS\EWRK3.DOS
```

4. When prompted for the full pathname of the PROTOCOL.INI stub file, enter the following:

```
A:\NDIS\DOS\PATHWRKS
```

NETSETUP will display the configuration parameters read from the PROTOCOL.INI file. Make sure the parameters match those of the *Turbo* board configuration. By default, the parameters will match those of the *Turbo* board unless you changed a setting in NICSETUP.

5. The EtherWORKS 3 NDIS driver installation is complete. Reboot the system.

NETSETUP will update your CONFIG.SYS, AUTOEXEC.BAT, PROTOCOL.INI, and network-specific files automatically.

- To install the NDIS-DOS device driver in a non-PATHWORKS environment:
 1. Insert the distribution diskette into the disk drive (for example, drive A) and copy the following file to your network directory:

```
COPY A:\NDIS\DOS\EWRK3.DOS
```

2. When prompted for the network adapter type, select the Other NDIS option.

Note

PATHWORKS, version 5.0 or greater, includes a menu option to allow selection of the EtherWORKS 3 *Turbo* board in NETSETUP. For those versions, the selection of Other NDIS is inappropriate.

3. When prompted for the full pathname of the NDIS driver, enter the following:

```
A:\NDIS\DOS\EWRK3.DOS
```

4. When prompted for the full pathname of the PROTOCOL.INI stub file, enter the following:

```
A:\NDIS\DOS\PATHWRKS
```

5. If the CONFIG.SYS file is not updated automatically, edit the file to install the PROTMAN.SYS and EWRK3.DOS device drivers as follows:

```
DEVICE=C:\PROTMAN.SYS  
DEVICE=C:\EWRK3.DOS
```

6. The EtherWORKS 3 NDIS driver installation is complete. Reboot the system.

Using Extended Memory Manager

If you use a memory manager such as EMM386 or QEMM in either a PATHWORKS or non-PATHWORKS environment, you must exclude the memory space that the *Turbo* board is using to prevent it from being mapped as high memory. The following is an example of the text to add to your CONFIG.SYS file if you use a memory manager:

```
DEVICE=C:\DOS\EMM386.EXE x=D000-D07F frame=E000
```

This line is used to exclude the default memory space of the *Turbo* board at D0000 to D07FF in 2K mode. If the board is configured for 32K mode at the same memory base address, add the following text to your CONFIG.SYS file:

```
DEVICE=C:\DOS\EMM386.EXE x=D000-D77F frame=E000
```

Consult your memory manager documentation for further information.

Note

If you receive an error message during diagnostics such as Memory Queue Test Failed, ensure that your extended memory manager has excluded the EtherWORKS 3 *Turbo* board memory region in the CONFIG.SYS file.

ODI Client Device Driver Installation

The EWRK3.COM device driver file is used in conjunction with the LSL.COM, IPXODI.COM, and NETX.COM files that are provided on the NetWare DOS/ODI service diskette.

If this is a first-time installation, check with your NetWare system manager to ensure that your PC has been properly configured as a NetWare client.

To install the ODI client device driver:

1. Create a subdirectory from which to execute the client driver. Copy the files located in the directory A:\ODI\CLIENT from the EWRK3 distribution diskette into this subdirectory and set the default to this directory. (The following assumes the root directory of the C:\> disk drive is being used.)

```
C:\> MD NETWARE
C:\> CD NETWARE
```

2. Copy the necessary files from the EWRK3 distribution diskette to the login directory:

```
C:\NETWARE> COPY A:\ODI\CLIENT\*.*
```

3. The EWRK3 ODI driver installation is complete. Reboot the system.

ODI Server Device Driver Installation

To install the ODI server device driver:

1. On the server, change your current directory to where the file `SERVER.EXE` resides. (NetWare is used as an example.)

```
C:\> CD NETWARE
```

2. Copy the necessary files from the distribution diskette into this directory.

```
C:\NETWARE> COPY A:\ODI\SERVER\*.*
```

3. Access the NetWARE server software.

```
C:\NETWARE> SERVER
```

4. At the prompt (:), install the device driver.

```
LOAD C:\NETWARE\EWRK3
```

5. After answering the configuration questions, bind the driver to the protocol stack. (IPX is used in this example.)

```
BIND IPX EWRK3  
Network Number: <Your choice>
```

Note

When answering the configuration questions, your responses must match the settings selected during the NICSETUP process.

PATHWORKS Native Datalink Installation

To install the DLLEWRK3.EXE file, use the following procedure:

1. Enter NICSETUP to change the *Turbo* board configuration from 2K mode (the default) to 32K or 64K mode.
2. If you are using an Extended Memory Manager, ensure that the board memory range is excluded (for example, x=D000-D7FF).
3. For users of PATHWORKS version 4.1 or earlier, run NETSETUP to automate the Native Datalink driver installation. Select the EtherWORKS Native Datalink as the Ethernet adapter type.
4. After NETSETUP completes, change the %BOOT%\dlldepca.exe line in STARTNET.BAT to %BOOT%\decnet\dllewrk3.exe.
5. Once this change is complete, copy the DLLEWRK3.EXE driver from the distribution diskette \PATHWRKS directory to the \DECNET directory on your hard drive.
6. For users of PATHWORKS version 5.0 or later, select the EtherWORKS 3 Native Datalink menu option during NETSETUP to automate the installation.

Note

Unlike the Native Datalink driver for earlier EtherWORKS products, DLLEWRK3 does not require changing the command line. If you need to alter the *Turbo* board configuration parameters, execute the NICSETUP utility included on the board distribution diskette. When the DLLEWRK3 driver is invoked, it will automatically read the board's internal settings.

A

Problem Solving

This appendix describes problems you could encounter with the Digital EtherWORKS 3 *Turbo* board and suggests possible causes and solutions.

The *Turbo* board diagnostics are normally executed prior to the driver being loaded to ensure the hardware is functional before connecting to the network. If any of the diagnostic tests fail, the driver will not load and the network connection cannot be made. A diagnostic failure may be the result of an incorrect software or hardware installation, a resource conflict, or a defective board.

Isolating Faults

Table A-1 describes how to isolate faults by the symptoms that are occurring.

Table A-1 Fault Isolation By Symptom

| Symptom | Possible Cause | Recommended Action |
|---|--|--|
| The system is on, but there is no display. | The monitor is not on or it is not connected to the video board. | Be sure the monitor cable is firmly connected to the video board. Set the monitor power switch to ON. |
| | The <i>Turbo</i> board is not seated firmly. | Turn off power to the computer. Remove and reinsert the board firmly into the option slot (Figure 2-3). |
| | The <i>Turbo</i> board is conflicting with another device. | See the Resolving BUS Conflicts on ISA and EISA Systems section in Chapter 2. |
| The system is on, but nothing happens. The amber LED is on for longer than 30 seconds. The keyboard does not respond. | The <i>Turbo</i> board is preventing the CPU from operating correctly. | Turn the computer power off and reseat the board. Disconnect the ThinWire cable from the <i>Turbo</i> board, then turn the computer power back on. |

(continued on next page)

Table A-1 (Cont.) Fault Isolation By Symptom

| Symptom | Possible Cause | Recommended Action |
|----------------------------------|---|--|
| The system does not remote boot. | The memory address, I/O address, or IRQ setting is incorrect or is causing a conflict with another board. | Check the setup values and reset if necessary. A conflict could exist between the <i>Turbo</i> board and another installed board. See the Resolving BUS Conflicts on ISA and EISA Systems section in Chapter 2. If the problem persists, contact your system administrator or authorized service representative. |
| | The software driver is not being installed properly. | Check that the <i>Turbo</i> board setup agrees with the software installation settings. Check that the software installation syntax is correct in CONFIG.SYS, AUTOEXEC.BAT, or another system file. |
| | The <i>Turbo</i> board is not configured for remote boot. | Run NICSETUP and ensure that the remote boot feature is enabled in the Custom Configuration Menu. |
| | The default remote boot time out could be insufficient for a busy network. | Run NICSETUP and change the remote boot timeout period to 2.5 minutes. |

(continued on next page)

Table A-1 (Cont.) Fault Isolation By Symptom

| Symptom | Possible Cause | Recommended Action |
|---|---|--|
| | The Ethernet address is not registered with the remote boot server. | Register the <i>Turbo</i> board with the server. If the problem persists, contact your system administrator. |
| | The remote boot ROM chip is not present or is incorrectly installed. | Check the ROM chip installation to ensure the chip is seated firmly and there are no bent pins. |
| | The ThinWire link is not connected correctly. | Check to see if the coaxial cable is connected and terminated correctly at each end. |
| | The twisted-pair (TP) link is down, signaled by the green LED being off on the <i>Turbo TP/Turbo PLUS</i> board. | Verify that the twisted-pair cable is connected and correctly attached to the HUB. A straight-through or cross-over type of cable may be required. |
| The system is on, but the network does not start. The LED is off. | The network cables are loose or terminated incorrectly. | Secure all cables and terminations. |
| | <p>A conflict exists with another board in the system:</p> <ul style="list-style-type: none"> • The IRQ settings are incorrect. • The I/O address or the memory address range is incorrect. | <p>Check the setup values and reset if necessary.</p> <p>Check the setup values and reset if necessary.</p> |

(continued on next page)

Table A-1 (Cont.) Fault Isolation By Symptom

| Symptom | Possible Cause | Recommended Action |
|---|---|--|
| | The Ethernet address is not registered for this address node. | Register the <i>Turbo</i> board with the remote boot server. If the problem persists, contact your system administrator. |
| The system is on and displays Digital EtherWORKS 3 and a self-test error message during system startup. | A possible problem exists with the <i>Turbo</i> board or the software is not installed correctly. | Refer to the <i>Turbo</i> board distribution diskette file A:\Error.txt for more information and troubleshooting tips regarding the diagnostic error message. Replace or reinsert the <i>Turbo</i> board and try starting the system again. |

Error Messages

Table A-2 describes possible EtherWORKS 3 *Turbo* board error messages and the recommended corrective actions for each group of messages.

Table A-2 Error Messages

| Message | Recommended Actions |
|--|--|
| Unable to determine I/O address Ethernet Address ROM CRC failed Wrong Card ID Register R/W test failed EEPROM Checksum test failed | <p>Ensure network configuration file settings (PROTOCOL.INI for NDIS users, NET.CFG for ODI users) match the settings of the <i>Turbo</i> board.</p> <p>Ensure there is no I/O conflict (that occurs when two boards live in the same I/O space). Try to hardstrap the board and use NICSETUP to program the board to live in another I/O space. Refer to the README file for details about how to hardstrap the board.</p> <p>Refer to the <i>Turbo</i> board distribution diskette file A:\Error.txt for more information and troubleshooting tips regarding the diagnostic error message.</p> <p>If neither corrective action works, you may have a defective board. Contact your Digital Sales Representative.</p> |

(continued on next page)

Table A-2 (Cont.) Error Messages

| Message | Recommended Actions |
|---|---|
| IRQ test failed ICR, Interrupt Enable test failed ICR (TNE, RNE, TXD, or RXD) Mask test failed | Ensure network configuration file settings match settings of <i>Turbo</i> board. Use NICSETUP to view the board settings. Refer to the <i>Turbo</i> board distribution diskette file A:\Error.txt for more information and troubleshooting tips regarding the diagnostic error message. Ensure there is no IRQ conflict (that occurs when two devices want to use the same interrupt line). Try to hardstrap the board and use NICSETUP to program the board to use another IRQ line. |

(continued on next page)

Table A–2 (Cont.) Error Messages

| Message | Recommended Actions |
|---|---|
| Memory Address test failed Memory Knaizuk test failed Memory Bitwalk test failed Queue, Free Memory Queue test failed | Ensure network configuration file settings match the settings of the <i>Turbo</i> board. Use NICSETUP to view the board settings. |
| Queue, Receive Queue test failed Queue, Transmit Queue test failed Queue, Transmit Done Queue test failed Queue, Page Index Register test failed | Refer to the <i>Turbo</i> board distribution diskette file A:\Error.txt for more information and troubleshooting tips regarding the diagnostic error message. |
| Queue, I/O Page Register test failed Queue, Memory Page Register test failed | Ensure there is no memory conflict (that occurs when two boards or software want to live in the same memory space). Try to hardstrap the board and use NICSETUP to program the board to live in another memory space. |

(continued on next page)

Table A-2 (Cont.) Error Messages

| Message | Recommended Actions |
|--|---|
| Xmit Status, Xmit Valid bit not set Xmit Status, SQE check failed Xmit Status, ECL failed Xmit Status, LCL failed Xmit Status, ID failed Xmit Status, NCL failed | Refer to the <i>Turbo</i> board distribution diskette file A:\Error.txt for more information and troubleshooting tips regarding the diagnostic error message. |
| Recv Status, IAM failed Recv Status, MCM failed Recv Status, PLL failed Recv Status, CRC failed Xmit Control, STOP test failed Xmit Control, Q-Mode test failed Xmit Control, PAD test failed Xmit Control, IFC test failed Xmit Control, ISA test failed CSR, Runt Accept test failed CSR, Promiscuous Mode Enable test failed CSR, Multicast Enable test failed CSR, Transmit Not Empty bit failed CSR, Receive Not Empty bit failed CSR, Transmit Disable test failed CSR, Receive Disable test failed Transmit Packet Size over 1514 Receive Packet Size over 1514 Transmit Packet Size is zero Receive Packet Size is zero Transmit Failure Receive Failure Transmit Timeout Receive Timeout | These errors are network-related test failures. If your network driver was installed before running the diagnostics, power down the PC and start again. If the error messages persist, board may be defective. Contact your Digital Sales Representative. |

(continued on next page)

Table A-2 (Cont.) Error Messages

| Message | Recommended Actions |
|---|--|
| CR, Loopback test failed CR, Full Duplex test failed | <p data-bbox="532 840 951 945">Refer to the <i>Turbo</i> board distribution diskette file A:\Error.txt for more information and troubleshooting tips regarding the error message.</p> <p data-bbox="532 972 935 1155">These errors are supplemental network tests that require loopback connectors for ThinWire or a TP repeater link for TP testing. These tests are only available when diagnostics are run from the NICSETUP Diagnostic menu.</p> <p data-bbox="532 1182 932 1392">To test the ThinWire coaxial port (when present), the board must be removed from the live network and the ThinWire connector properly terminated with a T-connector and two terminators. Without proper termination the Loopback or Full Duplex test will fail.</p> <p data-bbox="532 1419 959 1602">To test the TP port (when present), the board must have a valid link to a TP repeater. The board that supports TP has a green LED that lights when the link to the TP repeater is good. If the green LED does not light, check TP cabling and TP repeater port.</p> <p data-bbox="532 1629 959 1787">To test the AUI thick wire port, select AUI port using board shunt jumper and connect to AUI repeater. If the error message persists, board may be defective. Contact your Digital Sales Representative.</p> |

B

General Information

This appendix provides some general system specification and cabling requirements for the Digital EtherWORKS 3 *Turbo* board.

Functional Components

The major functional components on the *Turbo* board include the following:

- Digital EtherWORKS 3 *Turbo* bus interface and support registers
- Ethernet network protocol controller (MAC)
- Ethernet media transceiver
- 128 KB Network buffer RAM
- 32 KB Diagnostics and network remote boot firmware ROM (optional)
- Unique Ethernet address ROM
- Non-volatile electrically erasable memory

LEDs

Table B-1 LED Activity

| Board | Number of LEDs | Function | LED Color |
|----------------------------|----------------|----------------------|-----------|
| <i>Turbo/Turbo PLUS</i> | 1 | Self-test or traffic | Amber |
| <i>Turbo TP/Turbo PLUS</i> | 2 | Self-test or traffic | Amber |
| | | TP Link | Green |

System Specifications

This section lists the system specifications for the Digital EtherWORKS 3 *Turbo* board.

- Memory modes
- Memory mode addresses
- I/O base addresses
- IRQ lines
- Power requirements
- PC operating Environment

Note

Default settings are signified by an asterisk (*).

Memory Modes

The memory modes for the Digital EtherWORKS 3 *Turbo* boards include the following:

- 2 KB*
- 32 KB
- 64 KB

Memory Mode Addresses

Selecting a memory mode address in the A0000 to C7FFF range may cause a conflict with some system video adapters. Likewise, selecting a memory mode address in the F0000 to FFFFF range may cause a conflict with the system area of some PCs. In both cases, it is recommended that you select an address in the C8000 to EFFF range.)

The memory mode addresses for the Digital EtherWORKS 3 *Turbo* boards are listed in Table B-2.

Table B–2 Memory Mode Addresses

| Memory Buffer Size | Memory Address Range |
|--------------------|---|
| 64 KB | A0000-AFFFF, B0000-BFFFF, C0000-CFFFF, D0000-DFFFF, E0000-EFFFF, F0000-FFFFF |
| 32 KB | A0000 - A7FFF, A8000 - AFFFF, B0000 - B7FFF, B8000 - BFFFF, C0000 - C7FFF, C8000 - CFFFF, D0000 - D7FFF, D8000 - DFFFF, E0000 - E7FFF, E8000 - EFFFF, F0000 - F7FFF, F8000 - FFFFF |
| 2 KB ¹ | A0000 - A07FF, A0800 - A0FFF, A1000 - A17FF, A1800 - A1FFF, A2000 - A27FF, A2800 - A2FFF, A3000 - A37FF, A3800 - A3FFF,... B0000 - B07FF, B0800 - B0FFF, B1000 - B17FF, B1800 - B1FFF, B2000 - B27FF, B2800 - B2FFF, B3000 - B37FF, B3800 - B3FFF,... C0000 - C07FF, C0800 - C0FFF, C1000 - C17FF, C1800 - C1FFF, C2000 - C27FF, C2800 - C2FFF, C3000 - C37FF, C3800 - C3FFF,... D0000 - D07FF, D0800 - D0FFF, D1000 - D17FF, D1800 - D1FFF, D2000 - D27FF, D2800 - D2FFF, D3000 - D37FF, D3800 - D3FFF,... E0000 - E07FF, E0800 - E0FFF, E1000 - E17FF, E1800 - E1FFF, E2000 - E27FF, E2800 - E2FFF, E3000 - E37FF, E3800 - E3FFF,... F0000 - F07FF, F0800 - F0FFF, F1000 - F17FF, F1800 - F1FFF, F2000 - F27FF, F2800 - F2FFF, F3000 - F37FF, F3800 - FFFFF,... |

¹Each address range increases by 800 Hex. Any 2-KB boundary in the listed segments can be used. Not all address ranges are listed.

I/O Base Addresses for the *Turbo* Boards

The I/O base addresses for the Digital EtherWORKS 3 *Turbo* boards are as follows. Each I/O address range takes up 1fh location.

| | | |
|------|------|-------------------|
| 100H | 200H | 300H ¹ |
| 120H | 220H | 320H |
| 140H | 240H | 340H |
| 160H | 260H | 360H |
| 180H | 280H | 380H |
| A0H | 2A0H | 3A0H |
| 1C0H | 2C0H | 3C0H |
| 1E0H | 2E0H | 3E0H |
| | | EISA ¹ |

¹EISA mode is a slot dependent I/O address range.

IRQ Values

The IRQ values for the Digital EtherWORKS 3 *Turbo* boards include the following.

- 5*
- 10
- 11
- 15

Power Requirements

Table B–3 lists the electrical parameters for the Digital EtherWORKS 3 *Turbo* boards.

Table B–3 Electrical Parameters

| Board | Power (Maximum) | DC Amps (+5.0 V) (Maximum) | DC Amps (+12.0 V) (Maximum) | Bus Loads |
|-------------------|-----------------|----------------------------|-----------------------------|-----------|
| <i>Turbo</i> | 6.1 W | 0.5 A | 0.30 A | 1 CMOS |
| <i>Turbo TP</i> | 3.5 W | 0.7 A | 0.00 A | 1 CMOS |
| <i>Turbo PLUS</i> | – | – | – | – |
| ThinWire or TP | 7.1 W | 0.7 A | 0.30 A | 1 CMOS |
| Thick Wire | 9.5 W | 0.7 A | 0.5 A | 1 CMOS |

PC Operating Environment

The operating environment for the Digital EtherWORKS 3 *Turbo* boards is as follows.

- Temperature (at sea level): 10°C to 40°C (50°F to 104°F)
- Relative humidity: 10% to 90% (noncondensing)
- Radiated emissions: FCC Class B, VDE Class B

Caution

When adding any boards to your computer, verify that the combined power (wattage) required for all boards in your computer does not exceed the power supply rating. Check your PC documentation for this information.

Obtaining EtherWORKS Driver Files

To obtain EtherWORKS software driver files on the Internet:

1. Perform an ftp connect to gatekeeper.dec.com using the password anonymous.
2. Enter a Logon ID of your choice.
3. Enter the following command, in lowercase letters, to change your directory:

```
cd/pub/micro/msdos/network
```

4. Select the image mode ftp> i.
5. Enter the command ftp> get on the ethwrks3.zip file (which contains all the driver files).
6. Enter the command ftp> get on the etherworks3.dd.Z file (which contains the SCO/UNIX driver files).

To obtain EtherWORKS software driver files from CompuServe:

1. Select the DECPCI (GO DECPCI) conference to enter the LAN Controllers library.
2. Retrieve the latest version of the ethwrks3.zip file.

For information on how to obtain a CompuServe account, call (800)848-8990.

